



BY APPOINTMENT TO
HER MAJESTY QUEEN ELIZABETH II
MANUFACTURERS OF DAIMLER AND JAGUAR CARS
JAGUAR CARS LIMITED COVENTRY



BY APPOINTMENT TO
HER MAJESTY QUEEN ELIZABETH
THE QUEEN MOTHER
MANUFACTURERS OF DAIMLER AND JAGUAR CARS
JAGUAR CARS LIMITED COVENTRY



BY APPOINTMENT TO
HIS ROYAL HIGHNESS THE PRINCE OF WALES
MANUFACTURERS OF DAIMLER AND JAGUAR CARS
JAGUAR CARS LIMITED COVENTRY

X-TYPE

2.0L/2.5L/3.0L Electrical Guide

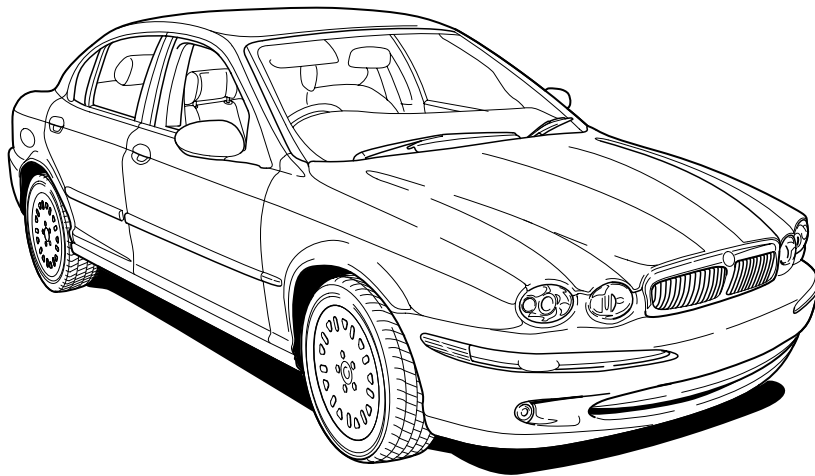

2.5L & 3.0L – 2001.5 Model Year;
2.0L – 2002.25 Model Year

Published by Parts and Service Communications
Jaguar Cars Limited

Publication Part Number – JJM 10 38 20 / 22





Table of Contents: Figures 2 – 3

Abbreviations and Acronyms 4

Introduction 5

Component Index 6 – 9

User Instructions 10 – 11

Symbols and Codes 12 – 14

Network Configuration 15

Relay and Fuse Location 16

Fuse Box Connectors 17

Main Power Distribution 18

Harness Layout 19

Ground Point Location 20

Control Module Location 21

Control Module Pin Identification 22 – 27

Electrical Guide Figures and Data follows after page 27
(pages are numbered by Figure number)

Appendix (CAN and SCP Messages) follows Figures and Data



FIGURES

Fig.	Description	Variant
01 Power Distribution		
Fig. 01.1	Main Power Distribution	All Vehicles
Fig. 01.2	Battery Power Distribution	All Vehicles
Fig. 01.3	Ignition Switched Power Distribution: I (Accessory)	All Vehicles
Fig. 01.4	Ignition Switched Power Distribution: II (Run)	All Vehicles
Fig. 01.5	Ignition Switched Power Distribution: Battery Saver	All Vehicles
Fig. 01.6	Engine Management System Switched Power Distribution	All Vehicles
02 Battery; Starter; Generator		
Fig. 02.1	Battery; Starter; Generator: 2.5L & 3.0L	2.5L & 3.0L Vehicles
Fig. 02.2	Battery; Starter; Generator: 2.0L	2.0L Vehicles
03 Engine Management		
Fig. 03.1	Engine Management: 2.5L & 3.0L – Part 1	2.5L & 3.0L Vehicles
Fig. 03.2	Engine Management: 2.5L & 3.0L – Part 2	2.5L & 3.0L Vehicles
Fig. 03.3	Engine Management: 2.0L – Part 1	2.0L Vehicles
Fig. 03.4	Engine Management: 2.0L – Part 2	2.0L Vehicles
04 Transmission		
Fig. 04.1	Automatic and Manual Transmissions: Early Production	2.5L & 3.0L Vehicles
Fig. 04.2	Automatic and Manual Transmissions: Later Production	All Vehicles (Later Production)
Fig. 04.3	Automatic and Manual Transmissions: Later Production VIN D15361 →	All Vehicles (Later Production)
05 Chassis		
Fig. 05.1	Anti-Lock Braking	2.5L & 3.0L ABS Vehicles
Fig. 05.2	Dynamic Stability Control	DSC Vehicles
Fig. 05.3	Anti-Lock Braking / Traction Control	2.0L ABS/TC Vehicles
06 Climate Control		
Fig. 06.1	Manual Climate Control System; Glass Heaters	Manual Climate Control Vehicles
Fig. 06.2	Automatic Climate Control System; Glass Heaters	Automatic Climate Control Vehicles
07 Instrumentation		
Fig. 07.1	Instrument Cluster	All Vehicles
Fig. 07.2	Audible Warnings	All Vehicles
08 Exterior Lighting		
Fig. 08.1	Exterior Lighting: Front – Autolamps	Autolamp Vehicles
Fig. 08.2	Exterior Lighting: Front – Non Autolamps; Exterior Lighting: Front – Daytime Running Lamps	Non Autolamp Vehicles; Daytime Running Lamp Vehicles
Fig. 08.3	Exterior Lighting: Rear	All Vehicles
Fig. 08.4	Exterior Lighting: Rear – European Trailer Towing	EUR Trailer Towing Vehicles
Fig. 08.5	Exterior Lighting: Rear – U.K. Trailer Towing	U.K. Trailer Towing Vehicles
Fig. 08.6	Exterior Lighting: Rear – NAS Trailer Towing	NAS Trailer Towing Vehicles
Fig. 08.7	Headlamp Leveling	Headlamp Leveling Vehicles
09 Interior Lighting		
Fig. 09.1	Interior Lighting	All Vehicles
Fig. 09.2	Dimmer-Controlled Lighting	All Vehicles
10 Steering; Mirrors; Heaters		
Fig. 10.1	Variable Assist Steering; Electrochromic Rear View Mirror	All Vehicles
Fig. 10.2	Door Mirrors: Movement, Fold-Back	All Vehicles



FIGURES

Fig.	Description	Variant
11 Seat Systems		
Fig. 11.1	Powered Seats: 8-Way Movement	8-Way Powered Seat Vehicles
Fig. 11.2	Powered Seats: 2-Way Movement	2-Way Powered Seat Vehicles
Fig. 11.3	Seat Heaters	Heated Seat Vehicles
12 Door Locking; Security		
Fig. 12.1	Central Door Locking: Double Locking	Double Locking Vehicles
Fig. 12.2	Central Door Locking: Non Double Locking	Non Double Locking Vehicles
Fig. 12.3	Security System	All Vehicles
13 Wash / Wipe		
Fig. 13.1	Wash / Wipe System	Non Rain Sensing Vehicles
Fig. 13.2	Wash / Wipe System with Rain Sensing	Rain Sensing Vehicles
14 Powered Windows; Sliding Roof		
Fig. 14.1	Powered Windows: LHD	LHD Vehicles
Fig. 14.2	Powered Windows: RHD	RHD Vehicles
Fig. 14.3	Sliding Roof	Sliding Roof Vehicles
15 In-Car Entertainment		
Fig. 15.1	In-Car Entertainment: Standard	Standard ICE Vehicles
Fig. 15.2	In-Car Entertainment: Premium	Premium ICE Vehicles
16 Telematics		
Fig. 16.1	Telephone System: ROW	ROW Vehicles
Fig. 16.2	Telephone System: NAS	NAS Vehicles
Fig. 16.3	Telephone System with Voice: ROW	ROW Vehicles
Fig. 16.4	Telephone System with Voice: NAS	NAS Vehicles
Fig. 16.5	Voice Control System	Voice Only Vehicles
Fig. 16.6	Navigation System (except Japan)	NAV Vehicles except Japan
Fig. 16.7	Navigation System: Japan	Japan NAV Vehicles
17 Occupant Protection		
Fig. 17.1	Advanced Restraint System	All Vehicles
18 Driver Assist		
Fig. 18.1	Parking Aid System	Parking Aid Vehicles
19 Ancillaries		
Fig. 19.1	Ancillaries: Horn, Cigar Lighter, Accessory Connectors, Garage Door Opener	All Vehicles
20 Vehicle Multiplex Systems		
Fig. 20.1	Controller Area Network	All Vehicles
Fig. 20.2	Standard Corporate Protocol Network; Serial Data Link	All Vehicles
Fig. 20.3	D2B Network: Part 1	All Vehicles
Fig. 20.4	D2B Network: Part 2	All Vehicles



The following abbreviations and acronyms are used throughout this Electrical Guide:

A/C	Air Conditioning
A/CCM	Air Conditioning Control Module
ABS	Anti-Lock Braking
ABS/TC	Anti-Lock Braking / Traction Control
APP SENSOR	Accelerator Pedal Position Sensor
APP1	Accelerator Pedal Position Sensor Element 1
APP2	Accelerator Pedal Position Sensor Element 2
AUTO	Automatic Transmission
B+	Battery Voltage
BANK 1	RH Cylinder Bank (Cylinders 1, 3, 5)
BANK 2	LH Cylinder Bank (Cylinders 2, 4, 6)
CAN	Controller Area Network
CKP SENSOR	Crankshaft Position Sensor
CM	Control Module
CMP SENSOR / 1	Camshaft Position Sensor / Bank 1
CMP SENSOR / 2	Camshaft Position Sensor / Bank 2
D2B	Fiber Optic Network
DSC	Dynamic Stability Control
ECM	Engine Control Module
ECT SENSOR	Engine Coolant Temperature Sensor
EFT SENSOR	Engine Fuel Temperature Sensor
EGT SENSOR	Exhaust Gas Temperature Sensor
EOT SENSOR	Engine Oil Temperature Sensor
EVAP CANISTER CLOSE VALVE	Evaporative Emission Canister Close Valve
EVAP CANISTER PURGE VALVE	Evaporative Emission Canister Purge Valve
FTP SENSOR	Fuel Tank Pressure Sensor
GECM	General Electronic Control Module
GPS	Global Positioning System
HID	High Intensity Discharge
HO2 SENSOR 1 / 1	Heated Oxygen Sensor – Bank 1 / Upstream
HO2 SENSOR 1 / 2	Heated Oxygen Sensor – Bank 1 / Downstream
HO2 SENSOR 2 / 1	Heated Oxygen Sensor – Bank 2 / Upstream
HO2 SENSOR 2 / 2	Heated Oxygen Sensor – Bank 2 / Downstream
IAT SENSOR	Intake Air Temperature Sensor
ICE	In-Car Entertainment System
IMT VALVE / 1	Intake Manifold Tuning Valve / Top
IMT VALVE / 2	Intake Manifold Tuning Valve / Bottom
IC	Instrument Cluster
IP SENSOR	Injection Pressure Sensor
KS	Knock Sensor
LH	Left Hand
LHD	Left Hand Drive
MAF SENSOR	Mass Air Flow Sensor
MAN	Manual Transmission
MAP SENSOR	Manifold Absolute Pressure Sensor
N/A	Normally Aspirated
NAS	North American Specification
PATS	Passive Anti-Theft System
PWM	Pulse Width Modulated
RH	Right Hand
RHD	Right Hand Drive
ROW	Rest of World
SCP	Standard Corporate Protocol Network
TCM	Transmission Control Module
TP SENSOR	Throttle Position Sensor
TP1	Throttle Position Sensor Element 1
TP2	Throttle Position Sensor Element 2
TURN	Turn Signal
TV	Television
V6	V6 Engine
VEMS	Vehicle Emergency Message System
VICS	Vehicle Information Control System
VVT VALVE / 1	Variable Valve Timing Valve / Bank 1
VVT VALVE / 2	Variable Valve Timing Valve / Bank 2
+ve	Positive
-ve	Negative
-ve BUS	Central Junction Fuse Box Ground Bus



Electrical Guide Format

This Electrical Guide is made up of two major sections. The first section, at the front of the book, provides general information for and about the use of the book, and information and illustrations to aid in the understanding of the Jaguar X-TYPE electrical / electronic systems, as well as the location and identification of components.

The second section includes the Figures, which are the basis of the book. Each Figure is identified by a Figure Number (i.e. Fig. 01.1) and Title, and is accompanied by a page of data containing information specific to that Figure.

It is recommended that the user read through the front section of the book to develop a familiarity with the layout of the book and with the system of symbols and abbreviations used. The Table of Contents should help to guide the user.

Vehicle Identification Numbers (VIN)

VIN ranges are presented throughout the book in the following manner:

→ VIN 123456 indicates “up to VIN 123456”; VIN 123456 → indicates “from VIN 123456 on”.

Jaguar X-TYPE Electrical System Architecture

Power Supplies

The Jaguar X-TYPE electrical system is a supply-side switched system. The ignition switch directly carries much of the ignition switched power supply load. Power supply is provided via three methods: direct battery power supply, ignition switched power supply, and “Battery Saver” power supply. The “Battery Saver” power supply circuit is controlled via GECM (General Electronic Control Module) internal timer circuits. Refer to Figure 01.5 for circuit activation details.

Fuse Boxes

The electrical harness incorporates a hard-wired Power Distribution Fuse Box in the engine compartment and a serviceable Central Junction Fuse Box in the front left-hand foot well. All fuses and relays (except the trailer towing accessory kit) are located in the two fuse boxes.

Vehicle Networks

The Jaguar X-TYPE employs three different networks: a CAN (Controller Area Network) for high-speed powertrain communications, an SCP (Standard Corporate Protocol) network for slower speed body systems communications, and a D2B (Optical) Network for very high-speed “real-time” audio data transfer. The D2B Network is a fiber optic network with a gateway to the remaining vehicle networks via the Audio Unit (Radio Head Unit). Technician access to the three networks and the Serial Data Link is via the Data Link Connector.

Ground Studs

Circuit ground connections are made at body studs located throughout the vehicle. There are no separate power and logic grounding systems; however, there are a certain number of components that use unique ground points.

X-TYPE INSTRUMENT PANEL

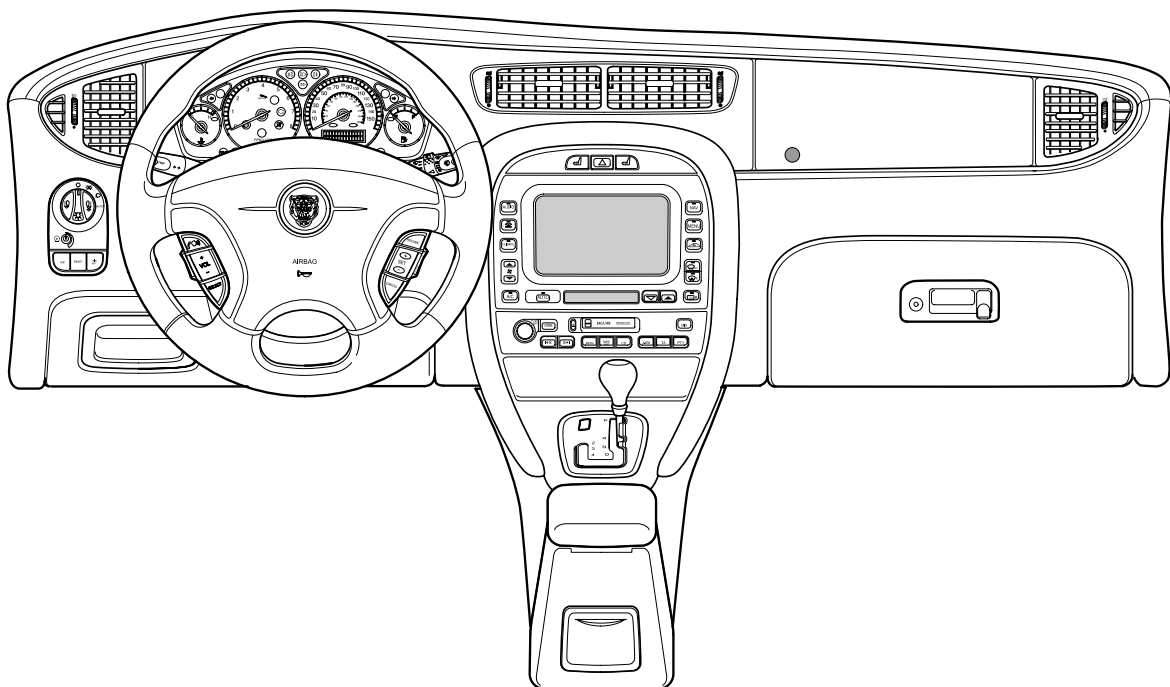



Accessory Power Relay	Fig. 01.3	Cabin Accessory Connector	Fig. 19.1
Active Security Sounder	Fig. 12.3	Capacitor (ABS / DSC / TC)	Fig. 05.1
Air Conditioning Blower Relay	Fig. 06.1	Fig. 05.2
Air Conditioning Blower Relay	Fig. 06.2	Fig. 05.3
Air Conditioning Compressor Clutch	Fig. 03.2	Caravan Connector	Fig. 08.5
.....	Fig. 03.4	CD Autochanger	Fig. 15.1
Air Conditioning Compressor Clutch Relay	Fig. 03.2	Fig. 15.2
Air Conditioning Control Module (Automatic, Panel)	Fig. 06.2	Fig. 20.3
.....	Fig. 09.2	Fig. 20.4
.....	Fig. 20.1	Cellular Phone Control Module	Fig. 16.1
Air Conditioning Control Module (Manual, Panel)	Fig. 06.1	Fig. 16.2
.....	Fig. 09.2	Fig. 16.3
.....	Fig. 20.1	Fig. 16.4
Air Conditioning Control Module (Remote)	Fig. 06.2	Fig. 20.3
.....	Fig. 20.1	Fig. 20.4
Air Conditioning Pressure Sensor	Fig. 03.2	Central Junction Fuse Box	Fig. 01.1
.....	Fig. 03.4	Fig. 01.2
Air Temperature Blend Actuator	Fig. 06.1	Fig. 01.3
.....	Fig. 06.2	Fig. 01.4
Airbag Deactivated Indicator Lamp – Passenger	Fig. 17.1	Fig. 01.5
Ambient Temperature Sensor	Fig. 06.2	Fig. 03.1
Antenna Module	Fig. 15.1	Fig. 03.3
.....	Fig. 15.2	Fig. 03.4
Anti-Lock Braking System Control Module	Fig. 05.1	Fig. 05.1
.....	Fig. 20.1	Fig. 05.2
Anti-Lock Braking / Traction Control Control Module	Fig. 05.3	Fig. 05.3
.....	Fig. 20.1	Fig. 06.1
APP Sensor	Fig. 03.1	Fig. 06.2
Audio Control Switches	Fig. 15.1	Fig. 08.1
.....	Fig. 15.2	Fig. 08.2
.....	Fig. 16.3	Fig. 08.3
.....	Fig. 16.4	Fig. 08.4
.....	Fig. 16.5	Fig. 08.5
Audio Unit	Fig. 09.2	Fig. 08.6
.....	Fig. 12.3	Cigar Lighter	Fig. 09.2
.....	Fig. 15.1	Fig. 19.1
.....	Fig. 15.2	CKP Sensor	Fig. 03.1
.....	Fig. 16.1	Fig. 03.3
.....	Fig. 16.2	Clutch Cancel Switch	Fig. 03.2
.....	Fig. 16.3	Fig. 03.4
.....	Fig. 16.4	Fig. 04.1
.....	Fig. 16.5	Fig. 04.2
.....	Fig. 20.2	Fig. 04.3
.....	Fig. 20.3	Clutch Pedal Safety Switch	Fig. 02.1
.....	Fig. 20.4	Fig. 04.1
Autolamps Sensor	Fig. 08.1	Fig. 04.2
Automatic Transmission	Fig. 04.1	Fig. 04.3
.....	Fig. 04.2	Clutch Pedal Safety Switch	Fig. 02.1
.....	Fig. 04.3	Fig. 04.1
Battery Saver Relay	Fig. 01.5	Fig. 04.2
Battery	Fig. 01.1	Fig. 04.3
.....	Fig. 02.1	CMP Sensors	Fig. 03.1
.....	Fig. 02.2	Fig. 03.3
Blower (Automatic)	Fig. 06.2	Cooling Fans	Fig. 03.2
Blower (Manual)	Fig. 06.1	Fig. 03.4
Blower Series Resistor	Fig. 06.1	Cooling Fan Module	Fig. 03.2
Brake Cancel Switch	Fig. 03.2	Fig. 03.4
.....	Fig. 03.4	Curtain Airbag Igniters	Fig. 17.1
Brake Fluid Switch	Fig. 07.1	Data Link Connector	Fig. 20.1
Brake On / Off Switch	Fig. 03.1	Fig. 20.2
.....	Fig. 03.3	Defrost Door Actuator	Fig. 06.1
.....	Fig. 03.4	Fig. 06.2
.....	Fig. 05.1	Dip Beam Relay	Fig. 08.1
.....	Fig. 05.2	Fig. 08.2
.....	Fig. 05.3	Fig. 08.7
.....	Fig. 08.3	Discharge Temperature Sensor	Fig. 06.1
.....	Fig. 08.4	Fig. 06.2
.....	Fig. 08.5	Door Courtesy Lamps	Fig. 09.1
.....	Fig. 08.6	Door Latch Assembly – LH Front	Fig. 07.2
Brake Pressure Sensor	Fig. 05.2	Fig. 09.1
		Fig. 12.1
		Fig. 12.2
		Fig. 12.3
		Fig. 14.1
		Fig. 14.2
		Fig. 14.3



Door Latch Assembly – RH Front	Fig. 07.2	Fuel Pump (2.5L & 3.0L)	Fig. 03.2
.....	Fig. 09.1	Fuel Pump (2.0L)	Fig. 03.4
.....	Fig. 12.1	Fuel Pump Module (2.5L & 3.0L)	Fig. 03.2
.....	Fig. 12.2	Fuel Pump Relay (2.0L)	Fig. 03.4
.....	Fig. 12.3	General Electronic Control Module	Fig. 01.5
.....	Fig. 14.3	Fig. 02.1
Door Latch Assemblies – Rear	Fig. 09.1	Fig. 02.2
.....	Fig. 12.1	Fig. 07.1
.....	Fig. 12.2	Fig. 07.2
.....	Fig. 12.3	Fig. 08.1
Door Mirrors	Fig. 06.1	Fig. 08.2
.....	Fig. 06.2	Fig. 08.3
.....	Fig. 10.2	Fig. 08.4
Door Switch Pack – Driver	Fig. 09.2	Fig. 08.5
.....	Fig. 10.2	Fig. 08.6
.....	Fig. 14.1	Fig. 09.1
.....	Fig. 14.2	Fig. 12.1
Door Switch Pack – Passenger	Fig. 09.2	Fig. 12.2
.....	Fig. 14.1	Fig. 12.3
.....	Fig. 14.2	Fig. 13.1
Door Switch Packs – Rear	Fig. 09.2	Fig. 13.2
.....	Fig. 14.1	Fig. 14.1
.....	Fig. 14.2	Fig. 14.2
Dual Airbag Igniters	Fig. 17.1	Fig. 14.3
Dynamic Stability Control Control Module	Fig. 05.2	Fig. 19.1
Dynamic Stability Control Switch	Fig. 05.2	Fig. 20.2
.....	Fig. 09.2	Generator	Fig. 02.1
ECT Sensor	Fig. 03.1	Fig. 02.2
.....	Fig. 03.3	Glove Box Lamp	Fig. 08.1
EFT Sensor	Fig. 03.1	Fig. 08.2
Electrochromic Rear View Mirror	Fig. 10.1	Fig. 09.1
EMS Control Relay	Fig. 01.6	Handset Receiver (NAS)	Fig. 16.2
Engine Control Module (2.5L & 3.0L)	Fig. 02.1	Fig. 16.4
.....	Fig. 03.1	Handset Receiver (ROW)	Fig. 16.1
.....	Fig. 03.2	Fig. 16.3
.....	Fig. 04.1	Hazard Switch	Fig. 08.2
.....	Fig. 04.2	Fig. 08.3
.....	Fig. 04.3	Fig. 08.4
.....	Fig. 12.3	Fig. 08.5
.....	Fig. 20.1	Fig. 08.6
.....	Fig. 20.2	Hazard, Seat Heater Switches	Fig. 09.2
Engine Control Module (2.0L)	Fig. 02.2	Headlamp Leveling Control Module	Fig. 08.7
.....	Fig. 03.3	Fig. 20.1
.....	Fig. 03.4	Fig. 20.2
.....	Fig. 04.1	Headlamp Units	Fig. 08.1
.....	Fig. 04.2	Fig. 08.2
.....	Fig. 04.3	Fig. 08.7
.....	Fig. 12.3	Heated Rear Window	Fig. 06.1
.....	Fig. 20.1	Fig. 06.2
.....	Fig. 20.2	Fig. 15.1
EOT Sensor	Fig. 03.1	Fig. 15.2
.....	Fig. 03.3	Heated Rear Window Relay	Fig. 06.1
EVAP Canister Close Valve	Fig. 03.1	Fig. 06.2
EVAP Canister Purge Valve	Fig. 03.1	High Mount Stop Lamp	Fig. 08.3
.....	Fig. 03.3	Fig. 08.4
Evaporator Temperature Sensor	Fig. 06.1	Fig. 08.5
Evaporator Temperature Sensor	Fig. 06.2	Fig. 08.6
Fog Lamps	Fig. 08.1	HO2 Sensors	Fig. 03.1
.....	Fig. 08.2	Fig. 03.3
Fold Flat Module	Fig. 10.2	Hood Security Switch	Fig. 12.3
Footwell Lamps	Fig. 09.1	Horn Relay	Fig. 12.3
Fresh / Recirculation Flap Actuator	Fig. 06.1	Fig. 19.1
.....	Fig. 06.2	Horn Switch	Fig. 19.1
Front Axle Sensor	Fig. 08.7	Horns	Fig. 12.3
Front Impact Sensor	Fig. 17.1	Fig. 19.1
FTP Sensor	Fig. 03.1	Idle Speed Control Valve	Fig. 03.3
Fuel Injectors	Fig. 03.2	Ignition Capacitor	Fig. 03.2
.....	Fig. 03.4	Fig. 03.4
Fuel Level Sensors	Fig. 07.1	Ignition Modules and Coils	Fig. 03.2
		Fig. 03.4
		Ignition Relay	Fig. 01.4



Ignition Switch	Fig. 01.1	Navigation GPS Antenna	Fig. 16.6
.....	Fig. 01.3	Fig. 16.7
.....	Fig. 01.4	Oil Pressure Switch	Fig. 07.1
.....	Fig. 02.1	Output Speed Sensor	Fig. 04.1
.....	Fig. 02.2	Panel / Floor Actuator	Fig. 06.1
.....	Fig. 04.1	Fig. 06.2
.....	Fig. 04.2	Parking Aid Control Module	Fig. 18.1
.....	Fig. 04.3	Fig. 20.2
.....	Fig. 07.2	Parking Aid Sensors	Fig. 18.1
.....	Fig. 12.1	Parking Aid Sounder	Fig. 18.1
.....	Fig. 12.2	Passive Anti-Theft System Transceiver	Fig. 02.1
.....	Fig. 12.3	Fig. 02.2
IMT Solenoid Valves	Fig. 03.1	Fig. 12.3
.....	Fig. 03.3	Passive Security Sounder	Fig. 12.3
In-Car Temperature Sensor	Fig. 06.2	Power Distribution Fuse Box	Fig. 01.1
Inclination Sensor	Fig. 12.3	Fig. 01.2
Inertia Switch	Fig. 01.1	Fig. 01.3
.....	Fig. 01.4	Fig. 01.6
.....	Fig. 12.1	Fig. 02.1
.....	Fig. 12.2	Fig. 02.2
Instrument Cluster	Fig. 02.1	Fig. 03.1
.....	Fig. 02.2	Fig. 03.2
.....	Fig. 07.1	Fig. 03.4
.....	Fig. 07.2	Fig. 04.1
.....	Fig. 08.3	Fig. 04.2
.....	Fig. 09.2	Fig. 04.3
.....	Fig. 10.1	Fig. 06.1
.....	Fig. 12.1	Fig. 06.2
.....	Fig. 12.2	Fig. 08.1
.....	Fig. 12.3	Fig. 08.2
.....	Fig. 20.1	Fig. 08.7
.....	Fig. 20.2	Fig. 12.3
IP Sensor	Fig. 03.1	Fig. 13.1
J Gate Assembly	Fig. 04.1	Fig. 13.2
.....	Fig. 04.2	Fig. 19.1
.....	Fig. 04.3	Power Wash Pump	Fig. 13.1
.....	Fig. 07.2	Fig. 13.2
.....	Fig. 09.2	Power Wash Pump Relay	Fig. 13.1
.....	Fig. 20.1	Fig. 13.2
JaguarNet GPS Antenna	Fig. 16.1	Rain Sensing Control Module	Fig. 13.2
.....	Fig. 16.2	Rain Sensor	Fig. 13.2
.....	Fig. 16.3	Rear Axle Sensor	Fig. 08.7
.....	Fig. 16.4	Rear Interior Lamp	Fig. 09.1
Knock Sensor	Fig. 03.1	Restraints Control Module	Fig. 07.1
.....	Fig. 03.3	Fig. 07.2
License Plate Lamps	Fig. 08.3	Fig. 20.2
.....	Fig. 08.4	Reverse Lamps Relay	Fig. 08.3
.....	Fig. 08.5	Reverse Lamps Switch	Fig. 04.1
.....	Fig. 08.6	Fig. 04.2
MAF Sensor	Fig. 03.1	Fig. 04.3
.....	Fig. 03.3	Fig. 08.3
Main Beam / Front Fog Relay	Fig. 08.1	Roof Console	Fig. 09.1
.....	Fig. 08.2	Fig. 09.2
MAP Sensor	Fig. 03.1	Fig. 12.3
.....	Fig. 03.3	Fig. 14.3
Master Lighting Switch	Fig. 07.1	Fig. 16.1
.....	Fig. 08.1	Fig. 16.2
.....	Fig. 08.2	Fig. 16.3
.....	Fig. 08.3	Fig. 16.4
.....	Fig. 08.4	Fig. 16.5
.....	Fig. 08.5	Fig. 16.7
.....	Fig. 08.6	Fig. 19.1
.....	Fig. 08.7	Fig. 20.2
.....	Fig. 09.2	Seat Back Heaters	Fig. 11.3
Mid Bass Speakers	Fig. 15.2	Seat Belt Pretensioner Igniters	Fig. 17.1
Navigation Control Module	Fig. 16.1	Seat Belt Switches	Fig. 17.1
.....	Fig. 16.2	Seat Cushion Heaters	Fig. 11.3
.....	Fig. 16.3	Seat Heater Modules	Fig. 11.3
.....	Fig. 16.4	Seat Heater Switches	Fig. 11.3
.....	Fig. 16.6	Seat Lumbar Pumps	Fig. 11.1
.....	Fig. 16.7	Seat Lumbar Switch Packs	Fig. 11.1
.....	Fig. 20.2		
.....	Fig. 20.3		
.....	Fig. 20.4		



Seat Movement Motors	Fig. 11.1	Transmission Control Module	Fig. 04.1
.....	Fig. 11.2	Fig. 04.2
Seat Position Switch – Driver	Fig. 17.1	Fig. 04.3
Seat Switch Packs	Fig. 11.1	Fig. 20.1
.....	Fig. 11.2	Transmission Range Sensor	Fig. 02.1
Seat Weight Pressure Sensor – Passenger	Fig. 17.1	Fig. 02.2
Seat Weight Sensing Control Module – Passenger	Fig. 17.1	Fig. 04.1
Security Indicator	Fig. 12.3	Fig. 04.2
Side Airbag Igniters	Fig. 17.1	Trunk Accessory Connector	Fig. 19.1
Side Impact Sensors	Fig. 17.1	Trunk Lamp	Fig. 09.1
Side Marker Lamp – Front	Fig. 08.1	Trunk Lock Motor	Fig. 09.1
.....	Fig. 08.2	Fig. 12.1
Side Marker Lamp – Rear	Fig. 08.3	Fig. 12.2
.....	Fig. 08.6	Fig. 12.3
Sliding Roof Control Module	Fig. 14.3	Trunk Release Switch	Fig. 12.1
Solar Sensor	Fig. 06.2	Fig. 12.2
Speakers	Fig. 15.1	Turn Repeaters	Fig. 08.1
Speed Control Switches	Fig. 03.2	Fig. 08.2
.....	Fig. 03.4	Turn Signal Switch	Fig. 07.1
Speed Control Control Module	Fig. 03.4	Fig. 08.1
Starter Motor	Fig. 02.1	Fig. 08.2
.....	Fig. 02.2	Fig. 08.3
Starter Relay	Fig. 02.1	Fig. 08.4
.....	Fig. 02.2	Fig. 08.5
Steering Angle Sensor	Fig. 05.2	Fig. 08.6
.....	Fig. 20.1	Tweeters	Fig. 15.2
Steering Wheel	Fig. 09.2	Vacuum Module	Fig. 05.1
Sub Woofer	Fig. 15.2	Fig. 05.2
Tail Lamp Units	Fig. 08.3	Fig. 05.3
.....	Fig. 08.4	Vacuum Pump	Fig. 05.1
.....	Fig. 08.5	Fig. 05.2
.....	Fig. 08.6	Fig. 05.3
TCM Relay	Fig. 04.1	Vanity Mirror Lamps	Fig. 09.1
.....	Fig. 04.2	Variable Assist Servo	Fig. 10.1
.....	Fig. 04.3	Vehicle Information Antenna and Amplifier	Fig. 16.7
Telematics Display	Fig. 09.2	Vehicle Information Control Module	Fig. 16.7
.....	Fig. 16.1	Vehicle Information Sensor	Fig. 16.7
.....	Fig. 16.2	Vehicle Information Control Module	Fig. 16.3
.....	Fig. 16.3	Fig. 16.4
.....	Fig. 16.4	Fig. 16.5
.....	Fig. 16.6	Fig. 20.3
.....	Fig. 16.7	Fig. 20.4
Telephone Antenna, Bumper (NAS)	Fig. 16.2	VVT Solenoid Valves	Fig. 03.1
.....	Fig. 16.4	Fig. 03.3
Telephone Antenna, Bumper (ROW)	Fig. 16.1	Washer Fluid Level Switch	Fig. 07.1
.....	Fig. 16.3	Wheel Speed Sensors	Fig. 05.1
Telephone Antenna, JaguarNet (NAS)	Fig. 16.2	Fig. 05.2
.....	Fig. 16.4	Fig. 05.3
Telephone Antenna, JaguarNet (ROW)	Fig. 16.1	Window Motor Assemblies	Fig. 14.1
.....	Fig. 16.3	Fig. 14.2
Television Antennas and Amplifiers	Fig. 16.7	Windshield Heaters	Fig. 06.1
Throttle Body	Fig. 03.1	Fig. 06.2
Throttle Motor	Fig. 03.1	Windshield Heater Relay	Fig. 06.1
Throttle Motor Relay	Fig. 03.1	Fig. 06.2
TP Sensor (2.5L & 3.0L)	Fig. 03.1	Windshield Washer Pump	Fig. 13.1
TP Sensor (2.0L)	Fig. 03.3	Fig. 13.2
Traction Control Switch	Fig. 05.3	Windshield Wiper Motor Relay	Fig. 13.1
Trailer Connector	Fig. 08.4	Fig. 13.2
.....	Fig. 08.5	Wiper Motor Assembly	Fig. 13.1
.....	Fig. 08.6	Fig. 13.2
Trailer Towing Control Module	Fig. 08.4	Wiper Switch Assembly	Fig. 13.1
.....	Fig. 08.5	Fig. 13.2
.....	Fig. 08.6	Yaw Rate Sensor	Fig. 05.2
Trailer Towing Rear Accessory Connector	Fig. 08.4	Fig. 20.1
.....	Fig. 08.5		
.....	Fig. 08.6		
Transit Isolation Device	Fig. 01.1		



Figure and Data Page Layout

Figure Pages

Each Figure represents a specific electrical system of the vehicle. The Figures are arranged numerically by system (**01 - Power Distribution, 02 - Battery; Starter; Generator, etc.**) with variations in the system identified by a numeral following a decimal point (**01.1, 01.2, etc.**). Refer to the **Table of Contents: Figures** for a complete list of the Figures.

The Figures **01 - Power Distribution** detail the distribution of power to each of the systems. Numbered reference symbols refer the user to a specific Figure and from a specific Figure back to the Power Distribution Figures. This method eliminates the need to include detailed Power Distribution information on each of the Figures. The reference symbols are defined on page 12.

Each Figure appears on a right-hand page with a corresponding Data page to the left. The Figure and Data pages are folding pages. The user must fold out both pages in order to access all the information provided.

Data Pages

The Data page includes information to assist the user in identifying and locating components, connectors and grounds. This information is supplemented by the illustrations in this front section of the book.

When network data is required for the understanding of a particular circuit, the user is directed to the Appendix.

Most circuits that incorporate a control module include pinout information. The characteristics listed are approximately those that can be expected at the control module connector pins with all circuit connections made and all components connected and fitted. This information is provided to assist the user in understanding circuit operation and should be used FOR REFERENCE ONLY.



CONTROL MODULE PIN OUT INFORMATION

FIGURE NUMBER

COMPONENT, CONNECTOR AND GROUND INFORMATION

CONTROL MODULE PIN-OUT INFORMATION

General Electronic Control Module

Pin	Description and Characteristic
4	IP4-18 SCP
5	IP4-19 SCP
1	IP4-2 KEY-IN IGNITION SWITCH (a) - WHEN KEY-IN

Instrument Cluster

Pin	Description and Characteristic
D	IP2-1 INTA 1: BROADCAST COMMUNICATION
D	IP2-4 INTA 2: BROADCAST COMMUNICATION
I	IP2-5 INTA GROUND: GROUND
I	IP2-6 INTA TRANSDUCER POWER: (a) - CAN +
C	IP2-10 CAN +
C	IP2-11 CAN -
S	IP2-20 SCP
S	IP2-21 SCP

Engine Control Module (2.5L & 3.0L)

Pin	Description and Characteristic
I	EN4-04 ENGINE DRIVE: (a)
I	EN4-01 PARK TRACTION SWITCH (AUTOMATIC TRANSMISSION): NORMALLY CLOSED (GROUND WHEN ACTIVATED)
I	EN4-01 CLUTCH PEDAL SAFETY SWITCH (MANUAL TRANSMISSION): NORMALLY OPEN (a) - WHEN ACTIVATED
D	EN4-01 STARTER RELAY DRIVE: TO ACTUATE, LOW IMPEDANCE CIRCUIT TO GROUND
I	EN4-03 GENERATOR CHARGE: VARIABLE VOLTAGE
D	EN4-04 GENERATOR FIELD RETURN SIGNAL: VARIABLE VOLTAGE ON GENERATOR OPERATING CONDITION
I	EN4-09 GENERATOR LOAD: (a) - NORMAL, AFTER START SWITCH ON; GROUND - GENERATOR FAILURE, AFTER START SWITCH ON
D	EN4-10 CAN +
C	EN4-10 CAN -

NOTE: Refer to the Appendix at the rear of this book for Network Messages.

Fig. 02.1

Component	Connector(s)	Connector Description	Location
AUTOSTOP	-	-	-
CLUTCH PEDAL SAFETY SWITCH	PA1	2-WAY / BLACK	ENGINE COMPARTMENT / TOP OF CLUTCH PEDAL
ENGINE CONTROL MODULE (2.5L & 3.0L)	EN4	18-WAY / BLACK	ENGINE COMPARTMENT / FRONT BULBHEAD (a) SIDE
GENERAL ELECTRONIC CONTROL MODULE	GM4	23-WAY / GREEN	ENGINE COMPARTMENT / FRONT BULBHEAD (a) SIDE
	GM5	23-WAY / GREEN	ENGINE COMPARTMENT / FRONT BULBHEAD (a) SIDE
	GM6	23-WAY / GREEN	ENGINE COMPARTMENT / FRONT BULBHEAD (a) SIDE
	GM7	23-WAY / GREEN	ENGINE COMPARTMENT / FRONT BULBHEAD (a) SIDE
	GM8	23-WAY / GREEN	ENGINE COMPARTMENT / FRONT BULBHEAD (a) SIDE
GENERATOR	GR1	5-WAY / BLACK	ENGINE BAY 1, FRONT
IGNITION SWITCH	IP1	7-WAY / BLACK	STEERING COLUMN
INSTRUMENT CLUSTER	IP2	20-WAY / YELLOW	INSTRUMENT PANEL
PASSIVE ANTI-THIEF SYSTEM TRANSDUCER	PT1	20-WAY / YELLOW	STEERING COLUMN, IGNITION SWITCH
POWER DISTRIBUTION FUSE BOX	PF1	20-WAY / YELLOW	ENGINE COMPARTMENT / (a) SIDE
STARTER MOTOR (SERVO PRODUCTION)	SM1	5-WAY / GREEN	ENGINE BAY 1, SIDE
STARTER MOTOR (LATER PRODUCTION)	ST1	1-WAY / VIOLET	ENGINE BAY 1, SIDE
	ST2	1-WAY / VIOLET	ENGINE BAY 1, SIDE
STARTER RELAY	SR1	1-WAY / VIOLET	ENGINE BAY 1, SIDE
TRANSMISSION RANGE SENSOR	TR1	10-WAY / BLACK	POWER DISTRIBUTION FUSE BOX (a) / TOP OF TRANSMISSION

Connector	Connector Description	Location
EN4	18-WAY / JUNCTION BOX WIRING TO ENGINE HARNESS	ENGINE HARNESS
GM4	23-WAY / BLACK / JUNCTION BOX WIRING TO ENGINE HARNESS	ADJACENT TO L/R SUSPENSION TOWER
GM5	23-WAY / GREEN / JUNCTION BOX WIRING TO ENGINE HARNESS	ADJACENT TO CENTRAL JUNCTION FUSE BOX
GM6	23-WAY / GREY / INSTRUMENT PANEL WIRING TO JUNCTION BOX HARNESS	IN LOWER A-POST
GM7	23-WAY / BLACK / ENGINE HARNESS TO JUNCTION BOX HARNESS	ADJACENT TO CENTRAL JUNCTION FUSE BOX

Grounds	Location
G1	ENGINE COMPARTMENT / ENGINE BLOCK
G2	ENGINE COMPARTMENT / UNDER BATTERY TRAY
G3	PASSAGE COMPARTMENT / L/R CROSS CAR BEAM

FOR CONTROL MODULE PIN-OUT INFORMATION, UNFOLD PAGE TO LEFT.

The following abbreviations are used to represent values for Control Module Pin-Out data:

I	Input	PG	Power Ground	CAN	CAN Network	D	Serial and Encoded Data
O	Output	SS	Sensor / Signal Supply V	SCP	SCP Network	V	Voltage (DC)
B+	Battery Voltage	SG	Sensor / Signal Ground	DZ	D2B Network	PWM	Pulse Width Modulated

CAUTION: The information on this data page is furnished to aid the user in understanding circuit operation. THIS INFORMATION SHOULD BE USED FOR REFERENCE ONLY.

NOTE: The characteristic listed are approximately those that can be expected at the control module connector pins with all circuit connections made and all components connected and fitted.

Refer to the front of this book for detailed information and illustrations regarding the location and identification of harnesses, relays, fuses, grounds, control modules and control module pins.

DATE OF ISSUE: December 2001

DATE OF ISSUE: December 2001

DATE OF ISSUE

DATA PAGE

FIGURE MODEL RANGE AND YEAR TITLE FIGURE NUMBER

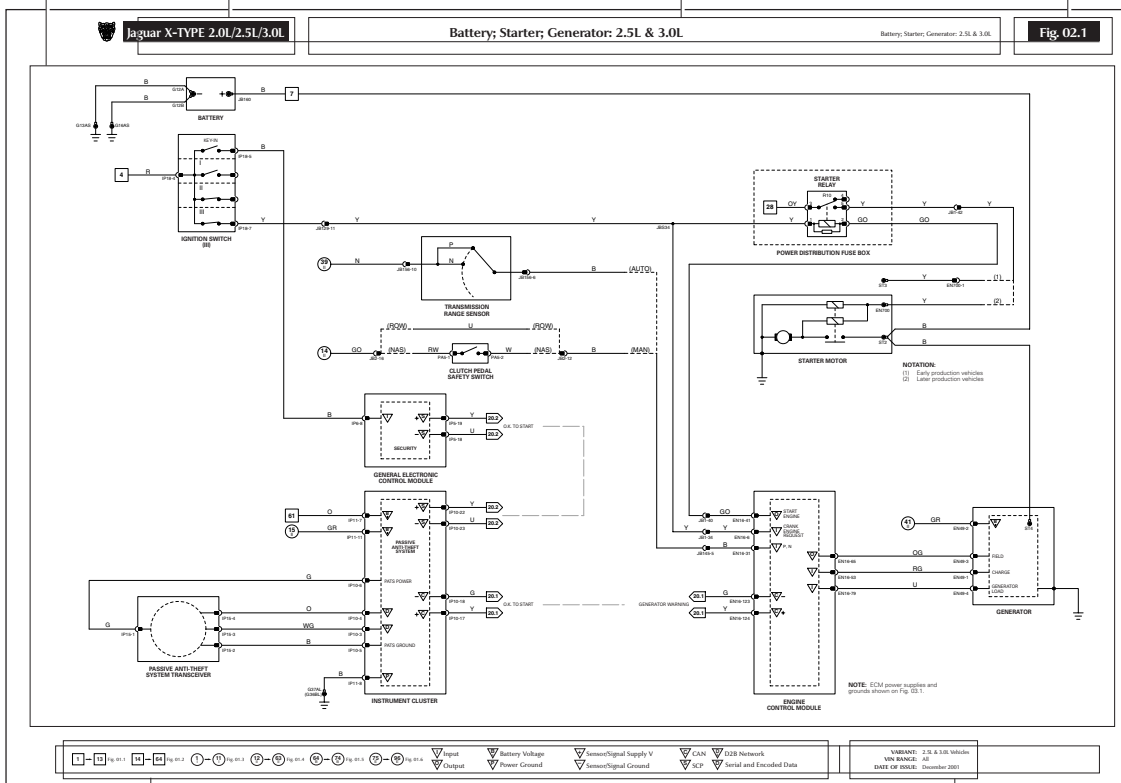

KEY TO REFERENCE SYMBOLS









FIGURE PAGE

VARIANT, VIN RANGE AND DATE OF ISSUE













NOTE: In the examples on this page, an 'X' is used where a number would appear on an actual Figure.

Reference Symbols

-  Battery power supply
-  Ignition switched auxiliary power supply (key I)
-  Ignition switched power supply (key II, III)
-  Ignition switched Battery Saver power supply
-  Engine Management System power supply
-  Figure number reference
-  Controller Area Network
-  Standard Corporate Protocol network
-  D2B network







Control Module Pin Symbols

-  Input
-  Output
-  Battery voltage
-  Power ground
-  Sensor/signal supply V *
-  Sensor/signal ground **
-  CAN network
-  SCP network
-  D2B network
-  Serial and encoded data

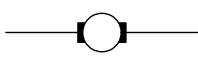
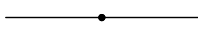
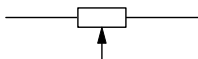
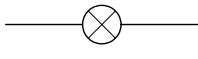
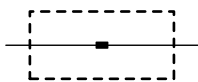
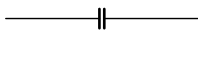
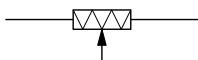
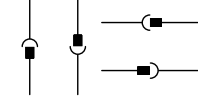
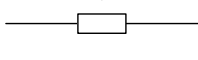
* May also indicate Reference Voltage.

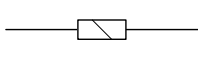
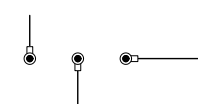
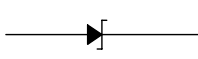
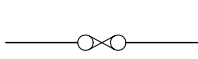
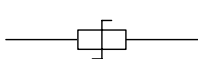
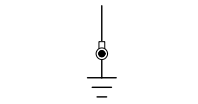
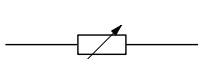
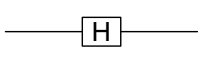
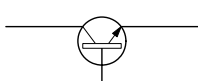
** May also indicate Reference Ground or Logic Ground.
Refer to Control Module Pin-Out Information.

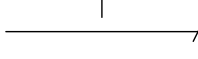
Wiring Symbols

- | | | | |
|----------------------------|---|--|---------------------------------|
| Splice |  |  | Motor |
| Simplified splice |  |  | Potentiometer |
| Bulb |  |  | Power distribution box terminal |
| Capacitor |  |  | Pressure transducer |
| Connector |  |  | Resistor |
| Diode |  |  | Solenoid |
| Eyelet and stud |  |  | Suppression diode |
| Fuse |  |  | Suppression resistor |
| Ground |  |  | Thermistor |
| Hall effect sensor |  |  | Transistor |
| Light emitting diode (LED) |  |  | Wire continued |
| | |  | Zener diode |



Harness Codes

AC	Climate Control
AL	LH Side Airbag
AR	RH Side Airbag
BL	LH Rear Door
BR	RH Rear Door
CA	Cabin
EN	Engine
FB	Front Bumper
FL	LH Front Door
FR	RH Front Door
FT	Fuel Tank
GC	Cooling Pack
IL	Injector Rail
IP	Instrument Panel
JB	Junction Box
LF	LH Front Wheel Speed Sensor
LR	LH Rear Wheel Speed Sensor
LS	LH Front Seat
NA	Navigation System
PA	Pedals
PH	Telephone
RB	Rear Bumper
RC	Roof Console
RF	RH Front Wheel Speed Sensor
RR	RH Rear Wheel Speed Sensor
RS	RH Front Seat
TL	Trunk Lid
TM	Trunk Main
VM	Vacuum Module
VP	Vacuum Pump

Wiring Color Codes

N	Brown	O	Orange
B	Black	S	Slate
W	White	L	Light
K	Pink	U	Blue
G	Green	P	Purple
R	Red	BRD	Braid
Y	Yellow	BOF	Fiber optic (D2B Network)

Code Numbering

When numbering connectors, grounds and splices, Jaguar Engineering uses a three-position format: AC001, AC002, etc. Because space is limited in this Electrical Guide the codes have, in most cases, been shortened. Thus AC001-001 becomes AC1-1, AC002-001 becomes AC2-1, etc.



Grounds

There may be up to three eyelets on one ground stud. A, B and C are used to indicate the position of the eyelet on the stud: A – first (bottom), B – second (middle), C – third (top). Two eyelet variations are used: a single eyelet and an eyelet pair. The single eyelet has a single ‘leg’, which is identified by an S; the eyelet pair has two ‘legs’, identified as L (left) or R (right).

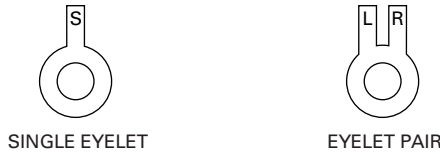

EXAMPLE:



On figures where LHD and RHD circuits are combined and the ground designation differs from LHD to RHD, the RHD ground is shown in parentheses. If the ground designation is the same for LHD and RHD, only one ground designation is used.

EXAMPLE:



Relays

All relays are located in the Power Distribution Fuse Box and the Central Junction Fuse Box. Relays do not have a separate relay connector (base). All relays use the ISO pin numbering system (1, 2, 3, 4, 5). Each relay in the vehicle is identified by a unique ‘R’ number.

EXAMPLE:



Fuses

All fuses are located in the Power Distribution Fuse Box and the Central Junction Fuse Box. Each fuse in the vehicle is identified by a unique ‘F’ number.

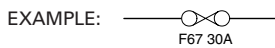

Networks

In most instances, networks are shown as a broken grey line to indicate that there is network communication between the depicted control modules. Refer to Figures 20.1, 20.2, 20.3 and 20.4 for circuit details.

EXAMPLE:

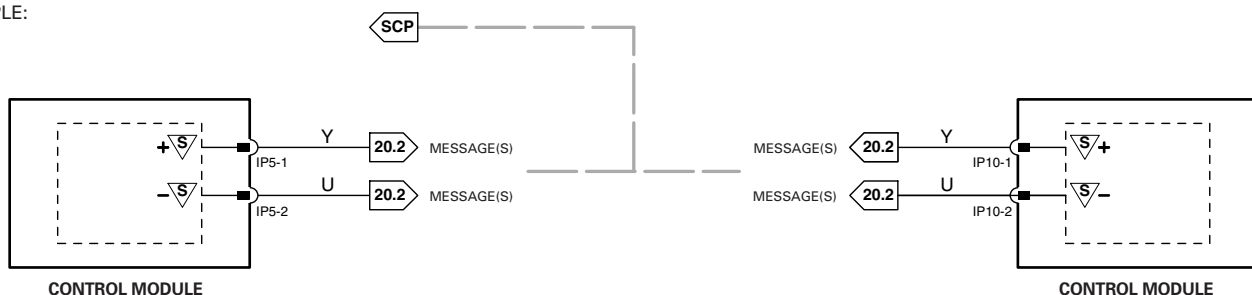

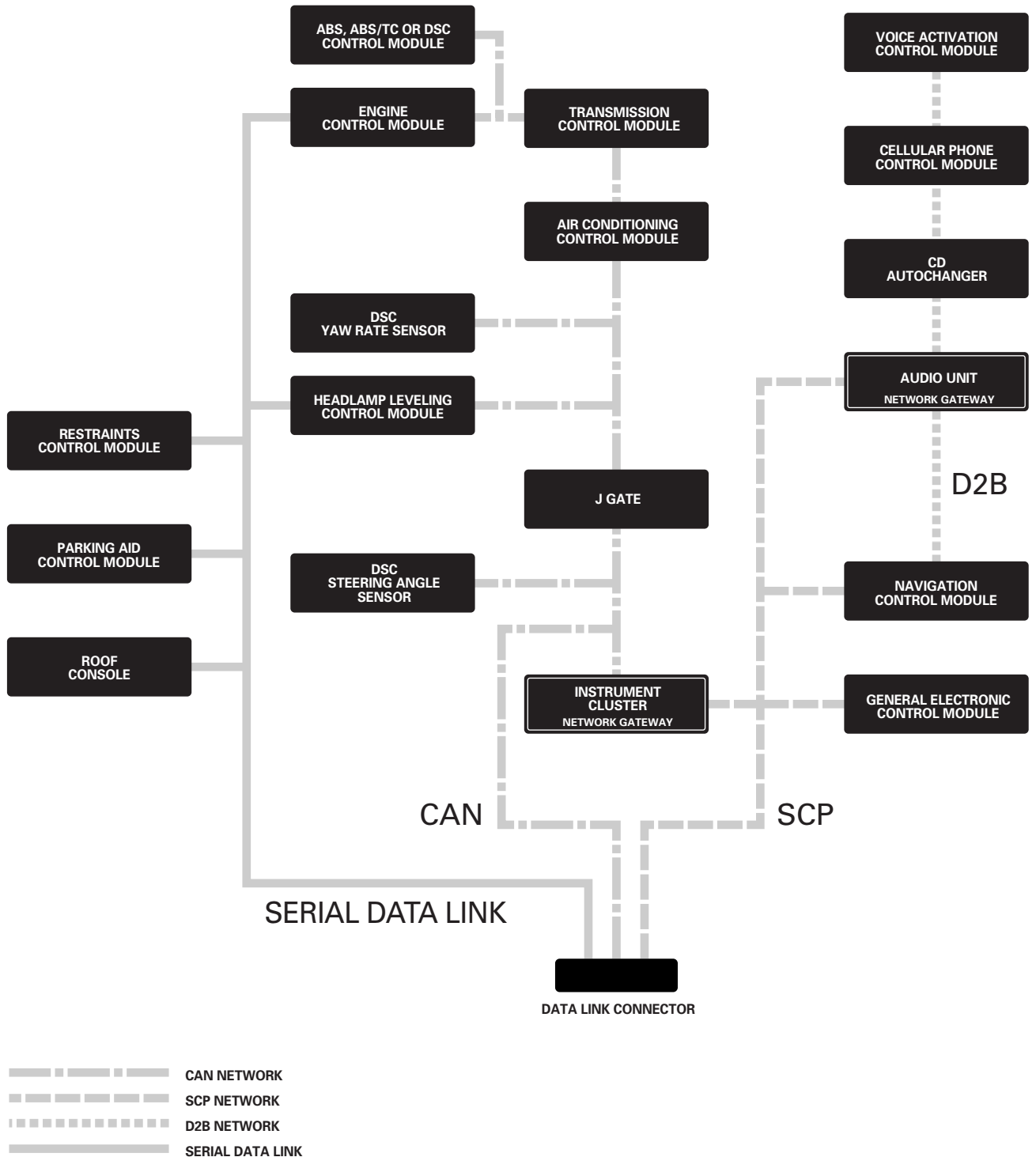

NOTE: TYPICAL NETWORK CONFIGURATION. REFER TO FIGURES 20.1, 20.2, 20.3 AND 20.4 FOR CIRCUIT DETAILS.



POWER DISTRIBUTION FUSE BOX

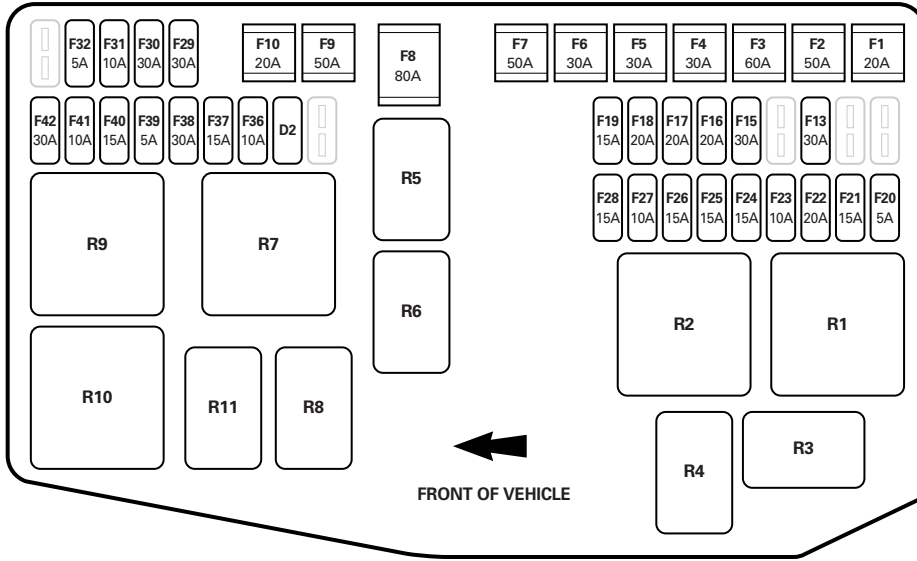

- R1 WINDSHIELD WIPER MOTOR RELAY
- R2 WINDSHIELD HEATER RELAY
- R3 HORN RELAY
- R4 ACCESSORY POWER RELAY
- R5 POWER WASH PUMP RELAY
- R6 A/C COMPRESSOR CLUTCH RELAY
- R7 EMS CONTROL RELAY
- R8 TCM RELAY
- R9 DIP BEAM RELAY
- R10 STARTER RELAY
- R11 THROTTLE MOTOR RELAY (2.5L & 3.0L); FUEL PUMP RELAY (2.0L)

CENTRAL JUNCTION FUSE BOX

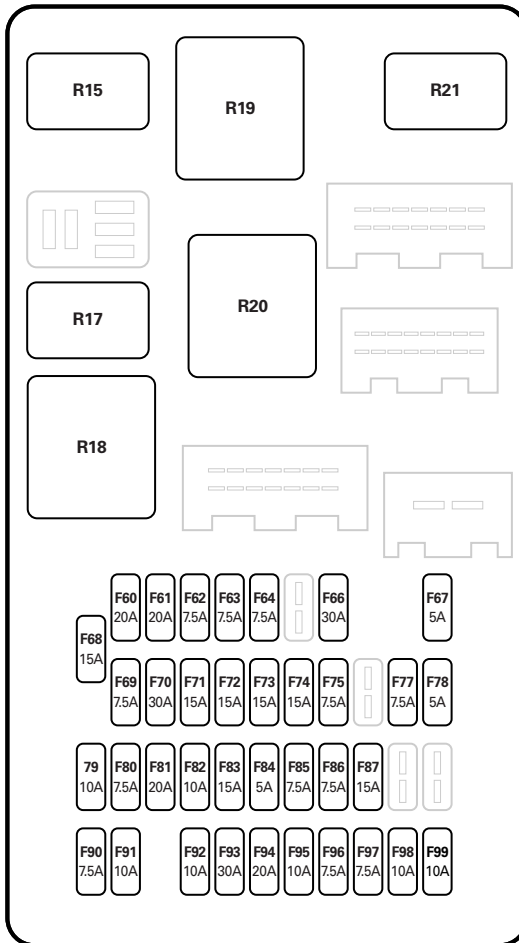

- R15 MAIN BEAM / FRONT FOG RELAY
- R16 NOT USED
- R17 REVERSE LAMPS RELAY
- R18 IGNITION RELAY
- R19 HEATED REAR WINDOW RELAY
- R20 A/C BLOWER RELAY
- R21 BATTERY SAVER RELAY



CENTRAL JUNCTION FUSE BOX – FRONT

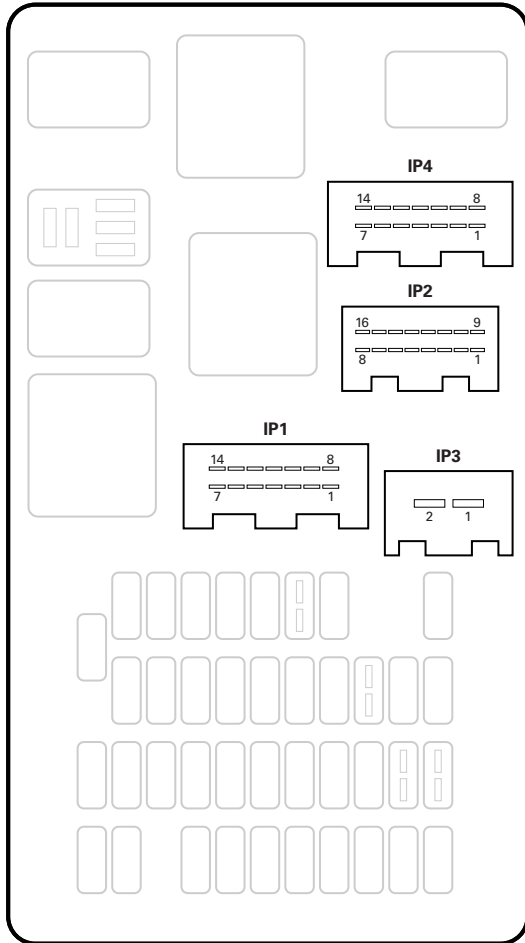

CENTRAL JUNCTION FUSE BOX – REAR

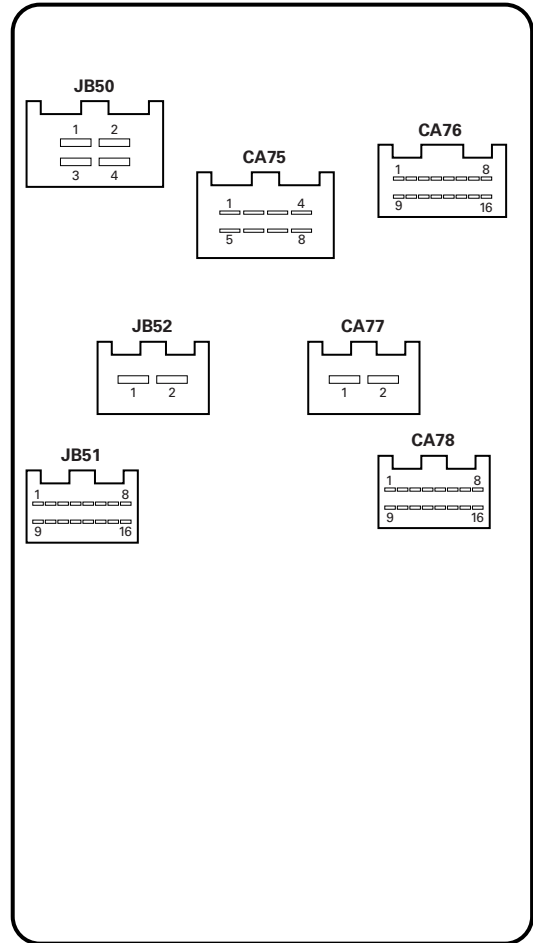

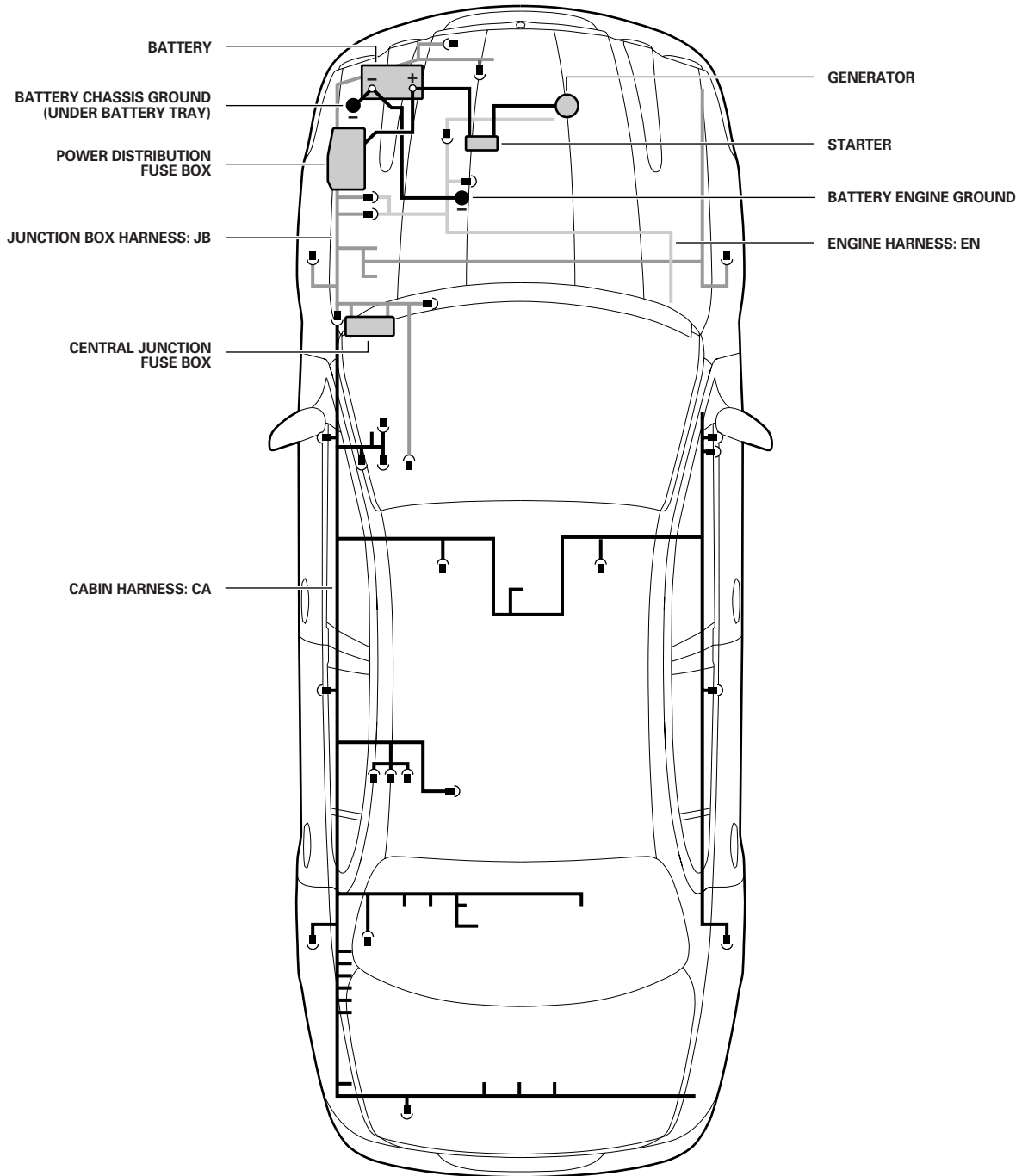

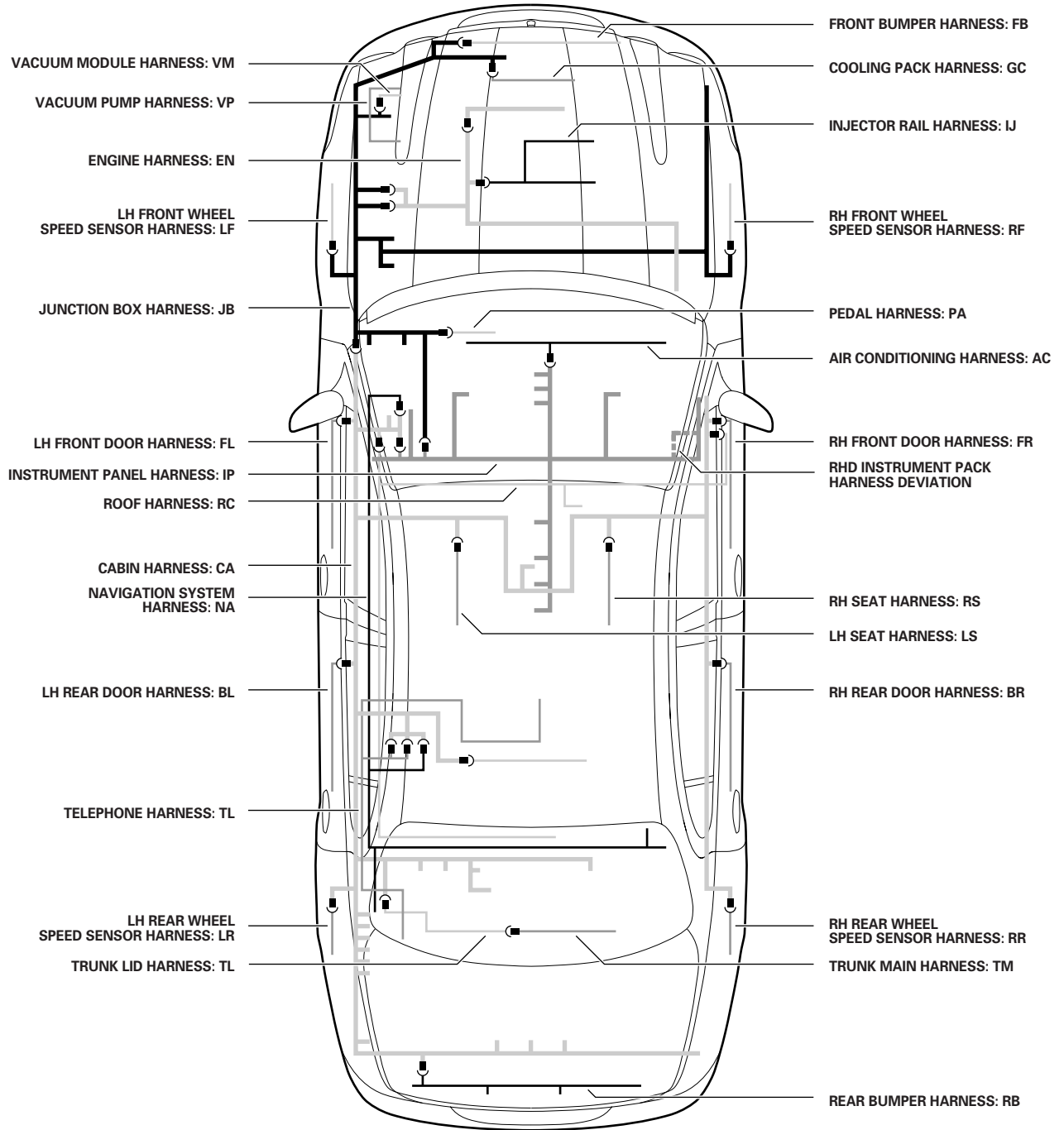

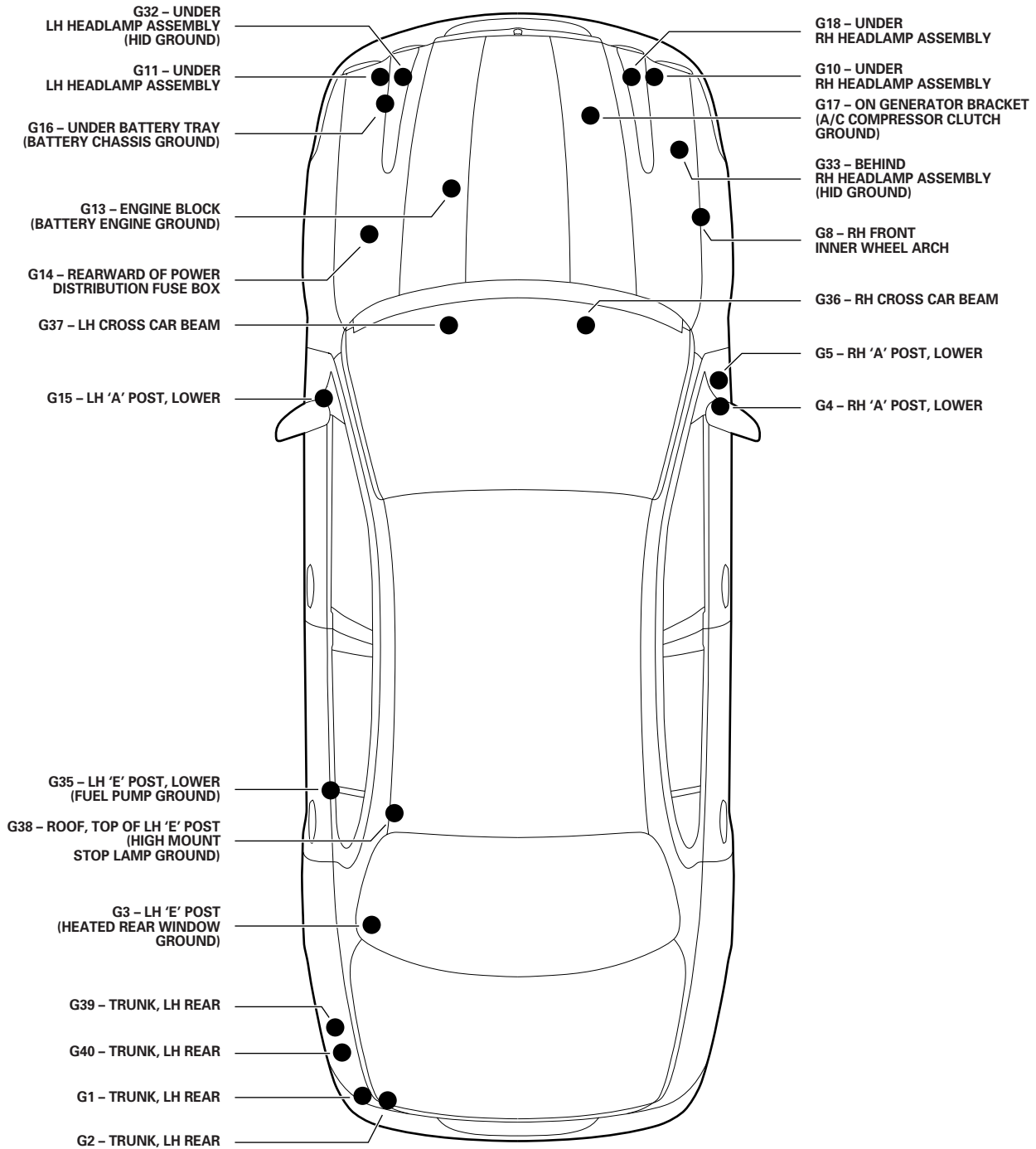

NOTE: UNIQUE GROUND STUDS ARE NOTED IN PARENTHESES.

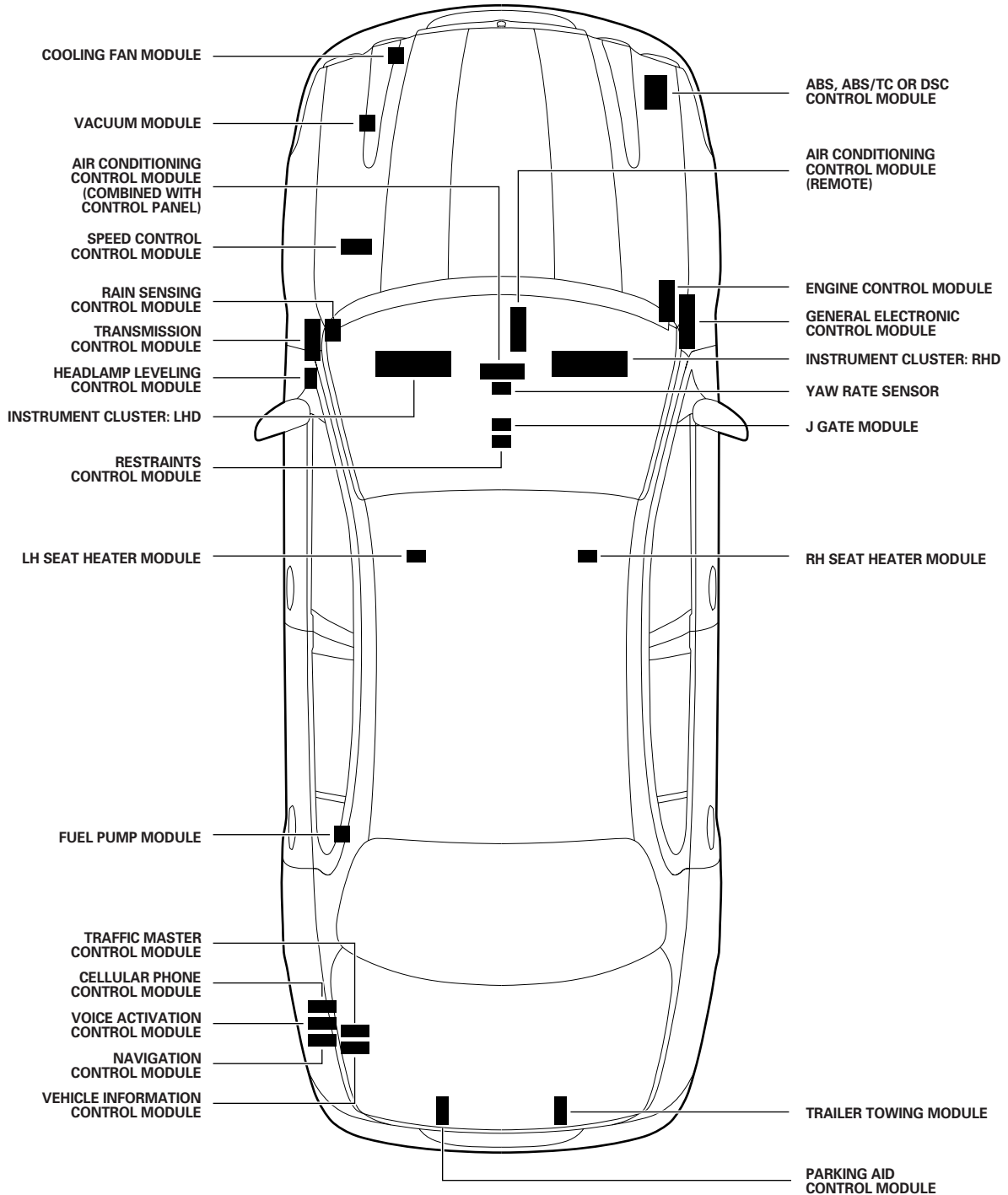



ENGINE CONTROL MODULE: 2.5L & 3.0L

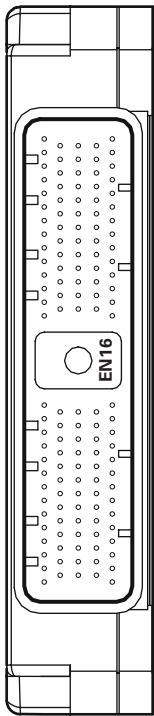

EN16 / 134-WAY / BLACK

107	108	109	110	111	112	113	114	115	116	117	118	119	120	121	122	123	124	125	126	127	128	129	130	131	132	133	134	
Y	P	RW	G	B	—	BG	BO	BO	BG	B	—	BO	BW	BW	WU	—	G	Y	—	—	BW	N	N	BR	YG	YG	BG	RW
81	82	83	84	85	86	87	88	89	90	91	92	93	94	95	96	97	98	99	100	101	102	103	104	105	106	107	108	
B	B	Y	P	—	—	GU	GW	GR	—	B	U	OY	O	B	—	N	N	BG	—	—	R	Y	RG	W	R	—	—	
55	56	57	58	59	60	61	62	63	64	65	66	67	68	69	70	71	72	73	74	75	76	77	78	79	80	81	82	
GO	GO	—	—	—	—	GU	GW	GR	—	OG	OY	U	G	N	Y	—	U	—	—	P	Y	—	Y	Y	U	G	—	
29	30	31	32	33	34	35	36	37	38	39	40	41	42	43	44	45	46	47	48	49	50	51	52	53	54	55	56	
B	B	B	—	WG	BG	—	P	Y	OY	OY	B	GO	—	BG	GW	BW	BW	YR	YU	—	—	—	—	—	—	—	—	
1	2	3	4	5	6	7	8	9	10	11	12	13	14	15	16	17	18	19	20	21	22	23	24	25	26	27	28	
RU	RU	—	B	B	Y	GO	GO	U	GU	—	OY	Y	—	—	B	B	BG	BG	—	—	NR	WG	WG	W	WU	N	—	

ENGINE CONTROL MODULE: 2.0L

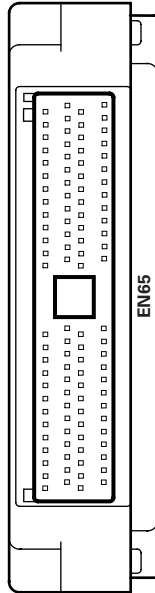

EN65 / 104-WAY / BLACK

79	80	81	82	83	84	85	86	87	88	89	90	91	92	93	94	95	96	97	98	99	100	101	102	103	104
Y	UY	—	—	WG	WG	G	N	G	N	G	Y	—	—	BW	BO	BO	RW	G	R	GR	—	—	B	GO	RU
53	54	55	56	57	58	59	60	61	62	63	64	65	66	67	68	69	70	71	72	73	74	75	76	77	78
N	N	BR	GW	GU	—	O	B	P	Y	GO	B	BG	BO	BG	BO	BO	OY	OY	—	—	—	—	—	—	—
27	28	29	30	31	32	33	34	35	36	37	38	39	40	41	42	43	44	45	46	47	48	49	50	51	52
N	W	BW	GW	BW	—	GO	U	GU	N	BG	W	—	—	GU	GW	GR	RG	WU	—	UY	U	B	—	—	—
1	2	3	4	5	6	7	8	9	10	11	12	13	14	15	16	17	18	19	20	21	22	23	24	25	26
BW	WU	BG	B	B	Y	U	OG	—	—	OY	Y	YG	—	—	GW	GR	G	B	B	B	BG	NR	WG	WG	—

TRANSMISSION CONTROL MODULE

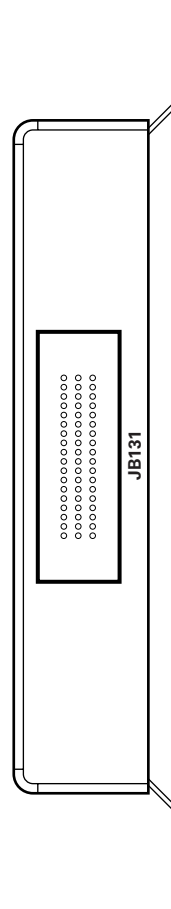

JB131 / 54-WAY / BLUE

18	17	16	15	14	13	12	11	10	9	8	7	6	5	4	3	2	1
R	B	O	N	N	G	G	—	W	B	R	O	UY	N	U	G	—	—
36	35	34	33	32	31	30	29	28	27	26	25	24	23	22	21	20	19
WU	—	Y	Y	—	—	U	—	—	Y	G	W	N	—	N	N	B	—
54	53	52	51	50	49	48	47	46	45	44	43	42	41	40	39	38	37
WU	Y	G	—	—	OY	O	BW	U	—	—	—	Y	—	—	W	B	—



ABS OR ABS/TC CONTROL MODULE

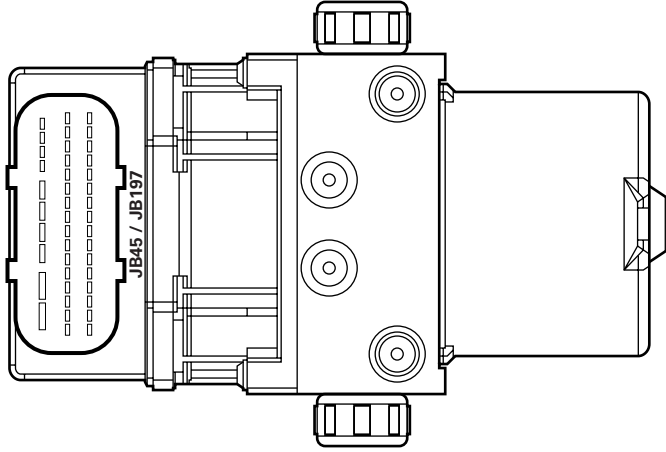

JB45 / 42-WAY / BROWN / ABS CONTROL MODULE

11	12	13	14	15	16	17	18	19	20	21	22	23	24	25	26
—	W	GB	WU	NR	WR	—	—	—	—	—	—	—	GW	Y	—
27	28	29	30	31	32	33	34	35	36	37	38	39	40	41	42
—	N	—	NG	WG	GO	—	—	—	—	—	—	—	—	G	—

JB197 / 42-WAY / BROWN / ABS/TC CONTROL MODULE

11	12	13	14	15	16	17	18	19	20	21	22	23	24	25	26
—	W	GB	WU	NR	WR	—	—	—	—	—	—	—	GW	Y	—
27	28	29	30	31	32	33	34	35	36	37	38	39	40	41	42
B	N	—	NG	WG	GO	—	—	—	—	—	—	—	—	G	—

DSC CONTROL MODULE

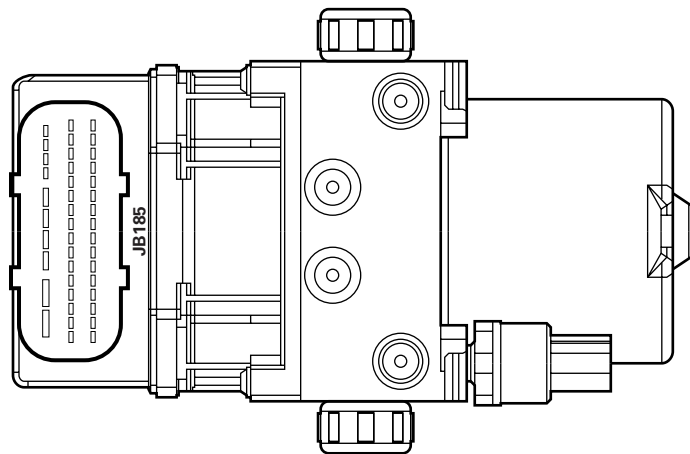

JB185 / 42-WAY / BLUE

11	12	13	14	15	16	17	18	19	20	21	22	23	24	25	26
—	W	GB	WU	NR	WR	—	—	—	—	U*	—	—	GW	Y	B
27	28	29	30	31	32	33	34	35	36	37	38	39	40	41	42
B	N	—	NG	WG	GO	—	—	—	—	—	—	GW	G	—	GB

* B – early production vehicles.



AIR CONDITIONING CONTROL MODULE (REMOTE)

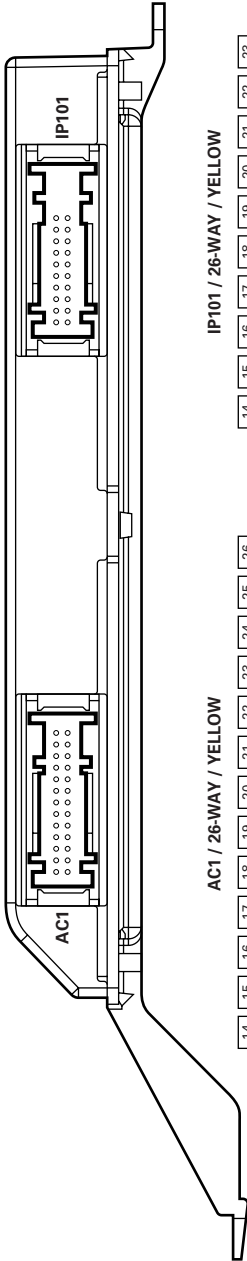

AC1 / 26-WAY / YELLOW

14	G
15	UY
16	B
17	—
18	—
19	—
20	—
21	GU
22	GB
23	OG
24	RW
25	RG
26	OY
1	—
2	—
3	—
4	GW
5	U
6	GR
7	GO
8	RU
9	R
10	WB
11	W
12	Y
13	R

IP101 / 26-WAY / YELLOW

14	U
15	B
16	W
17	B
18	B
19	B
20	O
21	W
22	Y
23	G
1	OY
2	WR
3	B
4	B
5	BW
6	B
7	BW
8	—
9	Y
10	G

AIR CONDITIONING CONTROL MODULE (AUTOMATIC, PANEL)

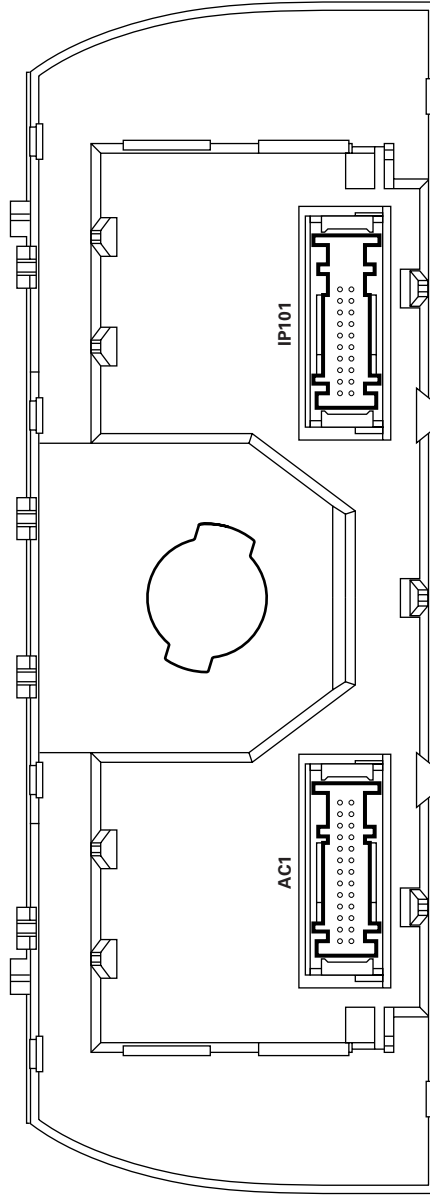

AC1 / 26-WAY / YELLOW

14	G
15	UY
16	B
17	—
18	—
19	—
20	—
21	GU
22	GB
23	OG
24	RW
25	RG
26	OY
1	—
2	—
3	—
4	GW
5	U
6	GR
7	GO
8	RU
9	R
10	WB
11	W
12	Y
13	R

IP101 / 26-WAY / YELLOW

14	U
15	B
16	W
17	B
18	B
19	B
20	O
21	W
22	Y
23	G
1	OY
2	WR
3	B
4	B
5	BW
6	B
7	BW
8	—
9	Y
10	G



AIR CONDITIONING CONTROL MODULE (MANUAL, PANEL)

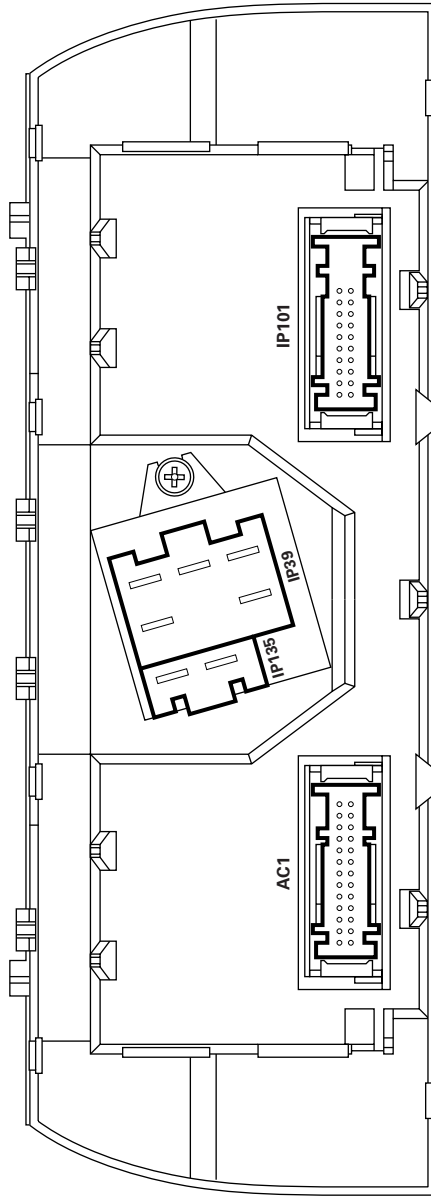

IP101 / 26-WAY / YELLOW

14	G	15	U	16	B	17	—	18	—	19	—	20	O	21	—	22	Y	23	G
1	—	2	OY	3	B	4	B	5	—	6	BW	7	—	8	—	9	Y	10	—

IP39 / 6-WAY / GREY

1	GB	2	BO	3	BR
4	BK	5	—	6	BG

IP135 / 2-WAY / GREEN

1	BW
2	B

AC1 / 26-WAY / YELLOW

14	G	15	UY	16	B	17	—	18	—	19	—	20	GU	21	GB	22	OG	23	O	24	RW	25	RG	26	OY
1	—	2	—	3	—	4	GW	5	U	6	GR	7	GO	8	RU	9	R	10	WB	11	W	12	Y	13	R



GENERAL ELECTRONIC CONTROL MODULE

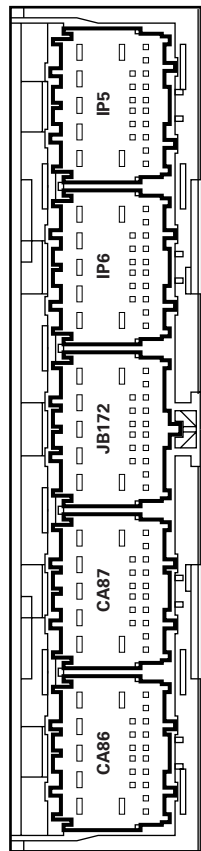

CA86 / 23-WAY / GREY

1	OG	2	OY	3	BK	4	YB	5	B	6	—	7	—	8	—	9	—	10	—	11	—	12	—	13	—	14	—	15	—	16	G	17	G	18	Y	19	O	20	Y	21	—	22	N	23	W
---	----	---	----	---	----	---	----	---	---	---	---	---	---	---	---	---	---	----	---	----	---	----	---	----	---	----	---	----	---	----	---	----	---	----	---	----	---	----	---	----	---	----	---	----	---

IP5 / 23-WAY / BROWN

1*	WB	2	—	3	B	4	GU	5*	WG	6	—	7	—	8	—	9	—	10	—	11	—	12	—	13	—	14	B	15	—	16	U	17	—	18	U	19	Y	20	B	21	WG	22	OY	23	—
----	----	---	---	---	---	---	----	----	----	---	---	---	---	---	---	---	---	----	---	----	---	----	---	----	---	----	---	----	---	----	---	----	---	----	---	----	---	----	---	----	----	----	----	----	---

* NOTE: LHD shown. RHD vehicles: Pin 1 – WG, Pin 5 – WB.

CA87 / 23-WAY / GREEN

1	B	2	O	3	YB	4	O	5	WB	6	—	7	—	8	—	9	—	10	—	11	—	12	—	13	—	14	—	15	Y	16	W	17	WG	18	—	19	—	20	—	21	—	22	—	23	—
---	---	---	---	---	----	---	---	---	----	---	---	---	---	---	---	---	---	----	---	----	---	----	---	----	---	----	---	----	---	----	---	----	----	----	---	----	---	----	---	----	---	----	---	----	---

JB172 / 23-WAY / BLUE

1	OY	2	WB	3	O	4	OY	5	O	6	—	7	—	8	—	9	—	10	—	11	—	12	—	13	—	14	—	15	—	16	—	17	—	18	—	19	—	20	—	21	—	22	—	23	—
---	----	---	----	---	---	---	----	---	---	---	---	---	---	---	---	---	---	----	---	----	---	----	---	----	---	----	---	----	---	----	---	----	---	----	---	----	---	----	---	----	---	----	---	----	---

IP6 / 23-WAY / WHITE

1	B	2	—	3	—	4	W	5	GR	6	—	7	—	8	B	9	G	10	R	11	BM	12	—	13	—	14	—	15	Y	16	—	17	—	18	—	19	—	20	—	21	—	22	—	23	—
---	---	---	---	---	---	---	---	---	----	---	---	---	---	---	---	---	---	----	---	----	----	----	---	----	---	----	---	----	---	----	---	----	---	----	---	----	---	----	---	----	---	----	---	----	---



INSTRUMENT CLUSTER

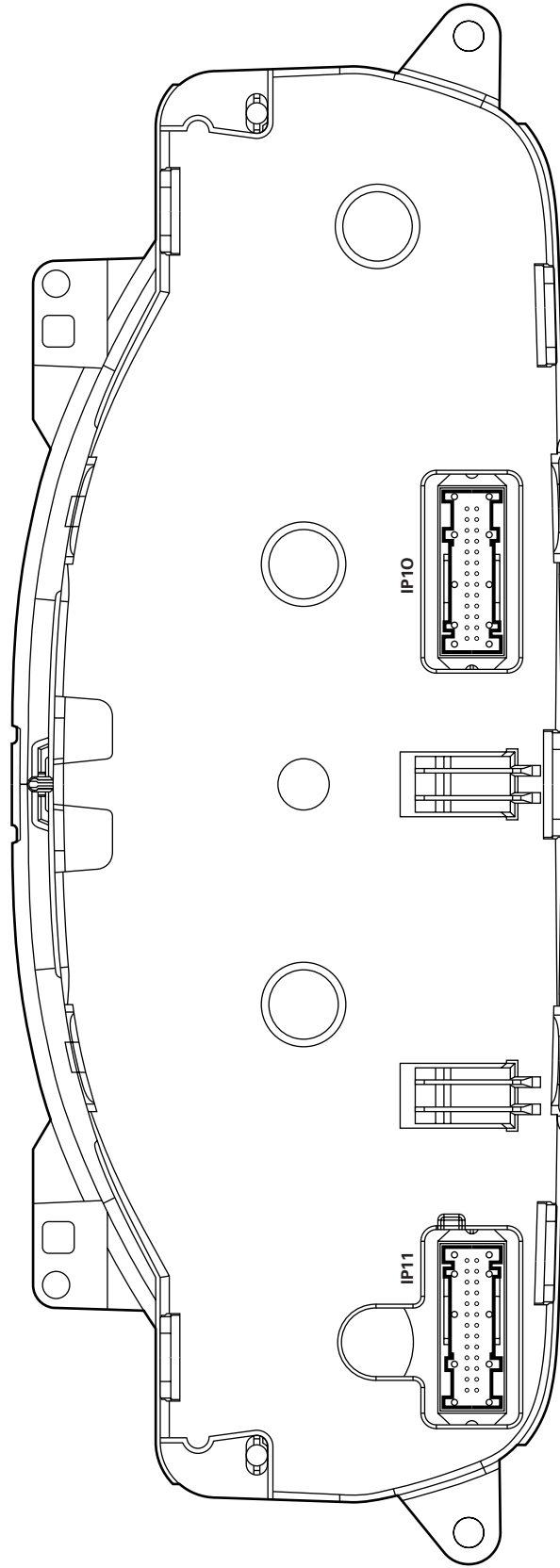

IP10 / 26-WAY / YELLOW

14	15	16	17	18	19	20	21	22	23	24	25	26
—	B	B	Y	G	U	WU	—	Y	U	Y	W	—
1	2	3	4	5	6	7	8	9	10	11	12	13
GB	OY	WG	O	B	G	WU	WB	B	U	B	B	—

IP11 / 26-WAY / YELLOW

13	12	11	10	9	8	7	6	5	4	3	2	1
YU	—	GR	—	—	B	O	—	B	—	GB	—	—
26	25	24	23	22	21	20	19	18	17	16	15	14
—	R	GR	U	—	O	—	U	—	OY	—	OG	—

Fig. 01.1**COMPONENTS**

Component	Connector(s)	Connector Description	Location
BATTERY	—	—	ENGINE COMPARTMENT
CENTRAL JUNCTION FUSE BOX	CA75	8-WAY / GREY	PASSENGER COMPARTMENT, FRONT BULKHEAD LH SIDE
	CA76	16-WAY / GREEN	
	CA77	2-WAY / GREY	
	CA78	16-WAY / GREY	
	IP1	14-WAY / GREEN	
	IP2	16-WAY GREY	
	IP3	2-WAY / GREY	
	IP4	14-WAY / GREY	
	JB50	4-WAY / GREY	
	JB51	16-WAY / BLUE	
	JB52	2-WAY / BLACK	
IGNITION SWITCH	IP18	7-WAY / BLACK	STEERING COLUMN
INERTIA SWITCH	IP132	3-WAY / BLACK	LOWER RH A POST
POWER DISTRIBUTION FUSE BOX	—	—	ENGINE COMPARTMENT LH SIDE
TRANSIT ISOLATION DEVICE	JB186	2-WAY / BLACK	BATTERY

HARNESS IN-LINE CONNECTORS

Connector	Connector Description	Location
JB3	14-WAY / BLUE / JUNCTION BOX HARNESS TO INSTRUMENT PANEL HARNESS	BELOW INSTRUMENT PANEL LH SIDE
JB130	22-WAY / GREEN / JUNCTION BOX HARNESS TO INSTRUMENT PANEL HARNESS	ADJACENT TO CENTRAL JUNCTION FUSE BOX

GROUNDS

Ground	Location
G13	ENGINE COMPARTMENT / UNDER BATTERY TRAY
G16	ENGINE COMPARTMENT / ENGINE BLOCK

Refer to the front of this book for detailed information and illustrations regarding the location and identification of harnesses, relays, fuses, grounds, control modules and control module pins.

COMPONENTS

Component	Connector(s)	Connector Description	Location
CENTRAL JUNCTION FUSE BOX	CA75	8-WAY / GREY	PASSENGER COMPARTMENT, FRONT BULKHEAD LH SIDE
	CA76	16-WAY / GREEN	
	CA77	2-WAY / GREY	
	CA78	16-WAY / GREY	
	IP1	14-WAY / GREEN	
	IP2	16-WAY / GREY	
	IP3	2-WAY / GREY	
	IP4	14-WAY / GREY	
	JB50	4-WAY / GREY	
	JB51	16-WAY / BLUE	
	JB52	2-WAY / BLACK	
POWER DISTRIBUTION FUSE BOX	—	—	ENGINE COMPARTMENT LH SIDE

HARNESS IN-LINE CONNECTORS

Connector	Connector Description	Location
CA10	22-WAY / GREY / ENGINE HARNESS TO CABIN HARNESS	BELOW THE GLOVEBOX
CA20	20-WAY / BLACK / DOOR HARNESS TO CABIN HARNESS	DRIVER SIDE A POST
CA25	14-WAY / NATURAL / REAR DOOR HARNESS TO CABIN HARNESS	LH B/C POST
CA30	14-WAY / NATURAL / DOOR LOCK LINK LEAD	RH B/C POST
CA36	16-WAY / GREEN / CABIN HARNESS TO ROOF HARNESS	LH LOWER A POST
CA65	18-WAY / BLACK / CABIN HARNESS TO SEAT HARNESS	BELOW RH FRONT SEAT
CA70	18-WAY / BLACK / CABIN HARNESS TO SEAT HARNESS	BELOW LH FRONT SEAT
CA169	4-WAY / GREY / CABIN HARNESS TO INSTRUMENT PANEL HARNESS	BELOW THE GLOVEBOX
CA407	16-WAY / GREEN / TELEPHONE HARNESS TO CABIN HARNESS	BELOW LH REAR SEAT CUSHION
CA414	16-WAY / BLUE / TELEPHONE HARNESS TO CABIN HARNESS	BELOW LH REAR SEAT CUSHION
JB1	42-WAY / BLACK / JUNCTION BOX HARNESS TO ENGINE HARNESS	ADJACENT TO LH SUSPENSION TURRET
JB3	14-WAY / BLUE / JUNCTION BOX HARNESS TO INSTRUMENT PANEL HARNESS	BELOW INSTRUMENT PANEL LH SIDE
JB129	22-WAY / GREY / INSTRUMENT PANEL HARNESS TO JUNCTION BOX HARNESS	LH LOWER A POST
JB188	2-WAY / BLACK / JUNCTION BOX HARNESS TO COOLING FAN MODULE LINK LEAD	ADJACENT TO RADIATOR LH SIDE

Refer to the front of this book for detailed information and illustrations regarding the location and identification of harnesses, relays, fuses, grounds, control modules and control module pins.

COMPONENTS

Component	Connector(s)	Connector Description	Location	
ACCESSORY POWER RELAY	—	—	POWER DISTRIBUTION FUSE BOX R4	
CENTRAL JUNCTION FUSE BOX	CA75	8-WAY / GREY	PASSENGER COMPARTMENT, FRONT BULKHEAD LH SIDE	
	CA76	16-WAY / GREEN		
	CA77	2-WAY / GREY		
	CA78	16-WAY / GREY		
	IP1	14-WAY / GREEN		
	IP2	16-WAY / GREY		
	IP3	2-WAY / GREY		
	IP4	14-WAY / GREY		
	JB50	4-WAY / GREY		
	JB51	16-WAY / BLUE		
	JB52	2-WAY / BLACK		
IGNITION SWITCH	IP18	7-WAY / BLACK		STEERING COLUMN
POWER DISTRIBUTION FUSE BOX	—	—		ENGINE COMPARTMENT LH SIDE

HARNESS IN-LINE CONNECTORS

Connector	Connector Description	Location
CA129	12-WAY / GREY / CABIN HARNESS TO REAR BUMPER HARNESS	SPARE WHEEL WELL
CA170	16-WAY / GREEN / IN-LINE CONNECTOR	LH LOWER A POST
CA230	16-WAY / BLUE / CABIN HARNESS TO INSTRUMENT PANEL HARNESS	LH LOWER A POST
CA240	12-WAY / GREY / CABIN HARNESS TO INSTRUMENT PANEL HARNESS	LH LOWER A POST
CA241	22-WAY / GREEN / INSTRUMENT PANEL HARNESS TO CABIN HARNESS	ADJACENT TO CENTRAL JUNCTION FUSE BOX
CA407	16-WAY / GREEN / TELEPHONE HARNESS TO CABIN HARNESS	BELOW LH REAR SEAT CUSHION
CA414	16-WAY / BLUE / TELEPHONE HARNESS TO CABIN HARNESS	BELOW LH REAR SEAT CUSHION
JB129	22-WAY / GREY / INSTRUMENT PANEL HARNESS TO JUNCTION BOX HARNESS	LH LOWER A POST

GROUNDS

Ground	Location
G14	ENGINE COMPARTMENT / REARWARD OF POWER DISTRIBUTION FUSE BOX

Refer to the front of this book for detailed information and illustrations regarding the location and identification of harnesses, relays, fuses, grounds, control modules and control module pins.

COMPONENTS

Component	Connector(s)	Connector Description	Location
CENTRAL JUNCTION FUSE BOX	CA75 CA76 CA77 CA78 IP1 IP2 IP3 IP4 JB50 JB51 JB52	8-WAY / GREY 16-WAY / GREEN 2-WAY / GREY 16-WAY / GREY 14-WAY / GREEN 16-WAY / GREY 2-WAY / GREY 14-WAY / GREY 4-WAY / GREY 16-WAY / BLUE 2-WAY / BLACK	PASSENGER COMPARTMENT, FRONT BULKHEAD LH SIDE
IGNITION RELAY	—	—	CENTRAL JUNCTION FUSE BOX R18
IGNITION SWITCH	IP18	7-WAY / BLACK	STEERING COLUMN
INERTIA SWITCH	IP132	3-WAY / BLACK	LOWER RH A POST

HARNESS IN-LINE CONNECTORS

Connector	Connector Description	Location
CA1	22-WAY / NATURAL / CABIN HARNESS TO INSTRUMENT PANEL HARNESS	LH LOWER A POST
CA10	22-WAY / GREY / ENGINE HARNESS TO CABIN HARNESS	BELOW THE GLOVEBOX
CA15	20-WAY / BLACK / DOOR HARNESS TO CABIN HARNESS	DRIVER SIDE A POST
CA20	20-WAY / BLACK / DOOR HARNESS TO CABIN HARNESS	DRIVER SIDE A POST
CA30	14-WAY / NATURAL / DOOR LOCK LINK LEAD	RH B/C POST
CA36	16-WAY / GREEN / CABIN HARNESS TO ROOF HARNESS	LH LOWER A POST
CA65	18-WAY / BLACK / CABIN HARNESS TO SEAT HARNESS	BELOW RH FRONT SEAT
CA70	18-WAY / BLACK / CABIN HARNESS TO SEAT HARNESS	BELOW LH FRONT SEAT
CA170	16-WAY / GREEN / IN-LINE CONNECTOR	LH LOWER A POST
CA230	16-WAY / BLUE / CABIN HARNESS TO INSTRUMENT PANEL HARNESS	LH LOWER A POST
CA240	12-WAY / GREY / CABIN HARNESS TO INSTRUMENT PANEL HARNESS	LH LOWER A POST
CA407	16-WAY / GREEN / TELEPHONE HARNESS TO CABIN HARNESS	BELOW LH REAR SEAT CUSHION
JB1	42-WAY / BLACK / JUNCTION BOX HARNESS TO ENGINE HARNESS	ADJACENT TO LH SUSPENSION TURRET
JB2	16-WAY / GREEN / JUNCTION BOX HARNESS TO CABIN HARNESS	ADJACENT TO CENTRAL JUNCTION FUSE BOX
JB3	14-WAY / BLUE / JUNCTION BOX HARNESS TO INSTRUMENT PANEL HARNESS	BELOW INSTRUMENT PANEL LH SIDE
JB129	22-WAY / GREY / INSTRUMENT PANEL HARNESS TO JUNCTION BOX HARNESS	LH LOWER A POST
JB130	22-WAY / GREEN / JUNCTION BOX HARNESS TO INSTRUMENT PANEL HARNESS	ADJACENT TO CENTRAL JUNCTION FUSE BOX

GROUND

Ground	Location
G15	PASSENGER COMPARTMENT / LH LOWER A POST

Refer to the front of this book for detailed information and illustrations regarding the location and identification of harnesses, relays, fuses, grounds, control modules and control module pins.

Fig. 01.5

General Electronic Control Module

Pin	Description and Characteristic
PG	CA86-5 POWER GROUND: GROUND
O	IP5-20 BATTERY SAVER RELAY DRIVE: TO ACTIVATE, GECM SWITCHES CIRCUIT TO GROUND
SG	IP6-1 LOGIC GROUND: GROUND
B+	JB172-5 BATTERY POWER SUPPLY (TURN SIGNALS): B+

COMPONENTS

Component	Connector(s)	Connector Description	Location	
BATTERY SAVER RELAY	—	—	CENTRAL JUNCTION FUSE BOX R21	
CENTRAL JUNCTION FUSE BOX	CA75	8-WAY / GREY	PASSENGER COMPARTMENT, FRONT BULKHEAD LH SIDE	
	CA76	16-WAY / GREEN		
	CA77	2-WAY / GREY		
	CA78	16-WAY / GREY		
	IP1	14-WAY / GREEN		
	IP2	16-WAY / GREY		
	IP3	2-WAY / GREY		
	IP4	14-WAY / GREY		
	JB50	4-WAY / GREY		
	JB51	16-WAY / BLUE		
	JB52	2-WAY / BLACK		
GENERAL ELECTRONIC CONTROL MODULE	CA86	23-WAY / GREY		BEHIND INSTRUMENT PANEL RH SIDE
	CA87	23-WAY / GREEN		
	IP5	23-WAY / BROWN		
	IP6	23-WAY / WHITE		
	JB172	23-WAY / BLUE		

HARNESS IN-LINE CONNECTORS

Connector	Connector Description	Location
CA16	20-WAY / BLACK / DOOR HARNESS TO CABIN HARNESS	DRIVER SIDE A POST
CA21	20-WAY / BLACK / DOOR HARNESS TO CABIN HARNESS	DRIVER SIDE A POST
CA36	16-WAY / GREEN / CABIN HARNESS TO ROOF HARNESS	LH LOWER A POST

GROUND

Ground	Location
G4	PASSENGER COMPARTMENT / RH LOWER A POST
G5	PASSENGER COMPARTMENT / RH LOWER A POST

FOR CONTROL MODULE PIN-OUT INFORMATION, UNFOLD PAGE TO LEFT.

The following abbreviations are used to represent values for Control Module Pin-Out data

I	Input	PG	Power Ground	CAN	CAN Network	D	Serial and Encoded Data
O	Output	SS	Sensor / Signal Supply V	SCP	SCP Network	V	Voltage (DC)
B+	Battery Voltage	SG	Sensor / Signal Ground	D2	D2B Network	PWM	Pulse Width Modulated

CAUTION: The information on this data page is furnished to aid the user in understanding circuit operation. THIS INFORMATION SHOULD BE USED FOR REFERENCE ONLY.

NOTE: The characteristics listed are approximately those that can be expected at the control module connector pins with all circuit connections made and all components connected and fitted.

Refer to the front of this book for detailed information and illustrations regarding the location and identification of harnesses, relays, fuses, grounds, control modules and control module pins.

Fig. 01.6**COMPONENTS**

Component	Connector(s)	Connector Description	Location
EMS CONTROL RELAY	—	—	POWER DISTRIBUTION FUSE BOX R7
POWER DISTRIBUTION FUSE BOX	—	—	ENGINE COMPARTMENT LH SIDE

HARNESS IN-LINE CONNECTORS

Connector	Connector Description	Location
CA5	12-WAY / BLACK / CABIN HARNESS TO FUEL TANK LINK LEAD	TOP OF FUEL TANK
CA10	22-WAY / GREY / ENGINE HARNESS TO CABIN HARNESS	BELOW THE GLOVEBOX
EN4	12-WAY / BLACK / ENGINE HARNESS TO INJECTOR RAIL HARNESS	ADJACENT TO THE TRANSMISSION BELL HOUSING
JB1	42-WAY / BLACK / JUNCTION BOX HARNESS TO ENGINE HARNESS	ADJACENT TO LH SUSPENSION TURRET
JB187	2-WAY / BLACK / JUNCTION BOX HARNESS TO COOLING FAN MODULE LINK LEAD	ADJACENT TO RADIATOR LH SIDE

Refer to the front of this book for detailed information and illustrations regarding the location and identification of harnesses, relays, fuses, grounds, control modules and control module pins.

CONTROL MODULE PIN-OUT INFORMATION

General Electronic Control Module

Pin	Description and Characteristic
S IP5-18	SCP -
S IP5-19	SCP +
I IP6-8	KEY-IN IGNITION SWITCH: B+ WHEN KEY IN

Instrument Cluster

Pin	Description and Characteristic
D IP10-3	PATS 1: ENCODED COMMUNICATION
D IP10-4	PATS 2: ENCODED COMMUNICATION
I IP10-5	PATS GROUND: GROUND
O IP10-6	PATS TRANSCIEVER POWER: B+
C IP10-17	CAN +
C IP10-18	CAN -
S IP10-22	SCP +
S IP10-23	SCP -
I IP11-7	BATTERY POWER SUPPLY: B+
I IP11-8	POWER GROUND: GROUND
I IP11-11	IGNITION SWITCHED POWER SUPPLY (II): B+

Engine Control Module (2.5L & 3.0L)

Pin	Description and Characteristic
I EN16-006	ENGINE CRANK: B+
I EN16-031	PARK / NEUTRAL SWITCH (AUTOMATIC TRANSMISSION): NORMALLY CLOSED / GROUND WHEN ACTIVATED
I EN16-031	CLUTCH PEDAL SAFETY SWITCH (MANUAL TRANSMISSION): NORMALLY OPEN / B+ WHEN ACTIVATED
O EN16-041	STARTER RELAY DRIVE: TO ACTIVATE, ECM SWITCHES CIRCUIT TO GROUND
I EN16-053	GENERATOR CHARGE: VARIABLE VOLTAGE
O EN16-065	GENERATOR FIELD RETURN SIGNAL: VARIABLE VOLTAGE BY GENERATOR OPERATING CONDITION
I EN16-079	GENERATOR LOAD: B+ = NORMAL, AFTER-START SWITCH-ON; GROUND = GENERATOR FAILURE, AFTER-START SWITCH-ON
C EN16-123	CAN -
C EN16-124	CAN +

NOTE: Refer to the Appendix at the rear of this book for Network Messages.

The following abbreviations are used to represent values for Control Module Pin-Out data

I	Input	PG	Power Ground	CAN	CAN Network	D	Serial and Encoded Data
O	Output	SS	Sensor / Signal Supply V	SCP	SCP Network	V	Voltage (DC)
B+	Battery Voltage	SG	Sensor / Signal Ground	D2	D2B Network	PWM	Pulse Width Modulated

CAUTION: The information on this data page is furnished to aid the user in understanding circuit operation. THIS INFORMATION SHOULD BE USED FOR REFERENCE ONLY.

NOTE: The characteristics listed are approximately those that can be expected at the control module connector pins with all circuit connections made and all components connected and fitted.

Fig. 02.1

COMPONENTS

Component	Connector(s)	Connector Description	Location
BATTERY	—	—	ENGINE COMPARTMENT
CLUTCH PEDAL SAFETY SWITCH	PA5	2-WAY / BLACK	TOP OF CLUTCH PEDAL
ENGINE CONTROL MODULE (2.5L & 3.0L)	EN16	134-WAY / BLACK	ENGINE COMPARTMENT, FRONT BULKHEAD RH SIDE
GENERAL ELECTRONIC CONTROL MODULE	CA86 CA87 IP5 IP6 JB172	23-WAY / GREY 23-WAY / GREEN 23-WAY / BROWN 23-WAY / WHITE 23-WAY / BLUE	BEHIND INSTRUMENT PANEL RH SIDE
GENERATOR	EN49	4-WAY / BLACK	ENGINE BANK 1, FRONT
IGNITION SWITCH	IP18	7-WAY / BLACK	STEERING COLUMN
INSTRUMENT CLUSTER	IP10 IP11	26-WAY / YELLOW 26-WAY / YELLOW	INSTRUMENT PANEL
PASSIVE ANTI-THEFT SYSTEM TRANSCIEVER	IP15	4-WAY / GREEN	STEERING COLUMN, IGNITION SWITCH
POWER DISTRIBUTION FUSE BOX	—	—	ENGINE COMPARTMENT LH SIDE
STARTER MOTOR	ST2 ST3 / EN700	1-WAY EYELET 1-WAY EYELET	ENGINE BLOCK RH SIDE
STARTER RELAY	—	—	POWER DISTRIBUTION FUSE BOX R10
TRANSMISSION RANGE SENSOR	JB156	10-WAY / BLACK	TOP OF TRANSMISSION

HARNESS IN-LINE CONNECTORS

Connector	Connector Description	Location
EN700	1-WAY / JUNCTION BOX HARNESS TO ENGINE HARNESS	STARTER SOLENOID
JB1	42-WAY / BLACK / JUNCTION BOX HARNESS TO ENGINE HARNESS	ADJACENT TO LH SUSPENSION TURRET
JB2	16-WAY / GREEN / JUNCTION BOX HARNESS TO CABIN HARNESS	ADJACENT TO CENTRAL JUNCTION FUSE BOX
JB129	22-WAY / GREY / INSTRUMENT PANEL HARNESS TO JUNCTION BOX HARNESS	LH LOWER A POST
JB145	8-WAY / BLACK / ENGINE HARNESS TO JUNCTION BOX HARNESS	ADJACENT TO CENTRAL JUNCTION FUSE BOX

GROUNDINGS

Ground	Location
G13	ENGINE COMPARTMENT / ENGINE BLOCK
G16	ENGINE COMPARTMENT / UNDER BATTERY TRAY
G37	PASSENGER COMPARTMENT / LH CROSS CAR BEAM

FOR CONTROL MODULE PIN-OUT INFORMATION, UNFOLD PAGE TO LEFT.

Refer to the front of this book for detailed information and illustrations regarding the location and identification of harnesses, relays, fuses, grounds, control modules and control module pins.

CONTROL MODULE PIN-OUT INFORMATION

General Electronic Control Module

Pin	Description and Characteristic
S IP5-18	SCP -
S IP5-19	SCP +
I IP6-8	KEY-IN IGNITION SWITCH: B+ WHEN KEY IN

Instrument Cluster

Pin	Description and Characteristic
D IP10-3	PATS 1: ENCODED COMMUNICATION
D IP10-4	PATS 2: ENCODED COMMUNICATION
I IP10-5	PATS GROUND: GROUND
O IP10-6	PATS TRANSCIEVER POWER: B+
C IP10-17	CAN +
C IP10-18	CAN -
S IP10-22	SCP +
S IP10-23	SCP -
I IP11-7	BATTERY POWER SUPPLY: B+
I IP11-8	POWER GROUND: GROUND
I IP11-11	IGNITION SWITCHED POWER SUPPLY (II): B+

Engine Control Module (2.0L)

Pin	Description and Characteristic
I EN65-006	ENGINE CRANK: B+
O EN65-008	GENERATOR FIELD RETURN SIGNAL: VARIABLE VOLTAGE BY GENERATOR OPERATING CONDITION
I EN65-035	GENERATOR LOAD: B+ = NORMAL, AFTER-START SWITCH-ON; GROUND = GENERATOR FAILURE, AFTER-START SWITCH-ON
I EN65-043	GENERATOR CHARGE: VARIABLE VOLTAGE
O EN65-068	STARTER RELAY DRIVE: TO ACTIVATE, ECM SWITCHES CIRCUIT TO GROUND
I EN65-085	PARK / NEUTRAL SWITCH (AUTOMATIC TRANSMISSION): NORMALLY CLOSED / GROUND WHEN ACTIVATED
I EN65-085	CLUTCH SAFETY CIRCUIT (MANUAL TRANSMISSION): B+
C EN65-088	CAN -
C EN65-089	CAN +

NOTE: Refer to the Appendix at the rear of this book for Network Messages.

The following abbreviations are used to represent values for Control Module Pin-Out data

I	Input	PG	Power Ground	CAN	CAN Network	D	Serial and Encoded Data
O	Output	SS	Sensor / Signal Supply V	SCP	SCP Network	V	Voltage (DC)
B+	Battery Voltage	SG	Sensor / Signal Ground	D2	D2B Network	PWM	Pulse Width Modulated

CAUTION: The information on this data page is furnished to aid the user in understanding circuit operation. THIS INFORMATION SHOULD BE USED FOR REFERENCE ONLY.

NOTE: The characteristics listed are approximately those that can be expected at the control module connector pins with all circuit connections made and all components connected and fitted.

Fig. 02.2

COMPONENTS

Component	Connector(s)	Connector Description	Location
BATTERY	—	—	ENGINE COMPARTMENT
ENGINE CONTROL MODULE (2.0L)	EN16	134-WAY / BLACK	ENGINE COMPARTMENT, FRONT BULKHEAD RH SIDE
GENERAL ELECTRONIC CONTROL MODULE	CA86 CA87 IP5 IP6 JB172	23-WAY / GREY 23-WAY / GREEN 23-WAY / BROWN 23-WAY / WHITE 23-WAY / BLUE	BEHIND INSTRUMENT PANEL RH SIDE
GENERATOR	EN49	4-WAY / BLACK	ENGINE BANK 1, FRONT
IGNITION SWITCH	IP18	7-WAY / BLACK	STEERING COLUMN
INSTRUMENT CLUSTER	IP10 IP11	26-WAY / YELLOW 26-WAY / YELLOW	INSTRUMENT PANEL
PASSIVE ANTI-THEFT SYSTEM TRANSCIEVER	IP15	4-WAY / GREEN	STEERING COLUMN, IGNITION SWITCH
POWER DISTRIBUTION FUSE BOX	—	—	ENGINE COMPARTMENT LH SIDE
STARTER MOTOR (EARLY PRODUCTION)	ST2 ST3 / EN700	1-WAY EYELET 1-WAY EYELET	ENGINE BLOCK RH SIDE
STARTER RELAY	—	—	POWER DISTRIBUTION FUSE BOX R10
TRANSMISSION RANGE SENSOR	JB156	10-WAY / BLACK	TOP OF TRANSMISSION

HARNESS IN-LINE CONNECTORS

Connector	Connector Description	Location
EN700	1-WAY / JUNCTION BOX HARNESS TO ENGINE HARNESS	STARTER SOLENOID
JB1	42-WAY / BLACK / JUNCTION BOX HARNESS TO ENGINE HARNESS	ADJACENT TO LH SUSPENSION TURRET
JB129	22-WAY / GREY / INSTRUMENT PANEL HARNESS TO JUNCTION BOX HARNESS	LH LOWER A POST
JB145	8-WAY / BLACK / ENGINE HARNESS TO JUNCTION BOX HARNESS	ADJACENT TO CENTRAL JUNCTION FUSE BOX
JB196	10-WAY / GREY / JUNCTION BOX HARNESS TO CABIN HARNESS	ADJACENT TO FOOT PEDALS

GROUND

Ground	Location
G13	ENGINE COMPARTMENT / ENGINE BLOCK
G16	ENGINE COMPARTMENT / UNDER BATTERY TRAY
G37	PASSENGER COMPARTMENT / LH CROSS CAR BEAM

FOR CONTROL MODULE PIN-OUT INFORMATION, UNFOLD PAGE TO LEFT.

Refer to the front of this book for detailed information and illustrations regarding the location and identification of harnesses, relays, fuses, grounds, control modules and control module pins.

CONTROL MODULE PIN-OUT INFORMATION

Engine Control Module (2.5L & 3.0L)

Pin	Description and Characteristic
O EN16-001	HO2 SENSOR HEATER CONTROL – 1/1: PWM, 1 CYCLE PER 128 ms, VARIABLE DUTY CYCLE
O EN16-002	HO2 SENSOR HEATER CONTROL – 1/1: PWM, 1 CYCLE PER 128 ms, VARIABLE DUTY CYCLE
PG EN16-004	POWER GROUND 1: GROUND
PG EN16-005	POWER GROUND 2: GROUND
I EN16-006	ENGINE CRANK: B+
I EN16-007	IGNITION ON: B+
I EN16-008	BRAKE ON / OFF SWITCH: NORMALLY OPEN / B+ WHEN ACTIVATED
I EN16-010	INERTIA SWITCH: NORMALLY CLOSED / OPEN CIRCUIT WHEN ACTIVATED
SS EN16-012	SENSOR POWER SUPPLY 1: NOMINAL 5 V
SS EN16-013	SENSOR POWER SUPPLY 2: NOMINAL 5 V
SG EN16-017	SMALL SIGNAL GROUND 1: GROUND
SG EN16-018	SMALL SIGNAL GROUND 2: GROUND
SG EN16-019	SENSOR GROUND 1: GROUND
SG EN16-020	SENSOR GROUND 2: GROUND
B+ EN16-022	BATTERY POWER SUPPLY: B+
B+ EN16-023	EMS SWITCHED POWER SUPPLY 1: B+
B+ EN16-024	EMS SWITCHED POWER SUPPLY 2: B+
SG EN16-029	HO2 SENSOR HEATER GROUND – 1/1: GROUND
SG EN16-030	HO2 SENSOR HEATER GROUND – 1/1: GROUND
I EN16-031	PARK / NEUTRAL SWITCH (AUTOMATIC TRANSMISSION): NORMALLY CLOSED / GROUND WHEN ACTIVATED
I EN16-031	CLUTCH PEDAL SAFETY SWITCH (MANUAL TRANSMISSION): NORMALLY OPEN / B+ WHEN ACTIVATED
I EN16-036	CRANKSHAFT SENSOR SIGNAL: PULSED SIGNAL, 70 PULSES PER ENGINE CYCLE
SG EN16-037	CRANKSHAFT SENSOR SIGNAL GROUND: GROUND
O EN16-038	INTAKE MANIFOLD TUNING VALVE SOLENOID DRIVE – 1 / TOP: GROUND WHEN ACTIVATED
O EN16-039	INTAKE MANIFOLD TUNING VALVE SOLENOID DRIVE – 2 / BOTTOM: GROUND WHEN ACTIVATED
O EN16-040	EMS CONTROL RELAY DRIVE: TO ACTIVATE, ECM SWITCHES CIRCUIT TO GROUND
O EN16-041	STARTER RELAY DRIVE: TO ACTIVATE, ECM SWITCHES CIRCUIT TO GROUND
SG EN16-043	TP AND APP SIGNALS SHIELD: GROUND
I EN16-044	MASS AIR FLOW SENSOR SIGNAL: NOMINAL 0 – 5 V BY ENGINE OPERATING CONDITION
SG EN16-045	MASS AIR FLOW SENSOR GROUND: GROUND
SG EN16-046	MASS AIR FLOW SENSOR GROUND: GROUND
I EN16-050	ENGINE FUEL TEMPERATURE SENSOR SIGNAL, NOMINAL 0 – 5 V: NTC SENSOR – VOLTAGE DECREASES AS TEMPERATURE INCREASES
O EN16-052	THROTTLE MOTOR RELAY DRIVE: TO ACTIVATE, ECM SWITCHES CIRCUIT TO GROUND
O EN16-053	GENERATOR CHARGE: VARIABLE VOLTAGE
SG EN16-054	THROTTLE MOTOR GROUND: GROUND
O EN16-055	HO2 SENSOR HEATER CONTROL – 2/1: PWM, 1 CYCLE PER 128 ms, VARIABLE DUTY CYCLE
O EN16-056	HO2 SENSOR HEATER CONTROL – 2/1: PWM, 1 CYCLE PER 128 ms, VARIABLE DUTY CYCLE
I EN16-065	GENERATOR FIELD RETURN SIGNAL: VARIABLE VOLTAGE BY GENERATOR OPERATING CONDITION
O EN16-066	EVAP CANISTER PURGE VALVE DRIVE: PWM, 10 Hz, POSITIVE DUTY CYCLE RANGE 0.04% – 100%
O EN16-067	EVAP CANISTER CLOSE VALVE DRIVE: TO CLOSE, ECM SWITCHES CIRCUIT TO GROUND
I EN16-068	BANK 2 CAMSHAFT SENSOR SIGNAL: PULSED SIGNAL, 4 PULSES PER ENGINE CYCLE
SG EN16-069	BANK 2 CAMSHAFT SENSOR GROUND: GROUND
I EN16-070	ENGINE COOLANT TEMPERATURE SENSOR SIGNAL, NOMINAL 0 – 5 V: NTC SENSOR – VOLTAGE DECREASES AS TEMPERATURE INCREASES
I EN16-071	INTAKE AIR TEMPERATURE SENSOR SIGNAL, NOMINAL 0 – 5 V: NTC SENSOR – VOLTAGE DECREASES AS TEMPERATURE INCREASES
I EN16-073	INJECTION PRESSURE SENSOR SIGNAL, NOMINAL 0 – 5 V: POTENTIOMETER – VOLTAGE DECREASES AS PRESSURE INCREASES
I EN16-075	THROTTLE POSITION SENSOR 1 SIGNAL: IDLE = 0.74 V; FULL THROTTLE = 3.97 V
I EN16-076	THROTTLE POSITION SENSOR 2 SIGNAL: IDLE = 1.65 V; FULL THROTTLE = 4.20 V
I EN16-078	ENGINE OIL TEMPERATURE SENSOR SIGNAL, NOMINAL 0 – 5 V: NTC SENSOR – VOLTAGE DECREASES AS TEMPERATURE INCREASES
I EN16-079	GENERATOR LOAD: B+ = NORMAL, AFTER-START SWITCH-ON; GROUND = GENERATOR FAILURE, AFTER-START SWITCH-ON
O EN16-080	THROTTLE MOTOR DRIVE: B+ TO ACTIVATE MOTOR
SG EN16-081	HO2 SENSOR HEATER GROUND – 2/1: GROUND
SG EN16-082	HO2 SENSOR HEATER GROUND – 2/1: GROUND
I EN16-083	HO2 SENSOR 1/1 SIGNAL: VARIABLE CURRENT
I EN16-084	HO2 SENSOR 1/1 SIGNAL: CONSTANT CURRENT
SG EN16-091	HO2 SENSOR HEATERS 1/2, 2/2 GROUND: GROUND
O EN16-092	HO2 SENSOR HEATER CONTROL – 1/2: PWM, 1 CYCLE PER 256 ms, POSITIVE DUTY CYCLE RANGE 0 ms = 0%, 77 ms = 30%, 256 ms = 100%
O EN16-093	HO2 SENSOR HEATER CONTROL – 2/2: PWM, 1 CYCLE PER 256 ms, POSITIVE DUTY CYCLE RANGE 0 ms = 0%, 77 ms = 30%, 256 ms = 100%
I EN16-094	BANK 1 CAMSHAFT SENSOR SIGNAL: PULSED SIGNAL, 4 PULSES PER ENGINE CYCLE
SG EN16-095	BANK 1 CAMSHAFT SENSOR GROUND: GROUND
I EN16-098	KNOCK SENSOR SIGNAL: PULSED SIGNAL
SG EN16-100	SENSOR SHIELD: GROUND
I EN16-102	ACCELERATOR PEDAL POSITION SENSOR 1 SIGNAL: FOOT OFF = 0.97 V; FULLY DEPRESSED = 3.33 V
I EN16-103	ACCELERATOR PEDAL POSITION SENSOR 2 SIGNAL: FOOT OFF = 3.97 V; FULLY DEPRESSED = 0.84 V
I EN16-104	FUEL TANK PRESSURE SENSOR SIGNAL, NOMINAL 0 – 5 V: VOLTAGE DECREASES AS PRESSURE INCREASES
D EN16-105	SERIAL DATA LINK: SERIAL COMMUNICATION
O EN16-106	THROTTLE MOTOR DRIVE: B+ TO ACTIVATE MOTOR
I EN16-107	HO2 SENSOR 2/1 SIGNAL: VARIABLE CURRENT
I EN16-108	HO2 SENSOR 2/1 SIGNAL: CONSTANT CURRENT
O EN16-109	BANK 1 VVT SOLENOID VALVE: PWM, 300 Hz, POSITIVE DUTY CYCLE RANGE 0% – 100%
O EN16-110	BANK 2 VVT SOLENOID VALVE: PWM, 300 Hz, POSITIVE DUTY CYCLE RANGE 0% – 100%
SG EN16-111	BANK 1 FUEL INJECTORS (1, 3, 5) GROUND: GROUND
SG EN16-116	BANK 2 FUEL INJECTORS (2, 4, 6) GROUND: GROUND
C EN16-123	CAN –
C EN16-124	CAN +
I EN16-127	MAP SENSOR SIGNAL, NOMINAL 0 – 5 V: VOLTAGE INCREASES AS MANIFOLD ABSOLUTE PRESSURE INCREASES
I EN16-128	HO2 SENSOR 1/2 SIGNAL, NOMINAL 1 V SWING: 0.1 – 0.9 V SWING
I EN16-129	HO2 SENSOR 2/2 SIGNAL, NOMINAL 1 V SWING: 0.1 – 0.9 V SWING
SG EN16-130	HO2 SENSORS SHIELD: GROUND
B+ EN16-134	THROTTLE MOTOR POWER SUPPLY: B+ WHEN RELAY ACTIVATED

NOTE: Refer to the Appendix at the rear of this book for Network Messages.

The following abbreviations are used to represent values for Control Module Pin-Out data

I	Input	PG	Power Ground	CAN	CAN Network	D	Serial and Encoded Data
O	Output	SS	Sensor / Signal Supply V	SCP	SCP Network	V	Voltage (DC)
B+	Battery Voltage	SG	Sensor / Signal Ground	D2	D2B Network	PWM	Pulse Width Modulated

CAUTION: The information on this data page is furnished to aid the user in understanding circuit operation. THIS INFORMATION SHOULD BE USED FOR REFERENCE ONLY.

NOTE: The characteristics listed are approximately those that can be expected at the control module connector pins with all circuit connections made and all components connected and fitted.

Fig. 03.1

COMPONENTS

Component	Connector(s)	Connector Description	Location
APP SENSOR	PA1	6-WAY / BLACK	ABOVE ACCELERATOR PEDAL
BRAKE ON / OFF SWITCH	PA3	3-WAY / BLACK	TOP OF BRAKE PEDAL
CENTRAL JUNCTION FUSE BOX	CA75 CA76 CA77 CA78	8-WAY / GREY 16-WAY / GREEN 2-WAY / GREY 16-WAY / GREY	PASSENGER COMPARTMENT, FRONT BULKHEAD LH SIDE
	IP1	14-WAY / GREEN	
	IP2	16-WAY / GREY	
	IP3	2-WAY / GREY	
	IP4	14-WAY / GREY	
	JB50	4-WAY / GREY	
	JB51	16-WAY / BLUE	
	JB52	2-WAY / BLACK	
CKP SENSOR	EN12	2-WAY / BLACK	ADJACENT TO ENGINE CRANKSHAFT PULLEY
CMP SENSOR 1	EN43	2-WAY / BLACK	BANK 1 CYLINDER HEAD, FRONT
CMP SENSOR 2	EN33	2-WAY / BLACK	BANK 2 CYLINDER HEAD, FRONT
ECT SENSOR	EN18	2-WAY / BLACK	ENGINE VEE, FRONT
EFT SENSOR	IL8	2-WAY / BLACK	FUEL RAIL, FRONT
ENGINE CONTROL MODULE (2.5L & 3.0L)	EN16	134-WAY / BLACK	ENGINE COMPARTMENT, FRONT BULKHEAD RH SIDE
EOT SENSOR	EN25	2-WAY / BLACK	ADJACENT TO ENGINE OIL FILTER
EVAP CANISTER CLOSE VALVE	FT5	2-WAY / BLACK	REARWARD OF FUEL TANK
EVAP CANISTER PURGE VALVE	JB170	2-WAY / BLACK	REARWARD OF FUEL TANK
FTP SENSOR	FT1	3-WAY / BLACK	TOP OF FUEL TANK
HO2 SENSOR DOWNSTREAM 1/2	EN14	4-WAY / BLACK	BANK 1 EXHAUST
HO2 SENSOR DOWNSTREAM 2/2	EN9	4-WAY / BLACK	BANK 2 EXHAUST
HO2 SENSOR UPSTREAM 1/1	EN37	4-WAY / GREY	BANK 1 EXHAUST
HO2 SENSOR UPSTREAM 2/1	EN32	4-WAY / GREY	BANK 2 EXHAUST
IMT SOLENOID VALVE 1	EN999	2-WAY / BLACK	INTAKE MANIFOLD TOP
IMT SOLENOID VALVE 2	EN998	2-WAY / BLACK	INTAKE MANIFOLD BOTTOM
IP SENSOR	IL7	3-WAY / BLACK	FUEL RAIL REAR
KNOCK SENSOR	EN23	2-WAY / BLACK	ENGINE VEE
MAF SENSOR	EN6	5-WAY / BLACK	ENGINE AIR INTAKE DUCT
MAP SENSOR	EN8	4-WAY / BLACK	INTAKE MANIFOLD, REAR
POWER DISTRIBUTION FUSE BOX	—	—	ENGINE COMPARTMENT LH SIDE
THROTTLE BODY	EN10 EN13	2-WAY / BLACK 4-WAY / BLACK	ENGINE INTAKE MANIFOLD
THROTTLE MOTOR	EN10	2-WAY / BLACK	ENGINE INTAKE MANIFOLD
THROTTLE MOTOR RELAY	—	—	POWER DISTRIBUTION FUSE BOX R11
TP SENSOR (2.5L & 3.0L)	EN13	4-WAY / BLACK	ENGINE INTAKE MANIFOLD
VVT SOLENOID VALVE 1	EN61	2-WAY / BLACK	BANK 1 CYLINDER HEAD
VVT SOLENOID VALVE 2	EN42	2-WAY / BLACK	BANK 2 CYLINDER HEAD

HARNESS IN-LINE CONNECTORS

Connector	Connector Description	Location
CA5	12-WAY / BLACK / CABIN HARNESS TO FUEL TANK LINK LEAD	TOP OF FUEL TANK
CA10	22-WAY / GREY / ENGINE HARNESS TO CABIN HARNESS	BELOW THE GLOVEBOX
CA170	16-WAY / GREEN / IN-LINE CONNECTOR	LH LOWER A POST
EN4	12-WAY / BLACK / ENGINE HARNESS TO INJECTOR RAIL HARNESS	ADJACENT TO THE TRANSMISSION BELL HOUSING
JB1	42-WAY / BLACK / JUNCTION BOX HARNESS TO ENGINE HARNESS	ADJACENT TO LH SUSPENSION TURRET
JB2	16-WAY / GREEN / JUNCTION BOX HARNESS TO CABIN HARNESS	ADJACENT TO CENTRAL JUNCTION FUSE BOX

GROUND S

Ground	Location
G8	ENGINE COMPARTMENT / RH INNER WHEEL ARCH

FOR CONTROL MODULE PIN-OUT INFORMATION, UNFOLD PAGE TO LEFT.

Refer to the front of this book for detailed information and illustrations regarding the location and identification of harnesses, relays, fuses, grounds, control modules and control module pins.

Engine Control Module (2.5L & 3.0L)

Pin	Description and Characteristic
I EN16-009	BRAKE CANCEL SWITCH: NORMALLY CLOSED / GROUND WHEN ACTIVATED
SS EN16-012	SENSOR POWER SUPPLY 1: NOMINAL 5 V
SG EN16-019	SENSOR GROUND 1: GROUND
I EN16-025	FUEL PUMP MODULE MONITOR: PWM, 1 Hz, 50% POSITIVE DUTY CYCLE = NORMAL, 25% POSITIVE DUTY CYCLE = NO CONTROL SIGNAL, 75% POSITIVE DUTY CYCLE = FUEL PUMP INOPERATIVE
O EN16-027	FUEL PUMP MODULE CONTROL: PWM, 250 Hz, NORMAL POSITIVE DUTY CYCLE RANGE = 4% – 51%
I EN16-033	CLUTCH CANCEL SWITCH: NORMALLY CLOSED / GROUND WHEN ACTIVATED
O EN16-034	AIR CONDITIONING COMPRESSOR CLUTCH RELAY DRIVE: TO ACTIVATE, ECM SWITCHES CIRCUIT TO GROUND
I EN16-047	SPEED CONTROL SWITCH REQUEST: STEPPED RESISTANCE
SG EN16-048	SPEED CONTROL SWITCHES SIGNAL GROUND: GROUND
O EN16-051	COOLING FAN MODULE CONTROL: PWM, 140 Hz, POSITIVE DUTY CYCLE RANGE 7% – 95%
O EN16-061	IGNITION COIL ACTIVATE – CYLINDER 2: TO ACTIVATE, ECM SWITCHES CIRCUIT TO GROUND
O EN16-062	IGNITION COIL ACTIVATE – CYLINDER 4: TO ACTIVATE, ECM SWITCHES CIRCUIT TO GROUND
O EN16-063	IGNITION COIL ACTIVATE – CYLINDER 6: TO ACTIVATE, ECM SWITCHES CIRCUIT TO GROUND
O EN16-087	IGNITION COIL ACTIVATE – CYLINDER 1: TO ACTIVATE, ECM SWITCHES CIRCUIT TO GROUND
O EN16-088	IGNITION COIL ACTIVATE – CYLINDER 3: TO ACTIVATE, ECM SWITCHES CIRCUIT TO GROUND
O EN16-089	IGNITION COIL ACTIVATE – CYLINDER 5: TO ACTIVATE, ECM SWITCHES CIRCUIT TO GROUND
O EN16-113	FUEL INJECTOR DRIVE – CYLINDER 5: TO ACTIVATE, ECM SWITCHES CIRCUIT TO GROUND
O EN16-114	FUEL INJECTOR DRIVE – CYLINDER 3: TO ACTIVATE, ECM SWITCHES CIRCUIT TO GROUND
O EN16-115	FUEL INJECTOR DRIVE – CYLINDER 1: TO ACTIVATE, ECM SWITCHES CIRCUIT TO GROUND
O EN16-118	FUEL INJECTOR DRIVE – CYLINDER 6: TO ACTIVATE, ECM SWITCHES CIRCUIT TO GROUND
O EN16-119	FUEL INJECTOR DRIVE – CYLINDER 4: TO ACTIVATE, ECM SWITCHES CIRCUIT TO GROUND
O EN16-120	FUEL INJECTOR DRIVE – CYLINDER 2: TO ACTIVATE, ECM SWITCHES CIRCUIT TO GROUND
I EN16-121	AIR CONDITIONING PRESSURE SENSOR SIGNAL, NOMINAL 0 – 5 V: TRANSDUCER – VOLTAGE INCREASES AS PRESSURE INCREASES
I EN16-131	IGNITION MONITOR BANK 1 (1, 3, 5): PULSED SIGNAL, 3 PULSES PER ENGINE CYCLE
I EN16-132	IGNITION MONITOR BANK 2 (2, 4, 6): PULSED SIGNAL, 3 PULSES PER ENGINE CYCLE
SG EN16-133	FUEL PUMP CONTROL CIRCUIT SHIELD: GROUND

COMPONENTS

Component	Connector(s)	Connector Description	Location
AIR CONDITIONING COMPRESSOR CLUTCH RELAY	—	—	POWER DISTRIBUTION FUSE BOX R6
AIR CONDITIONING COMPRESSOR CLUTCH	EN30	2-WAY / BLACK	ADJACENT TO ENGINE OIL FILTER
AIR CONDITIONING PRESSURE SENSOR	JB106	4-WAY / BLACK	BEHIND FRONT LH WHEEL ARCH LINER
BRAKE CANCEL SWITCH	PA2	2-WAY / BLACK	TOP OF BRAKE PEDAL
CLUTCH CANCEL SWITCH	PA4	5-WAY / BLACK	TOP OF CLUTCH PEDAL
COOLING FAN – LH	GCC2	2-WAY / BLACK	COOLING PACK LH SIDE
COOLING FAN – RH	GC1	2-WAY / BLACK	COOLING PACK RH SIDE
COOLING FAN MODULE	JB188 PWM1	2-WAY / BLACK 4-WAY	ADJACENT TO RADIATOR LH SIDE
ENGINE CONTROL MODULE (2.5L & 3.0L)	EN16	134-WAY / BLACK	ENGINE COMPARTMENT, FRONT BULKHEAD RH SIDE
FUEL INJECTOR 1	IL1	2-WAY / BLACK	FUEL RAIL
FUEL INJECTOR 2	IL4	2-WAY / BLACK	FUEL RAIL
FUEL INJECTOR 3	IL2	2-WAY / BLACK	FUEL RAIL
FUEL INJECTOR 4	IL5	2-WAY / BLACK	FUEL RAIL
FUEL INJECTOR 5	IL3	2-WAY / BLACK	FUEL RAIL
FUEL INJECTOR 6	IL6	2-WAY / BLACK	FUEL RAIL
FUEL PUMP	FT2	4-WAY / BLACK	FUEL TANK
FUEL PUMP MODULE	CA105	10-WAY / BLACK	UNDER REAR SEAT LH SIDE
IGNITION CAPACITOR	EN94	2-WAY / BLACK	BELOW AIR INTAKE
IGNITION MODULE AND COIL 1	EN51	4-WAY	BANK 1 CYLINDER HEAD
IGNITION MODULE AND COIL 2	EN54	4-WAY	BANK 2 CYLINDER HEAD
IGNITION MODULE AND COIL 3	EN52	4-WAY	BANK 1 CYLINDER HEAD
IGNITION MODULE AND COIL 4	EN55	4-WAY	BANK 2 CYLINDER HEAD
IGNITION MODULE AND COIL 5	EN53	4-WAY	BANK 1 CYLINDER HEAD
IGNITION MODULE AND COIL 6	EN56	4-WAY	BANK 2 CYLINDER HEAD
POWER DISTRIBUTION FUSE BOX	—	—	ENGINE COMPARTMENT LH SIDE
SPEED CONTROL SWITCHES	SW5	4-WAY / BLACK	STEERING WHEEL

HARNESS IN-LINE CONNECTORS

Connector	Connector Description	Location
CA5	12-WAY / BLACK / CABIN HARNESS TO FUEL TANK LINK LEAD	TOP OF FUEL TANK
CA10	22-WAY / GREY / ENGINE HARNESS TO CABIN HARNESS	BELOW THE GLOVEBOX
CA170	16-WAY / GREEN / IN-LINE CONNECTOR	LH LOWER A POST
EN4	12-WAY / BLACK / ENGINE HARNESS TO INJECTOR RAIL HARNESS	ADJACENT TO THE TRANSMISSION BELL HOUSING
JB1	42-WAY / BLACK / JUNCTION BOX HARNESS TO ENGINE HARNESS	ADJACENT TO LH SUSPENSION TURRET
JB2	16-WAY / GREEN / JUNCTION BOX HARNESS TO CABIN HARNESS	ADJACENT TO CENTRAL JUNCTION FUSE BOX
JB129	22-WAY / GREY / INSTRUMENT PANEL HARNESS TO JUNCTION BOX HARNESS	LH LOWER A POST
JB145	8-WAY / BLACK / ENGINE HARNESS TO JUNCTION BOX HARNESS	ADJACENT TO CENTRAL JUNCTION FUSE BOX
JB187	2-WAY / BLACK / JUNCTION BOX HARNESS TO COOLING FAN MODULE LINK LEAD	ADJACENT TO RADIATOR LH SIDE

GROUND

Ground	Location
G8	ENGINE COMPARTMENT / RH INNER WHEEL ARCH
G11	ENGINE COMPARTMENT / UNDER LH HEADLAMP ASSEMBLY
G17	ENGINE COMPARTMENT / ON GENERATOR BRACKET
G35	PASSENGER COMPARTMENT / LH LOWER E POST

FOR CONTROL MODULE PIN-OUT INFORMATION, UNFOLD PAGE TO LEFT.

The following abbreviations are used to represent values for Control Module Pin-Out data

I	Input	PG	Power Ground	CAN	CAN Network	D	Serial and Encoded Data
O	Output	SS	Sensor / Signal Supply V	SCP	SCP Network	V	Voltage (DC)
B+	Battery Voltage	SG	Sensor / Signal Ground	D2	D2B Network	PWM	Pulse Width Modulated

CAUTION: The information on this data page is furnished to aid the user in understanding circuit operation. THIS INFORMATION SHOULD BE USED FOR REFERENCE ONLY.

NOTE: The characteristics listed are approximately those that can be expected at the control module connector pins with all circuit connections made and all components connected and fitted.

Refer to the front of this book for detailed information and illustrations regarding the location and identification of harnesses, relays, fuses, grounds, control modules and control module pins.

CONTROL MODULE PIN-OUT INFORMATION

Engine Control Module (2.0L)

Pin	Description and Characteristic
I EN65-001	MAP SENSOR SIGNAL, NOMINAL 0 – 5 V: VOLTAGE INCREASES AS MANIFOLD ABSOLUTE PRESSURE INCREASES
I EN65-002	AIR CONDITIONING PRESSURE SENSOR SIGNAL, NOMINAL 0 – 5 V: TRANSDUCER – VOLTAGE INCREASES AS PRESSURE INCREASES
SG EN65-003	SENSOR GROUND: GROUND
SG EN65-004	SMALL SIGNAL GROUND1: GROUND
SG EN65-005	SMALL SIGNAL GROUND 2: GROUND
I EN65-006	ENGINE CRANK: B+
SS EN65-011	SENSOR POWER SUPPLY: NOMINAL 5 V
PG EN65-018	POWER GROUND 2: GROUND
PG EN65-019	POWER GROUND 1: GROUND
B+ EN65-021	BATTERY POWER SUPPLY: B+
B+ EN65-022	EMS SWITCHED POWER SUPPLY 1: B+
B+ EN65-023	EMS SWITCHED POWER SUPPLY 2: B+
I EN65-025	HO2 SENSOR 2/1 SIGNAL: CONSTANT CURRENT
I EN65-026	HO2 SENSOR 2/1 SIGNAL: VARIABLE CURRENT
I EN65-027	THROTTLE POSITION SENSOR SIGNAL: CLOSED THROTTLE = 0.89 V; FULL THROTTLE = 4.50 V
SG EN65-028	SENSOR SHIELD: GROUND
SG EN65-029	MASS AIR FLOW SENSOR GROUND: GROUND
I EN65-030	MASS AIR FLOW SENSOR SIGNAL: NOMINAL 0 – 5 V BY ENGINE OPERATING CONDITION
SG EN65-031	MASS AIR FLOW SENSOR GROUND: GROUND
I EN65-034	BRAKE ON / OFF SWITCH: NORMALLY OPEN / B+ WHEN ACTIVATED
I EN65-035	GENERATOR LOAD: B+ = NORMAL, AFTER-START SWITCH-ON; GROUND = GENERATOR FAILURE, AFTER-START SWITCH-ON
I EN65-036	INERTIA SWITCH: NORMALLY CLOSED / GROUND WHEN ACTIVATED
I EN65-037	KNOCK SENSOR SIGNAL: PULSED SIGNAL
SG EN65-038	SENSOR SHIELD: GROUND
D EN65-039	SERIAL DATA LINK: SERIAL COMMUNICATION
I EN65-043	GENERATOR CHARGE: VARIABLE VOLTAGE
O EN65-044	COOLING FAN MODULE CONTROL: PWM, 140Hz, POSITIVE DUTY CYCLE RANGE 7% – 95%
O EN65-046	HO2 SENSOR HEATER CONTROL – 2/2: PWM, 1 CYCLE PER 256 mS, POSITIVE DUTY CYCLE RANGE 0 mS = 0%, 77 mS = 30%, 256 mS = 100%
O EN65-047	HO2 SENSOR HEATER CONTROL – 1/2: PWM, 1 CYCLE PER 256 mS, POSITIVE DUTY CYCLE RANGE 0 mS = 0%, 77 mS = 30%, 256 mS = 100%
SG EN65-048	HO2 SENSOR HEATER GROUND – 1/2 AND 2/2: GROUND
I EN65-050	HO2 SENSOR 1/1 SIGNAL: CONSTANT CURRENT
I EN65-051	HO2 SENSOR 1/1 SIGNAL: VARIABLE CURRENT
SG EN65-052	HO2 SENSOR HEATER GROUND – 2/1: GROUND
I EN65-053	HO2 SENSOR 1/2 SIGNAL, NOMINAL 1 V SWING: 0.1 – 0.9 V SWING
I EN65-054	HO2 SENSOR 2/2 SIGNAL, NOMINAL 1 V SWING: 0.1 – 0.9 V SWING
SG EN65-055	HO2 SENSORS SHIELD: GROUND
I EN65-059	BANK 1 CAMSHAFT SENSOR SIGNAL: PULSED SIGNAL, 4 PULSES PER ENGINE CYCLE
SG EN65-060	BANK 1 CAMSHAFT SENSOR GROUND: GROUND
I EN65-061	CRANKSHAFT SENSOR SIGNAL: PULSED SIGNAL, 70 PULSES PER ENGINE CYCLE
SG EN65-062	CRANKSHAFT SENSOR SIGNAL GROUND: GROUND
I EN65-063	IGNITION ON: B+
SG EN65-064	BANK 2 FUEL INJECTORS (2, 4, 6) GROUND: GROUND
O EN65-068	STARTER RELAY DRIVE: TO ACTIVATE, ECM SWITCHES CIRCUIT TO GROUND
O EN65-069	EMS CONTROL RELAY DRIVE: TO ACTIVATE, ECM SWITCHES CIRCUIT TO GROUND
O EN65-070	INTAKE MANIFOLD TUNING VALVE SOLENOID DRIVE – 2 / BOTTOM: GROUND WHEN ACTIVATED
O EN65-071	INTAKE MANIFOLD TUNING VALVE SOLENOID DRIVE – 1 / TOP: GROUND WHEN ACTIVATED
O EN65-074	EVAP CANISTER PURGE VALVE DRIVE: PWM, 10 Hz, POSITIVE DUTY CYCLE RANGE 0.04% – 100%
SG EN65-075	HO2 SENSOR HEATER GROUND – 1/1: GROUND
O EN65-077	HO2 SENSOR HEATER CONTROL – 1/1: PWM, 1 CYCLE PER 128 mS, VARIABLE DUTY CYCLE
SG EN65-078	HO2 SENSOR HEATER GROUND – 2/1: GROUND
I EN65-079	ENGINE OIL TEMPERATURE SENSOR SIGNAL, NOMINAL 0 – 5 V: NTC SENSOR – VOLTAGE DECREASES AS TEMPERATURE INCREASES
I EN65-080	ENGINE COOLANT TEMPERATURE SENSOR SIGNAL, NOMINAL 0 – 5 V: NTC SENSOR – VOLTAGE DECREASES AS TEMPERATURE INCREASES
I EN65-081	INTAKE AIR TEMPERATURE SENSOR SIGNAL, NOMINAL 0 – 5 V: NTC SENSOR – VOLTAGE DECREASES AS TEMPERATURE INCREASES
I EN65-085	PARK / NEUTRAL SWITCH (AUTOMATIC TRANSMISSION): NORMALLY CLOSED / GROUND WHEN ACTIVATED
I EN65-085	CLUTCH SAFETY CIRCUIT (MANUAL TRANSMISSION): B+
I EN65-086	BANK 2 CAMSHAFT SENSOR SIGNAL: PULSED SIGNAL, 4 PULSES PER ENGINE CYCLE
SG EN65-087	BANK 2 CAMSHAFT SENSOR GROUND: GROUND
C EN65-088	CAN –
C EN65-089	CAN +
SG EN65-091	BANK 1 FUEL INJECTORS (1, 3, 5) GROUND: GROUND
O EN65-095	BANK 2 VVT SOLENOID VALVE: PWM, 300Hz, POSITIVE DUTY CYCLE RANGE 0% – 100%
O EN65-096	BANK 1 VVT SOLENOID VALVE: PWM, 300Hz, POSITIVE DUTY CYCLE RANGE 0% – 100%
O EN65-097	IDLE SPEED CONTROL VALVE MOTOR DRIVE (-): PWM
O EN65-098	IDLE SPEED CONTROL VALVE MOTOR DRIVE (+): PWM
SG EN65-102	HO2 SENSOR HEATER GROUND – 1/1: GROUND
O EN65-103	HO2 SENSOR HEATER CONTROL – 2/1: PWM, 1 CYCLE PER 128 mS, VARIABLE DUTY CYCLE
O EN65-104	HO2 SENSOR HEATER CONTROL – 1/1: PWM, 1 CYCLE PER 128 mS, VARIABLE DUTY CYCLE

NOTE: Refer to the Appendix at the rear of this book for Network Messages.

The following abbreviations are used to represent values for Control Module Pin-Out data

I	Input	PG	Power Ground	CAN	CAN Network	D	Serial and Encoded Data
O	Output	SS	Sensor / Signal Supply V	SCP	SCP Network	V	Voltage (DC)
B+	Battery Voltage	SG	Sensor / Signal Ground	D2	D2B Network	PWM	Pulse Width Modulated

CAUTION: The information on this data page is furnished to aid the user in understanding circuit operation. THIS INFORMATION SHOULD BE USED FOR REFERENCE ONLY.

NOTE: The characteristics listed are approximately those that can be expected at the control module connector pins with all circuit connections made and all components connected and fitted.

Fig. 03.3

COMPONENTS

Component	Connector(s)	Connector Description	Location
BRAKE ON / OFF SWITCH	PA3	3-WAY / BLACK	TOP OF BRAKE PEDAL
CENTRAL JUNCTION FUSE BOX	CA75	8-WAY / GREY	PASSENGER COMPARTMENT, FRONT BULKHEAD LH SIDE
	CA76	16-WAY / GREEN	
	CA77	2-WAY / GREY	
	CA78	16-WAY / GREY	
	IP1	14-WAY / GREEN	
	IP2	16-WAY / GREY	
	IP3	2-WAY / GREY	
	IP4	14-WAY / GREY	
	JB50	4-WAY / GREY	
	JB51	16-WAY / BLUE	
	JB52	2-WAY / BLACK	
CKP SENSOR	EN12	2-WAY / BLACK	ADJACENT TO ENGINE CRANKSHAFT PULLEY
CMP SENSOR 1	EN43	2-WAY / BLACK	BANK 1 CYLINDER HEAD, FRONT
CMP SENSOR 2	EN33	2-WAY / BLACK	BANK 2 CYLINDER HEAD, FRONT
ECT SENSOR	EN18	2-WAY / BLACK	ENGINE VEE, FRONT
ENGINE CONTROL MODULE (2.0L)	EN65	104-WAY / BLACK	ENGINE COMPARTMENT, FRONT BULKHEAD RH SIDE
EOT SENSOR	EN25	2-WAY / BLACK	ADJACENT TO ENGINE OIL FILTER
EVAP CANISTER PURGE VALVE	JB170	2-WAY / BLACK	REARWARD OF FUEL TANK
HO2 SENSOR DOWNSTREAM 1/2	EN14	4-WAY / BLACK	BANK 1 EXHAUST
HO2 SENSOR DOWNSTREAM 2/2	EN9	4-WAY / BLACK	BANK 2 EXHAUST
HO2 SENSOR UPSTREAM 1/1	EN37	4-WAY / GREY	BANK 1 EXHAUST
HO2 SENSOR UPSTREAM 2/1	EN32	4-WAY / GREY	BANK 2 EXHAUST
IDLE SPEED CONTROL VALVE	EN87	2-WAY / BLACK	THROTTLE ASSEMBLY
IMT SOLENOID VALVE 1	EN999	2-WAY / BLACK	INTAKE MANIFOLD TOP
IMT SOLENOID VALVE 2	EN998	2-WAY / BLACK	INTAKE MANIFOLD BOTTOM
KNOCK SENSOR	EN23	2-WAY / BLACK	ENGINE VEE
MAF SENSOR	EN6	5-WAY / BLACK	ENGINE AIR INTAKE DUCT
MAP SENSOR	EN8	4-WAY / BLACK	INTAKE MANIFOLD, REAR
TP SENSOR (2.0L)	EN88	3-WAY / BLACK	ENGINE INTAKE MANIFOLD
VVT SOLENOID VALVE 1	EN61	2-WAY / BLACK	BANK 1 CYLINDER HEAD
VVT SOLENOID VALVE 2	EN42	2-WAY / BLACK	BANK 2 CYLINDER HEAD

HARNESS IN-LINE CONNECTORS

Connector	Connector Description	Location
CA10	22-WAY / GREY / ENGINE HARNESS TO CABIN HARNESS	BELOW THE GLOVEBOX
CA170	16-WAY / GREEN / IN-LINE CONNECTOR	LH LOWER A POST
JB1	42-WAY / BLACK / JUNCTION BOX HARNESS TO ENGINE HARNESS	ADJACENT TO LH SUSPENSION TURRET
JB196	10-WAY / GREY / JUNCTION BOX HARNESS TO CABIN HARNESS	ADJACENT TO FOOT PEDALS

GROUND

Ground	Location
G8	ENGINE COMPARTMENT / RH INNER WHEEL ARCH

FOR CONTROL MODULE PIN-OUT INFORMATION, UNFOLD PAGE TO LEFT.

Refer to the front of this book for detailed information and illustrations regarding the location and identification of harnesses, relays, fuses, grounds, control modules and control module pins.

Engine Control Module (2.0L)

Pin	Description and Characteristic
I EN65-002	AIR CONDITIONING PRESSURE SENSOR SIGNAL, NOMINAL 0 – 5 V: TRANSDUCER – VOLTAGE INCREASES AS PRESSURE INCREASES
SG EN65-003	SENSOR GROUND: GROUND
I EN65-007	BRAKE CANCEL SWITCH: NORMALLY CLOSED / GROUND WHEN ACTIVATED
SS EN65-011	SENSOR POWER SUPPLY: NOMINAL 5 V
I EN65-012	IGNITION MONITOR BANK 1 (1, 3, 5) : PULSED SIGNAL, 3 PULSES PER ENGINE CYCLE
I EN65-013	IGNITION MONITOR BANK 2 (2, 4, 6) : PULSED SIGNAL, 3 PULSES PER ENGINE CYCLE
O EN65-014	IGNITION COIL ACTIVATE – CYLINDER 1: TO ACTIVATE, ECM SWITCHES CIRCUIT TO GROUND
O EN65-015	IGNITION COIL ACTIVATE – CYLINDER 3: TO ACTIVATE, ECM SWITCHES CIRCUIT TO GROUND
O EN65-016	IGNITION COIL ACTIVATE – CYLINDER 5: TO ACTIVATE, ECM SWITCHES CIRCUIT TO GROUND
I EN65-017	INTELLIGENT SPEED SIGNAL (VEHICLE SPEED) : PWM, DUTY CYCLE RANGE 30% to 70 %
O EN65-020	AIR CONDITIONING COMPRESSOR CLUTCH RELAY DRIVE: TO ACTIVATE, ECM SWITCHES CIRCUIT TO GROUND
I EN65-034	BRAKE ON / OFF SWITCH: NORMALLY OPEN / B+ WHEN ACTIVATED
O EN65-040	IGNITION COIL ACTIVATE – CYLINDER 2: TO ACTIVATE, ECM SWITCHES CIRCUIT TO GROUND
O EN65-041	IGNITION COIL ACTIVATE – CYLINDER 4: TO ACTIVATE, ECM SWITCHES CIRCUIT TO GROUND
O EN65-042	IGNITION COIL ACTIVATE – CYLINDER 6: TO ACTIVATE, ECM SWITCHES CIRCUIT TO GROUND
O EN65-044	COOLING FAN MODULE CONTROL: PWM, 140Hz, POSITIVE DUTY CYCLE RANGE 7% – 95%
I EN65-056	SPEED CONTROL STATUS 1 ON / OFF: GROUND = ON; 5 V = OFF
I EN65-057	SPEED CONTROL STATUS 2 ACTIVE / INACTIVE: GROUND = ACTIVE; 5 V = INACTIVE
O EN65-065	FUEL INJECTOR DRIVE – CYLINDER 1: TO ACTIVATE, ECM SWITCHES CIRCUIT TO GROUND
O EN65-066	FUEL INJECTOR DRIVE – CYLINDER 3: TO ACTIVATE, ECM SWITCHES CIRCUIT TO GROUND
O EN65-067	FUEL INJECTOR DRIVE – CYLINDER 5: TO ACTIVATE, ECM SWITCHES CIRCUIT TO GROUND
I EN65-084	CLUTCH CANCEL SWITCH: NORMALLY CLOSED / GROUND WHEN ACTIVATED
O EN65-092	FUEL INJECTOR DRIVE – CYLINDER 2: TO ACTIVATE, ECM SWITCHES CIRCUIT TO GROUND
O EN65-093	FUEL INJECTOR DRIVE – CYLINDER 4: TO ACTIVATE, ECM SWITCHES CIRCUIT TO GROUND
O EN65-094	FUEL INJECTOR DRIVE – CYLINDER 6: TO ACTIVATE, ECM SWITCHES CIRCUIT TO GROUND
O EN65-099	FUEL PUMP RELAY DRIVE: TO ACTIVATE, ECM SWITCHES CIRCUIT TO GROUND

COMPONENTS

Component	Connector(s)	Connector Description	Location
AIR CONDITIONING COMPRESSOR CLUTCH RELAY	—	—	POWER DISTRIBUTION FUSE BOX R6
AIR CONDITIONING COMPRESSOR CLUTCH	EN30	2-WAY / BLACK	ADJACENT TO ENGINE OIL FILTER
AIR CONDITIONING PRESSURE SENSOR	JB106	4-WAY / BLACK	BEHIND FRONT LH WHEEL ARCH LINER
BRAKE CANCEL SWITCH	PA2	2-WAY / BLACK	TOP OF BRAKE PEDAL
BRAKE ON / OFF SWITCH	PA3	3-WAY / BLACK	TOP OF BRAKE PEDAL
CENTRAL JUNCTION FUSE BOX	CA75	8-WAY / GREY	PASSENGER COMPARTMENT, FRONT BULKHEAD LH SIDE
	CA76	16-WAY / GREEN	
	CA77	2-WAY / GREY	
	CA78	16-WAY / GREY	
	IP1	14-WAY / GREEN	
	IP2	16-WAY / GREY	
	IP3	2-WAY / GREY	
	IP4	14-WAY / GREY	
	JB50	4-WAY / GREY	
	JB51	16-WAY / BLUE	
	JB52	2-WAY / BLACK	
CLUTCH CANCEL SWITCH	PA4	5-WAY / BLACK	TOP OF CLUTCH PEDAL
COOLING FAN – LH	GC2	2-WAY / BLACK	COOLING PACK LH SIDE
COOLING FAN – RH	GC1	2-WAY / BLACK	COOLING PACK RH SIDE
COOLING FAN MODULE	JB188	2-WAY / BLACK	ADJACENT TO RADIATOR LH SIDE
	PWM1	4-WAY	
ENGINE CONTROL MODULE (2.0L)	EN65	104-WAY / BLACK	ENGINE COMPARTMENT, FRONT BULKHEAD RH SIDE
FUEL INJECTOR 1	IL1	2-WAY / BLACK	FUEL RAIL
FUEL INJECTOR 2	IL4	2-WAY / BLACK	FUEL RAIL
FUEL INJECTOR 3	IL2	2-WAY / BLACK	FUEL RAIL
FUEL INJECTOR 4	IL5	2-WAY / BLACK	FUEL RAIL
FUEL INJECTOR 5	IL3	2-WAY / BLACK	FUEL RAIL
FUEL INJECTOR 6	IL6	2-WAY / BLACK	FUEL RAIL
FUEL PUMP (2.0L)	CA415	6-WAY / BLACK	FUEL TANK
FUEL PUMP RELAY	—	—	POWER DISTRIBUTION FUSE BOX R11
IGNITION CAPACITOR	EN94	2-WAY / BLACK	BELOW AIR INTAKE
IGNITION MODULE AND COIL 1	EN51	4-WAY	BANK 1 CYLINDER HEAD
IGNITION MODULE AND COIL 2	EN54	4-WAY	BANK 2 CYLINDER HEAD
IGNITION MODULE AND COIL 3	EN52	4-WAY	BANK 1 CYLINDER HEAD
IGNITION MODULE AND COIL 4	EN55	4-WAY	BANK 2 CYLINDER HEAD
IGNITION MODULE AND COIL 5	EN53	4-WAY	BANK 1 CYLINDER HEAD
IGNITION MODULE AND COIL 6	EN56	4-WAY	BANK 2 CYLINDER HEAD
POWER DISTRIBUTION FUSE BOX	—	—	ENGINE COMPARTMENT LH SIDE
SPEED CONTROL SWITCHES	SW5	4-WAY / BLACK	STEERING WHEEL
SPEED CONTROL CONTROL MODULE	JB161	10-WAY / BLACK	ENGINE COMPARTMENT, BULKHEAD LH SIDE

HARNESS IN-LINE CONNECTORS

Connector	Connector Description	Location
CA5	12-WAY / BLACK / CABIN HARNESS TO FUEL TANK LINK LEAD	TOP OF FUEL TANK
CA10	22-WAY / GREY / ENGINE HARNESS TO CABIN HARNESS	BELOW THE GLOVEBOX
CA170	16-WAY / GREEN / IN-LINE CONNECTOR	LH LOWER A POST
EN4	12-WAY / BLACK / ENGINE HARNESS TO INJECTOR RAIL HARNESS	ADJACENT TO THE TRANSMISSION BELL HOUSING
JB1	42-WAY / BLACK / JUNCTION BOX HARNESS TO ENGINE HARNESS	ADJACENT TO LH SUSPENSION TURRET
JB129	22-WAY / GREY / INSTRUMENT PANEL HARNESS TO JUNCTION BOX HARNESS	LH LOWER A POST
JB145	8-WAY / BLACK / ENGINE HARNESS TO JUNCTION BOX HARNESS	ADJACENT TO CENTRAL JUNCTION FUSE BOX
JB187	2-WAY / BLACK / JUNCTION BOX HARNESS TO COOLING FAN MODULE LINK LEAD	ADJACENT TO RADIATOR LH SIDE
JB196	10-WAY / GREY / JUNCTION BOX HARNESS TO CABIN HARNESS	ADJACENT TO FOOT PEDALS

GROUNDINGS

Ground	Location
G8	ENGINE COMPARTMENT / RH INNER WHEEL ARCH
G11	ENGINE COMPARTMENT / UNDER LH HEADLAMP ASSEMBLY
G17	ENGINE COMPARTMENT / ON GENERATOR BRACKET
G35	PASSENGER COMPARTMENT / LH LOWER E POST

FOR CONTROL MODULE PIN-OUT INFORMATION, UNFOLD PAGE TO LEFT.

The following abbreviations are used to represent values for Control Module Pin-Out data

I	Input	PG	Power Ground	CAN	CAN Network	D	Serial and Encoded Data
O	Output	SS	Sensor / Signal Supply V	SCP	SCP Network	V	Voltage (DC)
B+	Battery Voltage	SG	Sensor / Signal Ground	D2	D2B Network	PWM	Pulse Width Modulated

CAUTION: The information on this data page is furnished to aid the user in understanding circuit operation. THIS INFORMATION SHOULD BE USED FOR REFERENCE ONLY.

NOTE: The characteristics listed are approximately those that can be expected at the control module connector pins with all circuit connections made and all components connected and fitted.

Refer to the front of this book for detailed information and illustrations regarding the location and identification of harnesses, relays, fuses, grounds, control modules and control module pins.

CONTROL MODULE PIN-OUT INFORMATION

Transmission Control Module

Pin	Description and Characteristic
O JB131-03	2 / 4 BRAKE PRESSURE CONTROL SOLENOID DRIVE: PWM, 1.25 kHz, POSITIVE DUTY CYCLE 5 – 95%
O JB131-04	2 / 4 BRAKE TIMING SOLENOID DRIVE: B+ TO ACTIVATE
I JB131-05	OUTPUT SPEED SENSOR SIGNAL: 18 PULSES PER OUTPUT SHAFT REVOLUTION
B+ JB131-06	BATTERY POWER SUPPLY: B+
I JB131-07	RANGE SENSOR – 3: 3 = GROUND; NOT IN 3 = OPEN CIRCUIT
I JB131-08	RANGE SENSOR – 2: 2 = GROUND; NOT IN 2 = OPEN CIRCUIT
PG JB131-09	POWER GROUND: GROUND
O JB131-10	REDUCTION TIMING SOLENOID DRIVE: B+ TO ACTIVATE
C JB131-12	CAN – 1
C JB131-13	CAN – 2
O JB131-14	SHIFT SOLENOID B DRIVE: B+ TO ACTIVATE
O JB131-15	SHIFT SOLENOID A DRIVE: B+ TO ACTIVATE
O JB131-16	TCC PRESSURE CONTROL SOLENOID DRIVE: PWM, 1.25 kHz, POSITIVE DUTY CYCLE 5 – 95%
SG JB131-17	SOLENOID GROUND RETURN: GROUND
O JB131-18	LINE PRESSURE CONTROL SOLENOID DRIVE: PWM, 1.25 kHz, POSITIVE DUTY CYCLE 5 – 95%
SG JB131-20	SENSOR GROUND: GROUND
I JB131-21	INTERMEDIATE SPEED SENSOR SIGNAL: 54 PULSES PER INTERMEDIATE SHAFT REVOLUTION*
I JB131-24	TURBINE SPEED SENSOR SIGNAL: 36 PULSES PER ENGINE REVOLUTION
I JB131-25	RANGE SENSOR – N: N = GROUND; NOT IN N = OPEN CIRCUIT
I JB131-26	RANGE SENSOR – R: R = GROUND; NOT IN R = OPEN CIRCUIT
I JB131-27	RANGE SENSOR – D: D = GROUND; NOT IN D = OPEN CIRCUIT
I JB131-30	RANGE SENSOR – P: P = GROUND; NOT IN P = OPEN CIRCUIT
C JB131-33	CAN + 1
C JB131-34	CAN + 2
B+ JB131-36	IGNITION SWITCHED POWER SUPPLY: B+
PG JB131-38	POWER GROUND: GROUND
I JB131-39	FLUID TEMPERATURE SENSOR SIGNAL, NOMINAL 0 – 5 V: NTC SENSOR – VOLTAGE DECREASES AS TEMPERATURE INCREASES
I JB131-45	D – 4 SWITCH: SWITCH ACTIVATED = GROUND
I JB131-47	MODE SWITCH: "SPORT" SELECTED = GROUND
O JB131-52	SHIFT SOLENOID C DRIVE: B+ TO ACTIVATE
O JB131-53	LOW CLUTCH TIMING SOLENOID DRIVE: B+ TO ACTIVATE
B+ JB131-54	IGNITION SWITCHED POWER SUPPLY: B+

* IN 1ST – 4TH AND R, THE INTERMEDIATE SHAFT SPEED IS THE SAME AS THE OUTPUT SHAFT SPEED. IN 5TH, THE INTERMEDIATE SHAFT SPEED IS MULTIPLIED BY 1.2.

Engine Control Module (2.5L & 3.0L)

Pin	Description and Characteristic
SG EN16-019	SENSOR GROUND 1: GROUND
I EN16-026	MANUAL TRANSMISSION OUTPUT SPEED SENSOR SIGNAL: PULSED SIGNAL, 26 PULSES PER TRANSMISSION REVOLUTION
I EN16-031	CLUTCH PEDAL SAFETY SWITCH (MANUAL TRANSMISSION): NORMALLY OPEN / B+ WHEN ACTIVATED
I EN16-033	CLUTCH CANCEL SWITCH: NORMALLY CLOSED / GROUND WHEN ACTIVATED

NOTE: Refer to the Appendix at the rear of this book for Network Messages.

The following abbreviations are used to represent values for Control Module Pin-Out data

I	Input	PG	Power Ground	CAN	CAN Network	D	Serial and Encoded Data
O	Output	SS	Sensor / Signal Supply V	SCP	SCP Network	V	Voltage (DC)
B+	Battery Voltage	SG	Sensor / Signal Ground	D2	D2B Network	PWM	Pulse Width Modulated

CAUTION: The information on this data page is furnished to aid the user in understanding circuit operation. THIS INFORMATION SHOULD BE USED FOR REFERENCE ONLY.

NOTE: The characteristics listed are approximately those that can be expected at the control module connector pins with all circuit connections made and all components connected and fitted.

Fig. 04.1

COMPONENTS: Automatic Transmission

Component	Connector(s)	Connector Description	Location
AUTOMATIC TRANSMISSION	JB155	18-WAY / BLACK	ENGINE COMPARTMENT
IGNITION SWITCH	IP18	7-WAY / BLACK	STEERING COLUMN
J GATE ASSEMBLY	IP14	16-WAY / GREEN	CENTER CONSOLE
POWER DISTRIBUTION FUSE BOX	—	—	ENGINE COMPARTMENT LH SIDE
TCM RELAY	—	—	POWER DISTRIBUTION FUSE BOX R8
TRANSMISSION CONTROL MODULE	JB131	37-WAY / BLUE	LOWER LH A POST
TRANSMISSION RANGE SENSOR	JB156	10-WAY / BLACK	TOP OF TRANSMISSION

COMPONENTS: Manual Transmission

Component	Connector(s)	Connector Description	Location
CLUTCH CANCEL SWITCH	PA4	5-WAY / BLACK	TOP OF CLUTCH PEDAL
CLUTCH PEDAL SAFETY SWITCH	PA5	2-WAY / BLACK	TOP OF CLUTCH PEDAL
ENGINE CONTROL MODULE (2.5L & 3.0L)	EN16	134-WAY / BLACK	ENGINE COMPARTMENT, FRONT BULKHEAD RH SIDE
OUTPUT SPEED SENSOR	EN86	3-WAY / BLACK	DIFFERENTIAL OUTPUT SHAFT HOUSING
REVERSE LAMPS SWITCH	EN85	2-WAY / BLACK	TOP OF TRANSMISSION

HARNESS IN-LINE CONNECTORS

Connector	Connector Description	Location
JB1	42-WAY / BLACK / JUNCTION BOX HARNESS TO ENGINE HARNESS	ADJACENT TO LH SUSPENSION TURRET
JB2	16-WAY / GREEN / JUNCTION BOX HARNESS TO CABIN HARNESS	ADJACENT TO CENTRAL JUNCTION FUSE BOX
JB129	22-WAY / GREY / INSTRUMENT PANEL HARNESS TO JUNCTION BOX HARNESS	LH LOWER A POST
JB130	22-WAY / GREEN / JUNCTION BOX HARNESS TO INSTRUMENT PANEL HARNESS	ADJACENT TO CENTRAL JUNCTION FUSE BOX
JB145	8-WAY / BLACK / ENGINE HARNESS TO JUNCTION BOX HARNESS	ADJACENT TO CENTRAL JUNCTION FUSE BOX

GROUND

Ground	Location
G14	ENGINE COMPARTMENT / REARWARD OF POWER DISTRIBUTION FUSE BOX
G15	PASSENGER COMPARTMENT / LH LOWER A POST
G37	PASSENGER COMPARTMENT / LH CROSS CAR BEAM

FOR CONTROL MODULE PIN-OUT INFORMATION, UNFOLD PAGE TO LEFT.

Refer to the front of this book for detailed information and illustrations regarding the location and identification of harnesses, relays, fuses, grounds, control modules and control module pins.

CONTROL MODULE PIN-OUT INFORMATION

Fig. 04.2

Transmission Control Module

Pin	Description and Characteristic
O JB131-03	2 / 4 BRAKE PRESSURE CONTROL SOLENOID DRIVE: PWM, 1.25 kHz, POSITIVE DUTY CYCLE 5 – 95%
O JB131-04	2 / 4 BRAKE TIMING SOLENOID DRIVE: B+ TO ACTIVATE
I JB131-05	OUTPUT SPEED SENSOR SIGNAL: 18 PULSES PER OUTPUT SHAFT REVOLUTION
B+ JB131-06	BATTERY POWER SUPPLY: B+
I JB131-07	RANGE SENSOR – 3: 3 = GROUND; NOT IN 3 = OPEN CIRCUIT
I JB131-08	RANGE SENSOR – 2: 2 = GROUND; NOT IN 2 = OPEN CIRCUIT
PG JB131-09	POWER GROUND: GROUND
O JB131-10	REDUCTION TIMING SOLENOID DRIVE: B+ TO ACTIVATE
C JB131-12	CAN – 1
C JB131-13	CAN – 2
O JB131-14	SHIFT SOLENOID B DRIVE: B+ TO ACTIVATE
O JB131-15	SHIFT SOLENOID A DRIVE: B+ TO ACTIVATE
O JB131-16	TCC PRESSURE CONTROL SOLENOID DRIVE: PWM, 1.25 kHz, POSITIVE DUTY CYCLE 5 – 95%
SG JB131-17	SOLENOID GROUND RETURN: GROUND
O JB131-18	LINE PRESSURE CONTROL SOLENOID DRIVE: PWM, 1.25 kHz, POSITIVE DUTY CYCLE 5 – 95%
SG JB131-20	SENSOR GROUND: GROUND
I JB131-21	INTERMEDIATE SPEED SENSOR SIGNAL: 54 PULSES PER INTERMEDIATE SHAFT REVOLUTION*
I JB131-24	TURBINE SPEED SENSOR SIGNAL: 36 PULSES PER ENGINE REVOLUTION
I JB131-25	RANGE SENSOR – N: N = GROUND; NOT IN N = OPEN CIRCUIT
I JB131-26	RANGE SENSOR – R: R = GROUND; NOT IN R = OPEN CIRCUIT
I JB131-27	RANGE SENSOR – D: D = GROUND; NOT IN D = OPEN CIRCUIT
I JB131-30	RANGE SENSOR – P: P = GROUND; NOT IN P = OPEN CIRCUIT
C JB131-33	CAN + 1
C JB131-34	CAN + 2
B+ JB131-36	IGNITION SWITCHED POWER SUPPLY: B+
PG JB131-38	POWER GROUND: GROUND
I JB131-39	FLUID TEMPERATURE SENSOR SIGNAL, NOMINAL 0 – 5 V: NTC SENSOR – VOLTAGE DECREASES AS TEMPERATURE INCREASES
SG JB131-42	SENSOR GROUND: GROUND
SG JB131-44	SENSOR GROUND: GROUND
I JB131-45	D – 4 SWITCH: SWITCH ACTIVATED = GROUND
SG JB131-46	SENSOR GROUND: GROUND
I JB131-47	MODE SWITCH: "SPORT" SELECTED = GROUND
O JB131-52	SHIFT SOLENOID C DRIVE: B+ TO ACTIVATE
O JB131-53	LOW CLUTCH TIMING SOLENOID DRIVE: B+ TO ACTIVATE
B+ JB131-54	IGNITION SWITCHED POWER SUPPLY: B+

* IN 1ST – 4TH AND R, THE INTERMEDIATE SHAFT SPEED IS THE SAME AS THE OUTPUT SHAFT SPEED. IN 5TH, THE INTERMEDIATE SHAFT SPEED IS MULTIPLIED BY 1.2.

Engine Control Module (2.0L)

Pin	Description and Characteristic
I EN65-084	CLUTCH CANCEL SWITCH: NORMALLY CLOSED / GROUND WHEN ACTIVATED
I EN65-085	CLUTCH SAFETY CIRCUIT (MANUAL TRANSMISSION): B+

Engine Control Module (2.5L & 3.0L)

Pin	Description and Characteristic
I EN16-031	CLUTCH PEDAL SAFETY SWITCH (MANUAL TRANSMISSION): NORMALLY OPEN / B+ WHEN ACTIVATED
I EN16-033	CLUTCH CANCEL SWITCH: NORMALLY CLOSED / GROUND WHEN ACTIVATED

NOTE: Refer to the Appendix at the rear of this book for Network Messages.

The following abbreviations are used to represent values for Control Module Pin-Out data

I	Input	PG	Power Ground	CAN	CAN Network	D	Serial and Encoded Data
O	Output	SS	Sensor / Signal Supply V	SCP	SCP Network	V	Voltage (DC)
B+	Battery Voltage	SG	Sensor / Signal Ground	D2	D2B Network	PWM	Pulse Width Modulated

CAUTION: The information on this data page is furnished to aid the user in understanding circuit operation. THIS INFORMATION SHOULD BE USED FOR REFERENCE ONLY.

NOTE: The characteristics listed are approximately those that can be expected at the control module connector pins with all circuit connections made and all components connected and fitted.

COMPONENTS: Automatic Transmission

Component	Connector(s)	Connector Description	Location
AUTOMATIC TRANSMISSION	JB155	18-WAY / BLACK	ENGINE COMPARTMENT
IGNITION SWITCH	IP18	7-WAY / BLACK	STEERING COLUMN
J GATE ASSEMBLY	IP14	16-WAY / GREEN	CENTER CONSOLE
POWER DISTRIBUTION FUSE BOX	—	—	ENGINE COMPARTMENT LH SIDE
TCM RELAY	—	—	POWER DISTRIBUTION FUSE BOX R8
TRANSMISSION CONTROL MODULE	JB131	37-WAY / BLUE	LOWER LH A POST
TRANSMISSION RANGE SENSOR	JB156	10-WAY / BLACK	TOP OF TRANSMISSION

COMPONENTS: Manual Transmission

Component	Connector(s)	Connector Description	Location
CLUTCH CANCEL SWITCH	PA4	5-WAY / BLACK	TOP OF CLUTCH PEDAL
CLUTCH PEDAL SAFETY SWITCH	PA5	2-WAY / BLACK	TOP OF CLUTCH PEDAL
ENGINE CONTROL MODULE (2.0L)	EN65	104-WAY / BLACK	ENGINE COMPARTMENT, FRONT BULKHEAD RH SIDE
ENGINE CONTROL MODULE (2.5L & 3.0L)	EN16	134-WAY / BLACK	ENGINE COMPARTMENT, FRONT BULKHEAD RH SIDE
REVERSE LAMPS SWITCH	EN85	2-WAY / BLACK	TOP OF TRANSMISSION

HARNESS IN-LINE CONNECTORS

Connector	Connector Description	Location
JB1	42-WAY / BLACK / JUNCTION BOX HARNESS TO ENGINE HARNESS	ADJACENT TO LH SUSPENSION TURRET
JB2	16-WAY / GREEN / JUNCTION BOX HARNESS TO CABIN HARNESS	ADJACENT TO CENTRAL JUNCTION FUSE BOX
JB129	22-WAY / GREY / INSTRUMENT PANEL HARNESS TO JUNCTION BOX HARNESS	LH LOWER A POST
JB130	22-WAY / GREEN / JUNCTION BOX HARNESS TO INSTRUMENT PANEL HARNESS	ADJACENT TO CENTRAL JUNCTION FUSE BOX
JB145	8-WAY / BLACK / ENGINE HARNESS TO JUNCTION BOX HARNESS	ADJACENT TO CENTRAL JUNCTION FUSE BOX

GROUND

Ground	Location
G14	ENGINE COMPARTMENT / REARWARD OF POWER DISTRIBUTION FUSE BOX
G15	PASSENGER COMPARTMENT / LH LOWER A POST
G37	PASSENGER COMPARTMENT / LH CROSS CAR BEAM

FOR CONTROL MODULE PIN-OUT INFORMATION, UNFOLD PAGE TO LEFT.

Refer to the front of this book for detailed information and illustrations regarding the location and identification of harnesses, relays, fuses, grounds, control modules and control module pins.

CONTROL MODULE PIN-OUT INFORMATION

Transmission Control Module

Pin	Description and Characteristic
O JB131-03	2 / 4 BRAKE PRESSURE CONTROL SOLENOID DRIVE: PWM, 1.25 kHz, POSITIVE DUTY CYCLE 5 – 95%
O JB131-04	2 / 4 BRAKE TIMING SOLENOID DRIVE: B+ TO ACTIVATE
I JB131-05	OUTPUT SPEED SENSOR SIGNAL: 18 PULSES PER OUTPUT SHAFT REVOLUTION
B+ JB131-06	BATTERY POWER SUPPLY: B+
I JB131-07	RANGE SENSOR – 3: 3 = GROUND; NOT IN 3 = OPEN CIRCUIT
I JB131-08	RANGE SENSOR – 2: 2 = GROUND; NOT IN 2 = OPEN CIRCUIT
PG JB131-09	POWER GROUND: GROUND
O JB131-10	REDUCTION TIMING SOLENOID DRIVE: B+ TO ACTIVATE
C JB131-12	CAN – 1
C JB131-13	CAN – 2
O JB131-14	SHIFT SOLENOID B DRIVE: B+ TO ACTIVATE
O JB131-15	SHIFT SOLENOID A DRIVE: B+ TO ACTIVATE
O JB131-16	TCC PRESSURE CONTROL SOLENOID DRIVE: PWM, 1.25 kHz, POSITIVE DUTY CYCLE 5 – 95%
SG JB131-17	SOLENOID GROUND RETURN: GROUND
O JB131-18	LINE PRESSURE CONTROL SOLENOID DRIVE: PWM, 1.25 kHz, POSITIVE DUTY CYCLE 5 – 95%
SG JB131-20	SENSOR GROUND: GROUND
I JB131-21	INTERMEDIATE SPEED SENSOR SIGNAL: 54 PULSES PER INTERMEDIATE SHAFT REVOLUTION*
I JB131-24	TURBINE SPEED SENSOR SIGNAL: 36 PULSES PER ENGINE REVOLUTION
I JB131-25	RANGE SENSOR – N: N = GROUND; NOT IN N = OPEN CIRCUIT
I JB131-26	RANGE SENSOR – R: R = GROUND; NOT IN R = OPEN CIRCUIT
I JB131-27	RANGE SENSOR – D: D = GROUND; NOT IN D = OPEN CIRCUIT
I JB131-30	RANGE SENSOR – P: P = GROUND; NOT IN P = OPEN CIRCUIT
C JB131-33	CAN + 1
C JB131-34	CAN + 2
B+ JB131-36	IGNITION SWITCHED POWER SUPPLY: B+
PG JB131-38	POWER GROUND: GROUND
I JB131-39	FLUID TEMPERATURE SENSOR SIGNAL, NOMINAL 0 – 5 V: NTC SENSOR – VOLTAGE DECREASES AS TEMPERATURE INCREASES
SG JB131-42	SENSOR GROUND: GROUND
SG JB131-44	SENSOR GROUND: GROUND
I JB131-45	D – 4 SWITCH: SWITCH ACTIVATED = GROUND
SG JB131-46	SENSOR GROUND: GROUND
I JB131-47	MODE SWITCH: "SPORT" SELECTED = GROUND
O JB131-52	SHIFT SOLENOID C DRIVE: B+ TO ACTIVATE
O JB131-53	LOW CLUTCH TIMING SOLENOID DRIVE: B+ TO ACTIVATE
B+ JB131-54	IGNITION SWITCHED POWER SUPPLY: B+

* IN 1ST – 4TH AND R, THE INTERMEDIATE SHAFT SPEED IS THE SAME AS THE OUTPUT SHAFT SPEED. IN 5TH, THE INTERMEDIATE SHAFT SPEED IS MULTIPLIED BY 1.2.

Engine Control Module (2.0L)

Pin	Description and Characteristic
I EN65-084	CLUTCH CANCEL SWITCH: NORMALLY CLOSED / GROUND WHEN ACTIVATED
I EN65-085	CLUTCH SAFETY CIRCUIT (MANUAL TRANSMISSION): B+

Engine Control Module (2.5L & 3.0L)

Pin	Description and Characteristic
I EN16-031	CLUTCH PEDAL SAFETY SWITCH (MANUAL TRANSMISSION): NORMALLY OPEN / B+ WHEN ACTIVATED
I EN16-033	CLUTCH CANCEL SWITCH: NORMALLY CLOSED / GROUND WHEN ACTIVATED

NOTE: Refer to the Appendix at the rear of this book for Network Messages.

The following abbreviations are used to represent values for Control Module Pin-Out data

I	Input	PG	Power Ground	CAN	CAN Network	D	Serial and Encoded Data
O	Output	SS	Sensor / Signal Supply V	SCP	SCP Network	V	Voltage (DC)
B+	Battery Voltage	SG	Sensor / Signal Ground	D2	D2B Network	PWM	Pulse Width Modulated

CAUTION: The information on this data page is furnished to aid the user in understanding circuit operation. THIS INFORMATION SHOULD BE USED FOR REFERENCE ONLY.

NOTE: The characteristics listed are approximately those that can be expected at the control module connector pins with all circuit connections made and all components connected and fitted.

Fig. 04.3

COMPONENTS: Automatic Transmission

Component	Connector(s)	Connector Description	Location
AUTOMATIC TRANSMISSION	JB155	18-WAY / BLACK	ENGINE COMPARTMENT
IGNITION SWITCH	IP18	7-WAY / BLACK	STEERING COLUMN
J GATE ASSEMBLY	IP14	16-WAY / GREEN	CENTER CONSOLE
POWER DISTRIBUTION FUSE BOX	—	—	ENGINE COMPARTMENT LH SIDE
TCM RELAY	—	—	POWER DISTRIBUTION FUSE BOX R8
TRANSMISSION CONTROL MODULE	JB131	37-WAY / BLUE	LOWER LH A POST
TRANSMISSION RANGE SENSOR	JB156	10-WAY / BLACK	TOP OF TRANSMISSION

COMPONENTS: Manual Transmission

Component	Connector(s)	Connector Description	Location
CLUTCH CANCEL SWITCH	PA4	5-WAY / BLACK	TOP OF CLUTCH PEDAL
CLUTCH PEDAL SAFETY SWITCH	PA5	2-WAY / BLACK	TOP OF CLUTCH PEDAL
ENGINE CONTROL MODULE (2.0L)	EN65	104-WAY / BLACK	ENGINE COMPARTMENT, FRONT BULKHEAD RH SIDE
ENGINE CONTROL MODULE (2.5L & 3.0L)	EN16	134-WAY / BLACK	ENGINE COMPARTMENT, FRONT BULKHEAD RH SIDE
REVERSE LAMPS SWITCH	EN85	2-WAY / BLACK	TOP OF TRANSMISSION

HARNESS IN-LINE CONNECTORS

Connector	Connector Description	Location
JB1	42-WAY / BLACK / JUNCTION BOX HARNESS TO ENGINE HARNESS	ADJACENT TO LH SUSPENSION TURRET
JB2	16-WAY / GREEN / JUNCTION BOX HARNESS TO CABIN HARNESS	ADJACENT TO CENTRAL JUNCTION FUSE BOX
JB129	22-WAY / GREY / INSTRUMENT PANEL HARNESS TO JUNCTION BOX HARNESS	LH LOWER A POST
JB130	22-WAY / GREEN / JUNCTION BOX HARNESS TO INSTRUMENT PANEL HARNESS	ADJACENT TO CENTRAL JUNCTION FUSE BOX
JB145	8-WAY / BLACK / ENGINE HARNESS TO JUNCTION BOX HARNESS	ADJACENT TO CENTRAL JUNCTION FUSE BOX

GROUNDINGS

Ground	Location
G14	ENGINE COMPARTMENT / REARWARD OF POWER DISTRIBUTION FUSE BOX
G15	PASSENGER COMPARTMENT / LH LOWER A POST
G37	PASSENGER COMPARTMENT / LH CROSS CAR BEAM

FOR CONTROL MODULE PIN-OUT INFORMATION, UNFOLD PAGE TO LEFT.

Refer to the front of this book for detailed information and illustrations regarding the location and identification of harnesses, relays, fuses, grounds, control modules and control module pins.

Anti-Lock Braking Control Module

Pin	Description and Characteristic
PG	JB45-01 MOTOR GROUND: GROUND
B+	JB45-02 BATTERY POWER SUPPLY – MOTOR: B+
PG	JB45-05 POWER GROUND: GROUND
B+	JB45-06 BATTERY POWER SUPPLY: B+
I	JB45-12 LH FRONT WHEEL SPEED SENSOR SIGNAL: 32 PULSES PER WHEEL REVOLUTION
SS	JB45-13 LH REAR WHEEL SPEED SENSOR SUPPLY VOLTAGE: B+
I	JB45-14 LH REAR WHEEL SPEED SENSOR SIGNAL: 32 PULSES PER WHEEL REVOLUTION
SS	JB45-15 RH FRONT WHEEL SPEED SENSOR SUPPLY VOLTAGE: B+
I	JB45-16 RH FRONT WHEEL SPEED SENSOR SIGNAL: 32 PULSES PER WHEEL REVOLUTION
B+	JB45-23 IGNITION SWITCHED POWER SUPPLY: B+
C	JB45-24 CAN +
O	JB45-28 LH FRONT WHEEL SPEED SENSOR SUPPLY VOLTAGE: B+
O	JB45-30 RH REAR WHEEL SPEED SENSOR SUPPLY VOLTAGE: B+
I	JB45-31 RH REAR WHEEL SPEED SENSOR SIGNAL: 32 PULSES PER WHEEL REVOLUTION
I	JB45-32 BRAKE ON / OFF SWITCH: NORMALLY OPEN / B+ WHEN ACTIVATED
C	JB45-40 CAN –

NOTE: Refer to the Appendix at the rear of this book for Network Messages.

COMPONENTS

Component	Connector(s)	Connector Description	Location
ANTI-LOCK BRAKING SYSTEM CONTROL MODULE	JB45	42-WAY / BROWN	ENGINE COMPARTMENT RH SIDE
BRAKE ON / OFF SWITCH	PA3	3-WAY / BLACK	TOP OF BRAKE PEDAL
CAPACITOR (ABS / DSC)	JB195	2-WAY	ADJACENT TO MODULATOR
CENTRAL JUNCTION FUSE BOX	CA75 CA76 CA77 CA78	8-WAY / GREY 16-WAY / GREEN 2-WAY / GREY 16-WAY / GREY	PASSENGER COMPARTMENT, FRONT BULKHEAD LH SIDE
	IP1 IP2 IP3 IP4	14-WAY / GREEN 16-WAY / GREY 2-WAY / GREY 14-WAY / GREY	
	JB50 JB51 JB52	4-WAY / GREY 16-WAY / BLUE 2-WAY / BLACK	
VACUUM MODULE	VM1 VM2 VM3	— — —	UNDER BATTERY TRAY
VACUUM PUMP	VPU	—	ADJACENT TO BRAKE SERVO
WHEEL SPEED SENSOR – LH FRONT	LF1	2-WAY / BLACK	LH FRONT WHEEL HUB
WHEEL SPEED SENSOR – LH REAR	CA55	2-WAY / BLACK	LH REAR WHEEL HUB
WHEEL SPEED SENSOR – RH FRONT	RF1	2-WAY / BLACK	RH FRONT WHEEL HUB
WHEEL SPEED SENSOR – RH REAR	CA60	2-WAY / BLACK	RH REAR WHEEL HUB

HARNESS IN-LINE CONNECTORS

Connector	Connector Description	Location
CA10	22-WAY / GREY / ENGINE HARNESS TO CABIN HARNESS	BELOW THE GLOVEBOX
CA170	16-WAY / GREEN / IN-LINE CONNECTOR	LH LOWER A POST
JB2	16-WAY / GREEN / JUNCTION BOX HARNESS TO CABIN HARNESS	ADJACENT TO CENTRAL JUNCTION FUSE BOX
JB15	2-WAY / BLACK / ABS LINK LEAD	BEHIND FRONT LH WHEELARCH LINER
JB133	2-WAY / BLACK / ABS LINK LEAD	BEHIND LH WHEELARCH LINER
VP1	2-WAY / VACUUM PUMP LINK LEAD	ENGINE COMPARTMENT, LH REAR

GROUND

Ground	Location
G14	ENGINE COMPARTMENT / REARWARD OF POWER DISTRIBUTION FUSE BOX
G18	ENGINE COMPARTMENT / UNDER RH HEADLAMP ASSEMBLY

FOR CONTROL MODULE PIN-OUT INFORMATION, UNFOLD PAGE TO LEFT.

The following abbreviations are used to represent values for Control Module Pin-Out data

I	Input	PG	Power Ground	CAN	CAN Network	D	Serial and Encoded Data
O	Output	SS	Sensor / Signal Supply V	SCP	SCP Network	V	Voltage (DC)
B+	Battery Voltage	SG	Sensor / Signal Ground	D2	D2B Network	PWM	Pulse Width Modulated

CAUTION: The information on this data page is furnished to aid the user in understanding circuit operation. THIS INFORMATION SHOULD BE USED FOR REFERENCE ONLY.

NOTE: The characteristics listed are approximately those that can be expected at the control module connector pins with all circuit connections made and all components connected and fitted.

Refer to the front of this book for detailed information and illustrations regarding the location and identification of harnesses, relays, fuses, grounds, control modules and control module pins.

Dynamic Stability Control Control Module

Pin	Description and Characteristic
PG	JB185-01 MOTOR GROUND: GROUND
B+	JB185-02 BATTERY POWER SUPPLY – MOTOR: B+
PG	JB185-05 POWER GROUND: GROUND
B+	JB185-06 BATTERY POWER SUPPLY: B+
I	JB185-12 LH FRONT WHEEL SPEED SENSOR SIGNAL: 32 PULSES PER WHEEL REVOLUTION
SS	JB185-13 LH REAR WHEEL SPEED SENSOR SUPPLY VOLTAGE: B+
I	JB185-14 LH REAR WHEEL SPEED SENSOR SIGNAL: 32 PULSES PER WHEEL REVOLUTION
SS	JB185-15 RH FRONT WHEEL SPEED SENSOR SUPPLY VOLTAGE: B+
I	JB185-16 RH FRONT WHEEL SPEED SENSOR SIGNAL: 32 PULSES PER WHEEL REVOLUTION
SG	JB185-21 SENSOR GROUND – YAW RATE, STEERING ANGLE SENSORS: GROUND
B+	JB185-23 IGNITION SWITCHED POWER SUPPLY: B+
C	JB185-24 CAN +
SG	JB185-25 SENSOR GROUND – BRAKE PRESSURE SENSOR: GROUND
I	JB185-26 BRAKE PRESSURE SENSOR SIGNAL, NOMINAL 0 – 5 V: VOLTAGE INCREASES AS PRESSURE INCREASES
I	JB185-27 DYNAMIC STABILITY CONTROL SWITCH: NORMALLY OPEN / GROUND WHEN ACTIVATED
O	JB185-28 LH FRONT WHEEL SPEED SENSOR SUPPLY VOLTAGE: B+
O	JB185-30 RH REAR WHEEL SPEED SENSOR SUPPLY VOLTAGE: B+
I	JB185-31 RH REAR WHEEL SPEED SENSOR SIGNAL: 32 PULSES PER WHEEL REVOLUTION
I	JB185-32 BRAKE ON / OFF SWITCH: NORMALLY OPEN / B+ WHEN ACTIVATED
SS	JB185-39 YAW RATE, STEERING ANGLE SENSORS SUPPLY VOLTAGE: B+
C	JB185-40 CAN –
SS	JB185-42 BRAKE PRESSURE SENSOR SUPPLY VOLTAGE: NOMINAL 5 V

NOTE: Refer to the Appendix at the rear of this book for Network Messages.

COMPONENTS

Component	Connector(s)	Connector Description	Location
BRAKE ON / OFF SWITCH	PA3	3-WAY / BLACK	TOP OF BRAKE PEDAL
BRAKE PRESSURE SENSOR	JB89	3-WAY / BLACK	ON DYNAMIC STABILITY CONTROL MODULATOR
CAPACITOR (ABS / DSC)	JB195	2-WAY	ADJACENT TO MODULATOR
CENTRAL JUNCTION FUSE BOX	CA75 CA76 CA77 CA78	8-WAY / GREY 16-WAY / GREEN 2-WAY / GREY 16-WAY / GREY	PASSENGER COMPARTMENT, FRONT BULKHEAD LH SIDE
	IP1	14-WAY / GREEN	
	IP2	16-WAY / GREY	
	IP3	2-WAY / GREY	
	IP4	14-WAY / GREY	
	JB50	4-WAY / GREY	
	JB51	16-WAY / BLUE	
	JB52	2-WAY / BLACK	
DYNAMIC STABILITY CONTROL CONTROL MODULE	JB185	42-WAY / BLUE	ENGINE COMPARTMENT RH SIDE
DYNAMIC STABILITY CONTROL SWITCH	IP29	6-WAY / BLACK	INSTRUMENT PANEL
STEERING ANGLE SENSOR	IP19	4-WAY / BLACK	STEERING COLUMN
VACUUM MODULE	VM1 VM2 VM3	— — —	UNDER BATTERY TRAY
VACUUM PUMP	VPU	—	ADJACENT TO BRAKE SERVO
WHEEL SPEED SENSOR – LH FRONT (ALL)	LF1	2-WAY / BLACK	LH FRONT WHEEL HUB
WHEEL SPEED SENSOR – LH REAR (2.5L & 3.0L)	CA55	2-WAY / BLACK	LH REAR WHEEL HUB
WHEEL SPEED SENSOR – LH REAR (2.0L)	LR1	2-WAY / BLACK	LH REAR WHEEL HUB
WHEEL SPEED SENSOR – RH FRONT (ALL)	RF1	2-WAY / BLACK	RH FRONT WHEEL HUB
WHEEL SPEED SENSOR – RH REAR (2.5L & 3.0L)	CA60	2-WAY / BLACK	RH REAR WHEEL HUB
WHEEL SPEED SENSOR – RH REAR (2.0L)	RR1	2-WAY / BLACK	RH REAR WHEEL HUB
YAW RATE SENSOR	IP20	4-WAY / BLACK	BEHIND CENTER CONSOLE

HARNESS IN-LINE CONNECTORS

Connector	Connector Description	Location
CA10	22-WAY / GREY / ENGINE HARNESS TO CABIN HARNESS	BELOW THE GLOVEBOX
CA55	2-WAY / BLACK / 2.0L LH REAR WHEEL SPEED SENSOR LINK LEAD	LH REAR WHEEL HUB
CA60	2-WAY / BLACK / 2.0L RH REAR WHEEL SPEED SENSOR LINK LEAD	RH REAR WHEEL HUB
CA170	16-WAY / GREEN / IN-LINE CONNECTOR	LH LOWER A POST
JB2	16-WAY / GREEN / JUNCTION BOX HARNESS TO CABIN HARNESS	ADJACENT TO CENTRAL JUNCTION FUSE BOX
JB15	2-WAY / BLACK / ABS LINK LEAD	BEHIND FRONT LH WHEELARCH LINER
JB129	22-WAY / GREY / INSTRUMENT PANEL HARNESS TO JUNCTION BOX HARNESS	LH LOWER A POST
JB130	22-WAY / GREEN / JUNCTION BOX HARNESS TO INSTRUMENT PANEL HARNESS	ADJACENT TO CENTRAL JUNCTION FUSE BOX
JB133	2-WAY / BLACK / ABS LINK LEAD	BEHIND LH WHEELARCH LINER
JB196	10-WAY / GREY / JUNCTION BOX HARNESS TO CABIN HARNESS	ADJACENT TO FOOT PEDALS
VP1	2-WAY / VACUUM PUMP LINK LEAD	ENGINE COMPARTMENT, LH REAR

GROUND

Ground	Location
G14	ENGINE COMPARTMENT / REARWARD OF POWER DISTRIBUTION FUSE BOX
G18	ENGINE COMPARTMENT / UNDER RH HEADLAMP ASSEMBLY
G37	PASSENGER COMPARTMENT / LH CROSS CAR BEAM

FOR CONTROL MODULE PIN-OUT INFORMATION, UNFOLD PAGE TO LEFT.

The following abbreviations are used to represent values for Control Module Pin-Out data

I	Input	PG	Power Ground	CAN	CAN Network	D	Serial and Encoded Data
O	Output	SS	Sensor / Signal Supply V	SCP	SCP Network	V	Voltage (DC)
B+	Battery Voltage	SG	Sensor / Signal Ground	D2	D2B Network	PWM	Pulse Width Modulated

CAUTION: The information on this data page is furnished to aid the user in understanding circuit operation. THIS INFORMATION SHOULD BE USED FOR REFERENCE ONLY.

NOTE: The characteristics listed are approximately those that can be expected at the control module connector pins with all circuit connections made and all components connected and fitted.

Refer to the front of this book for detailed information and illustrations regarding the location and identification of harnesses, relays, fuses, grounds, control modules and control module pins.

Anti-Lock Braking Control Module

Pin	Description and Characteristic
PG	JB197-01 MOTOR GROUND: GROUND
B+	JB197-02 BATTERY POWER SUPPLY – MOTOR: B+
PG	JB197-05 POWER GROUND: GROUND
B+	JB197-06 BATTERY POWER SUPPLY: B+
I	JB197-12 LH FRONT WHEEL SPEED SENSOR SIGNAL: 32 PULSES PER WHEEL REVOLUTION
SS	JB197-13 LH REAR WHEEL SPEED SENSOR SUPPLY VOLTAGE: B+
I	JB197-14 LH REAR WHEEL SPEED SENSOR SIGNAL: 32 PULSES PER WHEEL REVOLUTION
SS	JB197-15 RH FRONT WHEEL SPEED SENSOR SUPPLY VOLTAGE: B+
I	JB197-16 RH FRONT WHEEL SPEED SENSOR SIGNAL: 32 PULSES PER WHEEL REVOLUTION
B+	JB197-23 IGNITION SWITCHED POWER SUPPLY: B+
C	JB197-24 CAN +
I	JB197-27 TRACTION CONTROL SWITCH: NORMALLY OPEN / GROUND WHEN ACTIVATED
O	JB197-28 LH FRONT WHEEL SPEED SENSOR SUPPLY VOLTAGE: B+
O	JB197-30 RH REAR WHEEL SPEED SENSOR SUPPLY VOLTAGE: B+
I	JB197-31 RH REAR WHEEL SPEED SENSOR SIGNAL: 32 PULSES PER WHEEL REVOLUTION
I	JB197-32 BRAKE ON / OFF SWITCH: NORMALLY OPEN / B+ WHEN ACTIVATED
C	JB197-40 CAN –

NOTE: Refer to the Appendix at the rear of this book for Network Messages.

COMPONENTS

Component	Connector(s)	Connector Description	Location
ANTI-LOCK BRAKING / TRACTION CONTROL CONTROL MODULE	JB197	42-WAY / BROWN	ENGINE COMPARTMENT RH SIDE
BRAKE ON / OFF SWITCH	PA3	3-WAY / BLACK	TOP OF BRAKE PEDAL
CAPACITOR (ABS / DSC)	JB195	2-WAY	ADJACENT TO MODULATOR
CENTRAL JUNCTION FUSE BOX	CA75 CA76 CA77 CA78	8-WAY / GREY 16-WAY / GREEN 2-WAY / GREY 16-WAY / GREY	PASSENGER COMPARTMENT, FRONT BULKHEAD LH SIDE
	IP1 IP2 IP3 IP4	14-WAY / GREEN 16-WAY / GREY 2-WAY / GREY 14-WAY / GREY	
	JB50 JB51 JB52	4-WAY / GREY 16-WAY / BLUE 2-WAY / BLACK	
TRACTION CONTROL SWITCH	IP29	6-WAY / BLACK	INSTRUMENT PANEL
VACUUM MODULE	VM1 VM2 VM3	— — —	UNDER BATTERY TRAY
VACUUM PUMP	VPU	—	ADJACENT TO BRAKE SERVO
WHEEL SPEED SENSOR – LH FRONT	LF1	2-WAY / BLACK	LH FRONT WHEEL HUB
WHEEL SPEED SENSOR – LH REAR	LR1	2-WAY / BLACK	LH REAR WHEEL HUB
WHEEL SPEED SENSOR – RH FRONT	RF1	2-WAY / BLACK	RH FRONT WHEEL HUB
WHEEL SPEED SENSOR – RH REAR	RR1	2-WAY / BLACK	RH REAR WHEEL HUB

HARNES IN-LINE CONNECTORS

Connector	Connector Description	Location
CA10	22-WAY / GREY / ENGINE HARNESS TO CABIN HARNESS	BELOW THE GLOVEBOX
CA55	2-WAY / BLACK / 2.0L LH REAR WHEEL SPEED SENSOR LINK LEAD	LH REAR WHEEL HUB
CA60	2-WAY / BLACK / 2.0L RH REAR WHEEL SPEED SENSOR LINK LEAD	RH REAR WHEEL HUB
CA170	16-WAY / GREEN / IN-LINE CONNECTOR	LH LOWER A POST
JB15	2-WAY / BLACK / ABS LINK LEAD	BEHIND FRONT LH WHEELARCH LINER
JB130	22-WAY / GREEN / JUNCTION BOX HARNESS TO INSTRUMENT PANEL HARNESS	ADJACENT TO CENTRAL JUNCTION FUSE BOX
JB133	2-WAY / BLACK / ABS LINK LEAD	BEHIND LH WHEELARCH LINER
JB196	10-WAY / GREY / JUNCTION BOX HARNESS TO CABIN HARNESS	ADJACENT TO FOOT PEDALS
VP1	2-WAY / VACUUM PUMP LINK LEAD	ENGINE COMPARTMENT, LH REAR

GROUND

Ground	Location
G14	ENGINE COMPARTMENT / REARWARD OF POWER DISTRIBUTION FUSE BOX
G18	ENGINE COMPARTMENT / UNDER RH HEADLAMP ASSEMBLY
G37	PASSENGER COMPARTMENT / LH CROSS CAR BEAM

FOR CONTROL MODULE PIN-OUT INFORMATION, UNFOLD PAGE TO LEFT.

The following abbreviations are used to represent values for Control Module Pin-Out data

I	Input	PG	Power Ground	CAN	CAN Network	D	Serial and Encoded Data
O	Output	SS	Sensor / Signal Supply V	SCP	SCP Network	V	Voltage (DC)
B+	Battery Voltage	SG	Sensor / Signal Ground	D2	D2B Network	PWM	Pulse Width Modulated

CAUTION: The information on this data page is furnished to aid the user in understanding circuit operation. THIS INFORMATION SHOULD BE USED FOR REFERENCE ONLY.

NOTE: The characteristics listed are approximately those that can be expected at the control module connector pins with all circuit connections made and all components connected and fitted.

Refer to the front of this book for detailed information and illustrations regarding the location and identification of harnesses, relays, fuses, grounds, control modules and control module pins.

CONTROL MODULE PIN-OUT INFORMATION

Air Conditioning Control Module: Manual

Pin	Description and Characteristic
O	AC1-04 FRESH / RECIRCULATION FLAP ACTUATOR DRIVE: TO ACTIVATE, A/CCM SWITCHES CIRCUIT TO B+ OR TO GROUND
O	AC1-05 FRESH / RECIRCULATION FLAP ACTUATOR DRIVE: TO ACTIVATE, A/CCM SWITCHES CIRCUIT TO B+ OR TO GROUND
O	AC1-06 DEFROST DOOR ACTUATOR STEPPER COIL 1 DRIVE: TO ACTIVATE, A/CCM SWITCHES CIRCUIT TO GROUND
O	AC1-07 DEFROST DOOR ACTUATOR STEPPER COIL 2 DRIVE: TO ACTIVATE, A/CCM SWITCHES CIRCUIT TO GROUND
O	AC1-08 PANEL / FLOOR ACTUATOR STEPPER COIL 1 DRIVE: TO ACTIVATE, A/CCM SWITCHES CIRCUIT TO GROUND
O	AC1-09 PANEL / FLOOR ACTUATOR STEPPER COIL 2 DRIVE: TO ACTIVATE, A/CCM SWITCHES CIRCUIT TO GROUND
O	AC1-10 AIR TEMPERATURE BLEND ACTUATOR STEPPER COIL 1 DRIVE: TO ACTIVATE, A/CCM SWITCHES CIRCUIT TO GROUND
O	AC1-11 AIR TEMPERATURE BLEND ACTUATOR STEPPER COIL 2 DRIVE: TO ACTIVATE, A/CCM SWITCHES CIRCUIT TO GROUND
O	AC1-12 AIR TEMPERATURE BLEND ACTUATOR POWER SUPPLY: B+
O	AC1-13 DEFROST DOOR ACTUATOR POWER SUPPLY: B+
I	AC1-14 EVAPORATOR TEMPERATURE SENSOR SIGNAL, NOMINAL 0 – 5 V: NTC SENSOR – VOLTAGE DECREASES AS TEMPERATURE INCREASES
I	AC1-15 DISCHARGE TEMPERATURE SENSOR SIGNAL, NOMINAL 0 – 5 V: NTC SENSOR – VOLTAGE DECREASES AS TEMPERATURE INCREASES
SG	AC1-16 SENSOR GROUND: GROUND
O	AC1-20 DEFROST DOOR ACTUATOR STEPPER COIL 3 DRIVE: TO ACTIVATE, A/CCM SWITCHES CIRCUIT TO GROUND
O	AC1-21 DEFROST DOOR ACTUATOR STEPPER COIL 4 DRIVE: TO ACTIVATE, A/CCM SWITCHES CIRCUIT TO GROUND
O	AC1-22 PANEL / FLOOR ACTUATOR STEPPER COIL 3 DRIVE: TO ACTIVATE, A/CCM SWITCHES CIRCUIT TO GROUND
O	AC1-23 PANEL / FLOOR ACTUATOR STEPPER COIL 4 DRIVE: TO ACTIVATE, A/CCM SWITCHES CIRCUIT TO GROUND
O	AC1-24 AIR TEMPERATURE BLEND ACTUATOR STEPPER COIL 3 DRIVE: TO ACTIVATE, A/CCM SWITCHES CIRCUIT TO GROUND
O	AC1-25 AIR TEMPERATURE BLEND ACTUATOR STEPPER COIL 4 DRIVE: TO ACTIVATE, A/CCM SWITCHES CIRCUIT TO GROUND
O	AC1-26 PANEL / FLOOR ACTUATOR POWER SUPPLY: B+
B+	IP101-01 BATTERY SAVER POWER SUPPLY: B+
B+	IP101-02 IGNITION SWITCHED POWER SUPPLY: B+
O	IP101-03 WINDSHIELD HEATER RELAY DRIVE: TO ACTIVATE, A/CCM SWITCHES CIRCUIT TO GROUND
O	IP101-04 HEATED REAR WINDOW RELAY DRIVE: TO ACTIVATE, A/CCM SWITCHES CIRCUIT TO GROUND
I	IP101-07 BLOWER SPEED SENSE: B+ WHEN BLOWER OFF, 0 V WHEN BLOWER RUNNING
C	IP101-09 CAN +
C	IP101-10 CAN –
B+	IP101-14 BATTERY POWER SUPPLY: B+
PG	IP101-15 POWER GROUND: GROUND
I	IP101-20 DIMMER CONTROLLED ILLUMINATION: PWM, 80Hz, GROUND = 0% DUTY CYCLE, B+ = 100% DUTY CYCLE
C	IP101-22 CAN +
C	IP101-23 CAN –
O	IP135-1 BLOWER SPEED CONTROL 1: TO ACTIVATE, A/CCM SWITCHES CIRCUIT TO GROUND
PG	IP135-2 BLOWER GROUND: GROUND
O	IP39-1 BLOWER SPEED CONTROL 6: TO ACTIVATE, A/CCM SWITCHES CIRCUIT TO GROUND
O	IP39-2 BLOWER SPEED CONTROL 4: TO ACTIVATE, A/CCM SWITCHES CIRCUIT TO GROUND
O	IP39-3 BLOWER SPEED CONTROL 2: TO ACTIVATE, A/CCM SWITCHES CIRCUIT TO GROUND
O	IP39-4 BLOWER SPEED CONTROL 3: TO ACTIVATE, A/CCM SWITCHES CIRCUIT TO GROUND
O	IP39-6 BLOWER SPEED CONTROL 5: TO ACTIVATE, A/CCM SWITCHES CIRCUIT TO GROUND

NOTE: Refer to the Appendix at the rear of this book for Network Messages.

The following abbreviations are used to represent values for Control Module Pin-Out data

I	Input	PG	Power Ground	CAN	CAN Network	D	Serial and Encoded Data
O	Output	SS	Sensor / Signal Supply V	SCP	SCP Network	V	Voltage (DC)
B+	Battery Voltage	SG	Sensor / Signal Ground	D2	D2B Network	PWM	Pulse Width Modulated

CAUTION: The information on this data page is furnished to aid the user in understanding circuit operation. THIS INFORMATION SHOULD BE USED FOR REFERENCE ONLY.

NOTE: The characteristics listed are approximately those that can be expected at the control module connector pins with all circuit connections made and all components connected and fitted.

Fig. 06.1

COMPONENTS

Component	Connector(s)	Connector Description	Location
AIR CONDITIONING BLOWER RELAY	—	—	CENTRAL JUNCTION FUSE BOX R20
AIR CONDITIONING CONTROL MODULE (MANUAL, PANEL)	AC1 IP39 IP101 IP135	26-WAY / YELLOW 6-WAY / GREY 26-WAY / YELLOW 2-WAY / GREY	BEHIND CLIMATE CONTROL PANEL
AIR TEMPERATURE BLEND ACTUATOR	AC2	6-WAY / BLACK	RH SIDE OF AIR DISTRIBUTION UNIT
BLOWER (MANUAL)	IP58	2-WAY / GREY	BEHIND INSTRUMENT PANEL, RH SIDE / LHD, LH SIDE / RHD
BLOWER SERIES RESISTOR	IP121	6-WAY / GREY	ADJACENT TO BLOWER MOTOR
CENTRAL JUNCTION FUSE BOX	CA75 CA76 CA77 CA78	8-WAY / GREY 16-WAY / GREEN 2-WAY / GREY 16-WAY / GREY	PASSENGER COMPARTMENT, FRONT BULKHEAD LH SIDE
	IP1 IP2 IP3 IP4	14-WAY / GREEN 16-WAY / GREY 2-WAY / GREY 14-WAY / GREY	
	JB50 JB51 JB52	4-WAY / GREY 16-WAY / BLUE 2-WAY / BLACK	
DEFROST DOOR ACTUATOR	AC4	6-WAY / BLACK	RH SIDE OF AIR DISTRIBUTION UNIT
DISCHARGE TEMPERATURE SENSOR	AC6	2-WAY / BLACK	RH SIDE OF AIR DISTRIBUTION UNIT
DOOR MIRROR – LH	FL5	22-WAY / BLACK	LH FRONT DOOR
DOOR MIRROR – RH	FR4	22-WAY / BLACK	RH FRONT DOOR
EVAPORATOR TEMPERATURE SENSOR	AC5	2-WAY / BLACK	RH SIDE OF AIR DISTRIBUTION UNIT
FRESH / RECIRCULATION FLAP ACTUATOR	AC7	4-WAY / BLACK	LH SIDE OF AIR DISTRIBUTION UNIT (LHD) RH SIDE OF AIR DISTRIBUTION UNIT (RHD)
HEATED REAR WINDOW	ZA1 ZA10	— —	REAR WINDOW
HEATED REAR WINDOW RELAY	—	—	CENTRAL JUNCTION FUSE BOX R19
PANEL / FLOOR ACTUATOR	AC3	6-WAY / BLACK	RH SIDE OF AIR DISTRIBUTION UNIT
POWER DISTRIBUTION FUSE BOX	—	—	ENGINE COMPARTMENT LH SIDE
WINDSHIELD HEATER – LH	JB95	2-WAY / BLACK	WINDSHIELD
WINDSHIELD HEATER – RH	JB96	2-WAY / BLACK	WINDSHIELD
WINDSHIELD HEATER RELAY	—	—	POWER DISTRIBUTION FUSE BOX R2

HARNESS IN-LINE CONNECTORS

Connector	Connector Description	Location
CA15	20-WAY / BLACK / DOOR HARNESS TO CABIN HARNESS	DRIVER SIDE A POST
CA20	20-WAY / BLACK / DOOR HARNESS TO CABIN HARNESS	DRIVER SIDE A POST
CA127	2-WAY / GREY / CABIN HARNESS TO HEATED REAR WINDOW	BEHIND LH E POST TRIM

GROUND

Ground	Location
G3	PASSENGER COMPARTMENT / LH E POST
G4	PASSENGER COMPARTMENT / RH LOWER A POST
G14	ENGINE COMPARTMENT / REARWARD OF POWER DISTRIBUTION FUSE BOX
G15	PASSENGER COMPARTMENT / LH LOWER A POST
G36	PASSENGER COMPARTMENT / RH CROSS CAR BEAM
G37	PASSENGER COMPARTMENT / LH CROSS CAR BEAM

FOR CONTROL MODULE PIN-OUT INFORMATION, UNFOLD PAGE TO LEFT.

Refer to the front of this book for detailed information and illustrations regarding the location and identification of harnesses, relays, fuses, grounds, control modules and control module pins.

Air Conditioning Control Module: Automatic

Pin	Description and Characteristic
O AC1-04	FRESH / RECIRCULATION FLAP ACTUATOR DRIVE: TO ACTIVATE, A/CCM SWITCHES CIRCUIT TO B+ OR TO GROUND
O AC1-05	FRESH / RECIRCULATION FLAP ACTUATOR DRIVE: TO ACTIVATE, A/CCM SWITCHES CIRCUIT TO B+ OR TO GROUND
O AC1-06	DEFROST DOOR ACTUATOR STEPPER COIL 1 DRIVE: TO ACTIVATE, A/CCM SWITCHES CIRCUIT TO GROUND
O AC1-07	DEFROST DOOR ACTUATOR STEPPER COIL 2 DRIVE: TO ACTIVATE, A/CCM SWITCHES CIRCUIT TO GROUND
O AC1-08	PANEL / FLOOR ACTUATOR STEPPER COIL 1 DRIVE: TO ACTIVATE, A/CCM SWITCHES CIRCUIT TO GROUND
O AC1-09	PANEL / FLOOR ACTUATOR STEPPER COIL 2 DRIVE: TO ACTIVATE, A/CCM SWITCHES CIRCUIT TO GROUND
O AC1-10	AIR TEMPERATURE BLEND ACTUATOR STEPPER COIL 1 DRIVE: TO ACTIVATE, A/CCM SWITCHES CIRCUIT TO GROUND
O AC1-11	AIR TEMPERATURE BLEND ACTUATOR STEPPER COIL 2 DRIVE: TO ACTIVATE, A/CCM SWITCHES CIRCUIT TO GROUND
O AC1-12	AIR TEMPERATURE BLEND ACTUATOR POWER SUPPLY: B+
O AC1-13	DEFROST DOOR ACTUATOR POWER SUPPLY: B+
I AC1-14	EVAPORATOR TEMPERATURE SENSOR SIGNAL, NOMINAL 0 – 5 V: NTC SENSOR – VOLTAGE DECREASES AS TEMPERATURE INCREASES
I AC1-15	DISCHARGE TEMPERATURE SENSOR SIGNAL, NOMINAL 0 – 5 V: NTC SENSOR – VOLTAGE DECREASES AS TEMPERATURE INCREASES
I AC1-16	SENSOR GROUND: GROUND
O AC1-20	DEFROST DOOR ACTUATOR STEPPER COIL 3 DRIVE: TO ACTIVATE, A/CCM SWITCHES CIRCUIT TO GROUND
O AC1-21	DEFROST DOOR ACTUATOR STEPPER COIL 4 DRIVE: TO ACTIVATE, A/CCM SWITCHES CIRCUIT TO GROUND
O AC1-22	PANEL / FLOOR ACTUATOR STEPPER COIL 3 DRIVE: TO ACTIVATE, A/CCM SWITCHES CIRCUIT TO GROUND
O AC1-23	PANEL / FLOOR ACTUATOR STEPPER COIL 4 DRIVE: TO ACTIVATE, A/CCM SWITCHES CIRCUIT TO GROUND
O AC1-24	AIR TEMPERATURE BLEND ACTUATOR STEPPER COIL 3 DRIVE: TO ACTIVATE, A/CCM SWITCHES CIRCUIT TO GROUND
O AC1-25	AIR TEMPERATURE BLEND ACTUATOR STEPPER COIL 4 DRIVE: TO ACTIVATE, A/CCM SWITCHES CIRCUIT TO GROUND
O AC1-26	PANEL / FLOOR ACTUATOR POWER SUPPLY: B+
B+	IP101-01 BATTERY SAVER POWER SUPPLY: B+
B+	IP101-02 IGNITION SWITCHED POWER SUPPLY: B+
O	IP101-03 WINDSHIELD HEATER RELAY DRIVE: TO ACTIVATE, A/CCM SWITCHES CIRCUIT TO GROUND
O	IP101-04 HEATED REAR WINDOW RELAY DRIVE: TO ACTIVATE, A/CCM SWITCHES CIRCUIT TO GROUND
I	IP101-05 ASPIRATOR MOTOR DRIVE: PERMANENTLY CONNECTED TO GROUND; A/CCM MONITORS CIRCUIT FOR MOTOR RUNNING CONDITION
O	IP101-06 BLOWER MOTOR CONTROL: PWM, 400 Hz, APPROXIMATELY 8% – 90%; HIGHER DUTY CYCLE = HIGHER BLOWER SPEED
I	IP101-07 BLOWER MOTOR SPEED SENSE: FREQUENCY = RPM / 20; FREQUENCY PROPORTIONAL TO BLOWER SPEED
C	IP101-09 CAN +
C	IP101-10 CAN –
B+	IP101-14 BATTERY POWER SUPPLY: B+
PG	IP101-15 POWER GROUND: GROUND
I	IP101-16 IN CAR TEMPERATURE SENSOR SIGNAL, NOMINAL 0 – 5 V: NTC SENSOR – VOLTAGE DECREASES AS TEMPERATURE INCREASES
SG	IP101-17 SENSOR GROUND: GROUND
I	IP101-18 SOLAR SENSOR SIGNAL, NOMINAL 0 – 5 V: DARKER = HIGHER VOLTAGE
I	IP101-19 AMBIENT TEMPERATURE SENSOR SIGNAL, NOMINAL 0 – 5 V: NTC SENSOR – VOLTAGE DECREASES AS TEMPERATURE INCREASES
I	IP101-20 DIMMER CONTROLLED ILLUMINATION: PWM, 80Hz, GROUND = 0% DUTY CYCLE, B+ = 100% DUTY CYCLE
O	IP101-21 AIR CONDITIONING BLOWER RELAY DRIVE: TO ACTIVATE, A/CCM SWITCHES CIRCUIT TO B+
C	IP101-22 CAN +
C	IP101-23 CAN –

NOTE: Refer to the Appendix at the rear of this book for Network Messages.

COMPONENTS

Component	Connector(s)	Connector Description	Location
AIR CONDITIONING BLOWER RELAY	—	—	CENTRAL JUNCTION FUSE BOX R20
AIR CONDITIONING CONTROL MODULE (AUTOMATIC, PANEL)	AC1 IP101	26-WAY / YELLOW 26-WAY / YELLOW	BEHIND CLIMATE CONTROL PANEL
AIR CONDITIONING CONTROL MODULE (REMOTE)	AC1 IP101	26-WAY / YELLOW 26-WAY / YELLOW	RH SIDE OF AIR DISTRIBUTION UNIT
AIR TEMPERATURE BLEND ACTUATOR	AC2	6-WAY / BLACK	RH SIDE OF AIR DISTRIBUTION UNIT
AMBIENT TEMPERATURE SENSOR	JB105	2-WAY / BLACK	FRONT CROSS MEMBER, ADJACENT TO RADIATOR LH SIDE
BLOWER (AUTOMATIC)	IP134	6-WAY / BLACK	BEHIND INSTRUMENT PANEL RH SIDE
CENTRAL JUNCTION FUSE BOX	CA75 CA76 CA77 CA78 IP1 IP2 IP3 IP4 JB50 JB51 JB52	8-WAY / GREY 16-WAY / GREEN 2-WAY / GREY 16-WAY / GREY 14-WAY / GREEN 16-WAY / GREY 2-WAY / GREY 14-WAY / GREY 4-WAY / GREY 16-WAY / BLUE 2-WAY / BLACK	PASSENGER COMPARTMENT, FRONT BULKHEAD LH SIDE
DEFROST DOOR ACTUATOR	AC4	6-WAY / BLACK	RH SIDE OF AIR DISTRIBUTION UNIT
DISCHARGE TEMPERATURE SENSOR	AC6	2-WAY / BLACK	RH SIDE OF AIR DISTRIBUTION UNIT
DOOR MIRROR – LH	FL5	22-WAY / BLACK	LH FRONT DOOR
DOOR MIRROR – RH	FR4	22-WAY / BLACK	RH FRONT DOOR
EVAPORATOR TEMPERATURE SENSOR	AC5	2-WAY / BLACK	RH SIDE OF AIR DISTRIBUTION UNIT
FRESH / RECIRCULATION FLAP ACTUATOR	AC7	4-WAY / BLACK	LH SIDE OF AIR DISTRIBUTION UNIT (LHD) RH SIDE OF AIR DISTRIBUTION UNIT (RHD)
HEATED REAR WINDOW	ZA1 ZA10	— —	REAR WINDOW
HEATED REAR WINDOW RELAY	—	—	CENTRAL JUNCTION FUSE BOX R19
IN-CAR TEMPERATURE SENSOR	IP66	4-WAY / BLACK	BELOW INSTRUMENT PANEL CENTER RIGHT
PANEL / FLOOR ACTUATOR	AC3	6-WAY / BLACK	RH SIDE OF AIR DISTRIBUTION UNIT
POWER DISTRIBUTION FUSE BOX	—	—	ENGINE COMPARTMENT LH SIDE
SOLAR SENSOR	IP38	2-WAY / BLACK	TOP CENTER OF INSTRUMENT PANEL
WINDSHIELD HEATER – LH	JB95	2-WAY / BLACK	WINDSHIELD
WINDSHIELD HEATER – RH	JB96	2-WAY / BLACK	WINDSHIELD
WINDSHIELD HEATER RELAY	—	—	POWER DISTRIBUTION FUSE BOX R2

HARNES IN-LINE CONNECTORS

Connector	Connector Description	Location
CA15	20-WAY / BLACK / DOOR HARNESS TO CABIN HARNESS	DRIVER SIDE A POST
CA20	20-WAY / BLACK / DOOR HARNESS TO CABIN HARNESS	DRIVER SIDE A POST
CA127	2-WAY / GREY / CABIN HARNESS TO HEATED REAR WINDOW	BEHIND LH E POST TRIM
JB3	14-WAY / BLUE / JUNCTION BOX HARNESS TO INSTRUMENT PANEL HARNESS	BELOW INSTRUMENT PANEL LH SIDE
JB130	22-WAY / GREEN / JUNCTION BOX HARNESS TO INSTRUMENT PANEL HARNESS	ADJACENT TO CENTRAL JUNCTION FUSE BOX

GROUND

Ground	Location
G3	PASSENGER COMPARTMENT / LH E POST
G4	PASSENGER COMPARTMENT / RH LOWER A POST
G14	ENGINE COMPARTMENT / REARWARD OF POWER DISTRIBUTION FUSE BOX
G15	PASSENGER COMPARTMENT / LH LOWER A POST
G36	PASSENGER COMPARTMENT / RH CROSS CAR BEAM
G37	PASSENGER COMPARTMENT / LH CROSS CAR BEAM

FOR CONTROL MODULE PIN-OUT INFORMATION, UNFOLD PAGE TO LEFT.

The following abbreviations are used to represent values for Control Module Pin-Out data

I	Input	PG	Power Ground	CAN	CAN Network	D	Serial and Encoded Data
O	Output	SS	Sensor / Signal Supply V	SCP	SCP Network	V	Voltage (DC)
B+	Battery Voltage	SG	Sensor / Signal Ground	D2	D2B Network	PWM	Pulse Width Modulated

CAUTION: The information on this data page is furnished to aid the user in understanding circuit operation. THIS INFORMATION SHOULD BE USED FOR REFERENCE ONLY.

NOTE: The characteristics listed are approximately those that can be expected at the control module connector pins with all circuit connections made and all components connected and fitted.

Refer to the front of this book for detailed information and illustrations regarding the location and identification of harnesses, relays, fuses, grounds, control modules and control module pins.

CONTROL MODULE PIN-OUT INFORMATION

General Electronic Control Module

Pin	Description and Characteristic
S IP5-18	SCP -
S IP5-19	SCP +
I IP6-18	SEAT BELT AND AIRBAG AUDIBLE WARNING REQUEST: AUDIBLE WARNING REQUEST ACTIVE = GROUND

Instrument Cluster

Pin	Description and Characteristic
I IP10-7	FUEL LEVEL SENSOR 1 SIGNAL: VARIABLE RESISTANCE: 20 Ω = EMPTY; 160 Ω = FULL
I IP10-8	FUEL LEVEL SENSOR 2 SIGNAL: VARIABLE RESISTANCE: 20 Ω = EMPTY; 160 Ω = FULL
SG IP10-9	FUEL LEVEL SENSOR REFERENCE: GROUND
I IP10-10	MAIN BEAM STATUS: B+ WHEN ACTIVATED
I IP10-11	WASHER FLUID LEVEL LOW SIGNAL: FLUID LEVEL LOW = GROUND
I IP10-12	BRAKE FLUID LEVEL WARNING SIGNAL: FLUID LEVEL LOW = GROUND
I IP10-15	PARKING BRAKE SIGNAL: PARKING BRAKE ON = GROUND
I IP10-16	TRIP COMPUTER CYCLE SWITCH: GROUND WHEN ACTIVATED
C IP10-17	CAN +
C IP10-18	CAN -
I IP10-19	FRONT FOG STATUS (HARD WIRED TO INDICATOR): B+ WHEN ACTIVATED
I IP10-20	REAR FOG STATUS (HARD WIRED TO INDICATOR): B+ WHEN ACTIVATED
S IP10-22	SCP +
S IP10-23	SCP -
I IP10-24	TRIP COMPUTER MODE SIGNAL: STEPPED RESISTANCE
SG IP10-25	TRIP COMPUTER SWITCH PACK REFERENCE: GROUND
I IP11-5	ENGINE OIL PRESSURE SIGNAL: ENGINE OIL PRESSURE PRESENT = GROUND
I IP11-7	BATTERY POWER SUPPLY: B+
I IP11-8	POWER GROUND: GROUND
I IP11-11	IGNITION SWITCHED POWER SUPPLY (II): B+
I IP11-13	IGNITION SWITCHED POWER SUPPLY (I): B+
I IP11-15	SIDE LAMPS STATUS: B+ WHEN ACTIVATED
I IP11-17	DIP BEAM STATUS: B+ WHEN ACTIVATED
I IP11-19	AIR BAG WARNING: HARD WIRED TO AIR BAG INDICATOR
I IP11-21	DIMMER CONTROLLED ILLUMINATION: PWM, 80 Hz, GROUND = 0% DUTY CYCLE, B+ = 100% DUTY CYCLE; HARD WIRED TO BACK LIGHTING; MICRO SENSED FOR DISPLAY

NOTE: Refer to the Appendix at the rear of this book for Network Messages.

Fig. 07.1

COMPONENTS

Component	Connector(s)	Connector Description	Location
BRAKE FLUID SWITCH	JB70	3-WAY / BLACK	BRAKE MASTER CYLINDER
FUEL LEVEL SENSOR 1 (2.5L & 3.0L)	FT2	4-WAY / BLACK	FUEL TANK
FUEL LEVEL SENSOR 2 (2.5L & 3.0L)	FT3	4-WAY / BLACK	FUEL TANK
FUEL LEVEL SENSOR (2.0L)	CA415	4-WAY / BLACK	FUEL TANK
GENERAL ELECTRONIC CONTROL MODULE	CA86	23-WAY / GREY	BEHIND INSTRUMENT PANEL RH SIDE
	CA87	23-WAY / GREEN	
	IP5	23-WAY / BROWN	
	IP6	23-WAY / WHITE	
	JB172	23-WAY / BLUE	
INSTRUMENT CLUSTER	IP10	26-WAY / YELLOW	INSTRUMENT PANEL
	IP11	26-WAY / YELLOW	
MASTER LIGHTING SWITCH	IP17	16-WAY / BLACK	INSTRUMENT PANEL
OIL PRESSURE SWITCH	EN19	1-WAY / BLACK	ADJACENT TO ENGINE OIL FILTER
RESTRAINTS CONTROL MODULE	CA165	40-WAY / BLACK	UNDER CENTER CONSOLE
	IP74	24-WAY / BLACK	
TURN SIGNAL SWITCH	IP53	10-WAY / GREY	STEERING COLUMN
WASHER FLUID LEVEL SWITCH	JB103	2-WAY / BLACK	ENGINE COMPARTMENT RH FRONT

HARNESS IN-LINE CONNECTORS

Connector	Connector Description	Location
CA1	22-WAY / NATURAL / CABIN HARNESS TO INSTRUMENT PANEL HARNESS	LH LOWER A POST
CA5	12-WAY / BLACK / CABIN HARNESS TO FUEL TANK LINK LEAD	TOP OF FUEL TANK
CA169	4-WAY / GREY / CABIN HARNESS TO INSTRUMENT PANEL HARNESS	BELOW THE GLOVEBOX
JB1	42-WAY / BLACK / JUNCTION BOX HARNESS TO ENGINE HARNESS	ADJACENT TO LH SUSPENSION TURRET
JB129	22-WAY / GREY / INSTRUMENT PANEL HARNESS TO JUNCTION BOX HARNESS	LH LOWER A POST

GROUND

Ground	Location
G10	ENGINE COMPARTMENT / UNDER RH HEADLAMP ASSEMBLY
G14	ENGINE COMPARTMENT / REARWARD OF POWER DISTRIBUTION FUSE BOX
G36	PASSENGER COMPARTMENT / RH CROSS CAR BEAM
G37	PASSENGER COMPARTMENT / LH CROSS CAR BEAM

FOR CONTROL MODULE PIN-OUT INFORMATION, UNFOLD PAGE TO LEFT.

The following abbreviations are used to represent values for Control Module Pin-Out data

I	Input	PG	Power Ground	CAN	CAN Network	D	Serial and Encoded Data
O	Output	SS	Sensor / Signal Supply V	SCP	SCP Network	V	Voltage (DC)
B+	Battery Voltage	SG	Sensor / Signal Ground	D2	D2B Network	PWM	Pulse Width Modulated

CAUTION: The information on this data page is furnished to aid the user in understanding circuit operation. THIS INFORMATION SHOULD BE USED FOR REFERENCE ONLY.

NOTE: The characteristics listed are approximately those that can be expected at the control module connector pins with all circuit connections made and all components connected and fitted.

Refer to the front of this book for detailed information and illustrations regarding the location and identification of harnesses, relays, fuses, grounds, control modules and control module pins.

CONTROL MODULE PIN-OUT INFORMATION

Fig. 07.2

General Electronic Control Module

Pin	Description and Characteristic
PG	CA86-5 POWER GROUND: GROUND
S	IP5-18 SCP -
S	IP5-19 SCP +
SG	IP6-1 LOGIC GROUND: GROUND
I	IP6-8 KEY-IN IGNITION SWITCH: B+ WHEN KEY IN
I	IP6-15 NOT-IN-PARK SWITCH: PARK = OPEN CIRCUIT; NOT-IN-PARK = GROUND
I	IP6-18 SEAT BELT AND AIRBAG AUDIBLE WARNING REQUEST: AUDIBLE WARNING REQUEST ACTIVE = GROUND
I	IP6-22 DRIVER DOOR AJAR: DOOR OPEN = OPEN CIRCUIT; DOOR CLOSED = GROUND
B+	JB172-5 BATTERY POWER SUPPLY (TURN SIGNALS): B+

NOTE: Refer to the Appendix at the rear of this book for Network Messages.

COMPONENTS

Component	Connector(s)	Connector Description	Location
DOOR LATCH ASSEMBLY - LH FRONT	FL3 FL9	8-WAY / BLACK 2-WAY / BLACK	LH FRONT DOOR
DOOR LATCH ASSEMBLY - RH FRONT	FR3 FR9	8-WAY / BLACK 2-WAY / BLACK	RH FRONT DOOR
GENERAL ELECTRONIC CONTROL MODULE	CA86 CA87 IP5 IP6 JB172	23-WAY / GREY 23-WAY / GREEN 23-WAY / BROWN 23-WAY / WHITE 23-WAY / BLUE	BEHIND INSTRUMENT PANEL RH SIDE
IGNITION SWITCH	IP18	7-WAY / BLACK	STEERING COLUMN
INSTRUMENT CLUSTER	IP10 IP11	26-WAY / YELLOW 26-WAY / YELLOW	INSTRUMENT PANEL
J GATE ASSEMBLY	IP14	16-WAY / GREEN	CENTER CONSOLE
RESTRAINTS CONTROL MODULE	CA165 IP74	40-WAY / BLACK 24-WAY / BLACK	UNDER CENTER CONSOLE

HARNESS IN-LINE CONNECTORS

Connector	Connector Description	Location
CA1	22-WAY / NATURAL / CABIN HARNESS TO INSTRUMENT PANEL HARNESS	LH LOWER A POST
CA15	20-WAY / BLACK / DOOR HARNESS TO CABIN HARNESS	DRIVER SIDE A POST
CA20	20-WAY / BLACK / DOOR HARNESS TO CABIN HARNESS	DRIVER SIDE A POST

GROUNDINGS

Ground	Location
G4	PASSENGER COMPARTMENT / RH LOWER A POST
G5	PASSENGER COMPARTMENT / RH LOWER A POST
G15	PASSENGER COMPARTMENT / LH LOWER A POST
G37	PASSENGER COMPARTMENT / LH CROSS CAR BEAM

FOR CONTROL MODULE PIN-OUT INFORMATION, UNFOLD PAGE TO LEFT.

The following abbreviations are used to represent values for Control Module Pin-Out data

I	Input	PG	Power Ground	CAN	CAN Network	D	Serial and Encoded Data
O	Output	SS	Sensor / Signal Supply V	SCP	SCP Network	V	Voltage (DC)
B+	Battery Voltage	SG	Sensor / Signal Ground	D2	D2B Network	PWM	Pulse Width Modulated

CAUTION: The information on this data page is furnished to aid the user in understanding circuit operation. THIS INFORMATION SHOULD BE USED FOR REFERENCE ONLY.

NOTE: The characteristics listed are approximately those that can be expected at the control module connector pins with all circuit connections made and all components connected and fitted.

Refer to the front of this book for detailed information and illustrations regarding the location and identification of harnesses, relays, fuses, grounds, control modules and control module pins.

General Electronic Control Module

Pin	Description and Characteristic
PG	CA86-5 POWER GROUND: GROUND
I	IP5-3 EXTERNAL ANTENNA
S	IP5-18 SCP -
S	IP5-19 SCP +
O	IP5-22 TURN SIGNAL AUDIBLE WARNING: TO ACTIVATE, GECM SWITCHES CIRCUIT TO B+
SG	IP6-1 LOGIC GROUND: GROUND
I	IP6-11 MAIN BEAM SWITCH: GROUND WHEN SELECTED
O	IP6-13 MAIN BEAM / FRONT FOG RELAY DRIVE: TO ACTIVATE, GECM SWITCHES CIRCUIT TO B+
I	IP6-17 LH TURN SIGNAL SWITCH: GROUND WHEN SELECTED
I	IP6-19 RH TURN SIGNAL SWITCH: GROUND WHEN SELECTED
I	IP6-23 HAZARD SWITCH: GROUND WHEN SELECTED
O	JB172-3 RH FRONT TURN SIGNAL: TO ACTIVATE, GECM SWITCHES CIRCUIT TO B+
O	JB172-4 LH FRONT TURN SIGNAL: TO ACTIVATE, GECM SWITCHES CIRCUIT TO B+
B+	JB172-5 BATTERY POWER SUPPLY (TURN SIGNALS): B+

NOTE: Refer to the Appendix at the rear of this book for Network Messages.

COMPONENTS

Component	Connector(s)	Connector Description	Location
AUTOLAMPS SENSOR	RC5	5-WAY / BLACK	BEHIND REAR VIEW MIRROR
CENTRAL JUNCTION FUSE BOX	CA75 CA76 CA77 CA78 IP1 IP2 IP3 IP4 JB50 JB51 JB52	8-WAY / GREY 16-WAY / GREEN 2-WAY / GREY 16-WAY / GREY 14-WAY / GREEN 16-WAY / GREY 2-WAY / GREY 14-WAY / GREY 4-WAY / GREY 16-WAY / BLUE 2-WAY / BLACK	PASSENGER COMPARTMENT, FRONT BULKHEAD LH SIDE
DIP BEAM RELAY	—	—	POWER DISTRIBUTION FUSE BOX R9
FOG LAMP - LH FRONT	FB1	2-WAY / BLACK	UNDER FRONT BUMPER
FOG LAMP - RH FRONT	FB3	2-WAY / BLACK	UNDER FRONT BUMPER
GENERAL ELECTRONIC CONTROL MODULE	CA86 CA87 IP5 IP6 JB172	23-WAY / GREY 23-WAY / GREEN 23-WAY / BROWN 23-WAY / WHITE 23-WAY / BLUE	BEHIND INSTRUMENT PANEL RH SIDE
GLOVE BOX LAMP	IP25	2-WAY / BROWN	GLOVE BOX
HEADLAMP UNIT - LH	JB84	10-WAY / BLACK	LH FRONT OF VEHICLE
HEADLAMP UNIT - RH	JB85	10-WAY / BLACK	RH FRONT OF VEHICLE
MAIN BEAM / FRONT FOG RELAY	—	—	CENTRAL JUNCTION FUSE BOX R15
MASTER LIGHTING SWITCH	IP17	16-WAY / BLACK	INSTRUMENT PANEL
POWER DISTRIBUTION FUSE BOX	—	—	ENGINE COMPARTMENT LH SIDE
SIDE MARKER LAMP - LH FRONT	FB2	2-WAY / BLACK	FRONT BUMPER LH SIDE
SIDE MARKER LAMP - RH FRONT	FB4	2-WAY / BLACK	FRONT BUMPER RH SIDE
TURN REPEATER - LH	JB132	2-WAY / BLACK	LH FRONT FENDER
TURN REPEATER - RH	JB98	2-WAY / BLACK	RH FRONT FENDER
TURN SIGNAL SWITCH	IP53	10-WAY / GREY	STEERING COLUMN

HARNESS IN-LINE CONNECTORS

Connector	Connector Description	Location
CA1	22-WAY / NATURAL / CABIN HARNESS TO INSTRUMENT PANEL HARNESS	LH LOWER A POST
CA36	16-WAY / GREEN / CABIN HARNESS TO ROOF HARNESS	LH LOWER A POST
JB129	22-WAY / GREY / INSTRUMENT PANEL HARNESS TO JUNCTION BOX HARNESS	LH LOWER A POST
JB171	8-WAY / BLACK / FRONT END HARNESS TO BUMPER LINK LEAD	BEHIND FRONT LH WHEEL ARCH LINER

GROUND

Ground	Location
G4	PASSENGER COMPARTMENT / RH LOWER A POST
G5	PASSENGER COMPARTMENT / RH LOWER A POST
G10	ENGINE COMPARTMENT / UNDER RH HEADLAMP ASSEMBLY
G11	ENGINE COMPARTMENT / UNDER LH HEADLAMP ASSEMBLY
G14	ENGINE COMPARTMENT / REARWARD OF POWER DISTRIBUTION FUSE BOX
G32	ENGINE COMPARTMENT / UNDER LH HEADLAMP ASSEMBLY
G33	ENGINE COMPARTMENT / BEHIND RH HEADLAMP ASSEMBLY
G36	PASSENGER COMPARTMENT / RH CROSS CAR BEAM
G37	PASSENGER COMPARTMENT / LH CROSS CAR BEAM

FOR CONTROL MODULE PIN-OUT INFORMATION, UNFOLD PAGE TO LEFT.

The following abbreviations are used to represent values for Control Module Pin-Out data

I	Input	PG	Power Ground	CAN	CAN Network	D	Serial and Encoded Data
O	Output	SS	Sensor / Signal Supply V	SCP	SCP Network	V	Voltage (DC)
B+	Battery Voltage	SG	Sensor / Signal Ground	D2	D2B Network	PWM	Pulse Width Modulated

CAUTION: The information on this data page is furnished to aid the user in understanding circuit operation. THIS INFORMATION SHOULD BE USED FOR REFERENCE ONLY.

NOTE: The characteristics listed are approximately those that can be expected at the control module connector pins with all circuit connections made and all components connected and fitted.

Refer to the front of this book for detailed information and illustrations regarding the location and identification of harnesses, relays, fuses, grounds, control modules and control module pins.

General Electronic Control Module

P	Pin	Description and Characteristic
PG	CA86-5	POWER GROUND: GROUND
I	IP5-3	EXTERNAL ANTENNA
S	IP5-18	SCP -
S	IP5-19	SCP +
O	IP5-22	TURN SIGNAL AUDIBLE WARNING: TO ACTIVATE, GECM SWITCHES CIRCUIT TO B+
SG	IP6-1	LOGIC GROUND: GROUND
I	IP6-11	MAIN BEAM SWITCH: GROUND WHEN SELECTED
O	IP6-13	MAIN BEAM / FRONT FOG RELAY DRIVE: TO ACTIVATE, GECM SWITCHES CIRCUIT TO B+
I	IP6-17	LH TURN SIGNAL SWITCH: GROUND WHEN SELECTED
I	IP6-19	RH TURN SIGNAL SWITCH: GROUND WHEN SELECTED
I	IP6-23	HAZARD SWITCH: GROUND WHEN SELECTED
O	JB172-3	RH FRONT TURN SIGNAL: TO ACTIVATE, GECM SWITCHES CIRCUIT TO B+
O	JB172-4	LH FRONT TURN SIGNAL: TO ACTIVATE, GECM SWITCHES CIRCUIT TO B+
B+	JB172-5	BATTERY POWER SUPPLY (TURN SIGNALS): B+

COMPONENTS

Component	Connector(s)	Connector Description	Location
CENTRAL JUNCTION FUSE BOX	CA75 CA76 CA77 CA78 IP1 IP2 IP3 IP4 JB50 JB51 JB52	8-WAY / GREY 16-WAY / GREEN 2-WAY / GREY 16-WAY / GREY 14-WAY / GREEN 16-WAY / GREY 2-WAY / GREY 14-WAY / GREY 4-WAY / GREY 16-WAY / BLUE 2-WAY / BLACK	PASSENGER COMPARTMENT, FRONT BULKHEAD LH SIDE
DIP BEAM RELAY	—	—	POWER DISTRIBUTION FUSE BOX R9
FOG LAMP - LH FRONT	FB1	2-WAY / BLACK	UNDER FRONT BUMPER
FOG LAMP - RH FRONT	FB3	2-WAY / BLACK	UNDER FRONT BUMPER
GENERAL ELECTRONIC CONTROL MODULE	CA86 CA87 IP5 IP6 JB172	23-WAY / GREY 23-WAY / GREEN 23-WAY / BROWN 23-WAY / WHITE 23-WAY / BLUE	BEHIND INSTRUMENT PANEL RH SIDE
GLOVE BOX LAMP	IP25	2-WAY / BROWN	GLOVE BOX
HAZARD SWITCH	IP51	6-WAY / BLACK	CENTER CONSOLE
HEADLAMP UNIT - LH	JB84	10-WAY / BLACK	LH FRONT OF VEHICLE
HEADLAMP UNIT - RH	JB85	10-WAY / BLACK	RH FRONT OF VEHICLE
MAIN BEAM / FRONT FOG RELAY	—	—	CENTRAL JUNCTION FUSE BOX R15
MASTER LIGHTING SWITCH	IP17	16-WAY / BLACK	INSTRUMENT PANEL
POWER DISTRIBUTION FUSE BOX	—	—	ENGINE COMPARTMENT LH SIDE
SIDE MARKER LAMP - LH FRONT	FB2	2-WAY / BLACK	FRONT BUMPER LH SIDE
SIDE MARKER LAMP - RH FRONT	FB4	2-WAY / BLACK	FRONT BUMPER RH SIDE
TURN REPEATER - LH	JB132	2-WAY / BLACK	LH FRONT FENDER
TURN REPEATER - RH	JB98	2-WAY / BLACK	RH FRONT FENDER
TURN SIGNAL SWITCH	IP53	10-WAY / GREY	STEERING COLUMN

HARNES IN-LINE CONNECTORS

Connector	Connector Description	Location
JB129	22-WAY / GREY / INSTRUMENT PANEL HARNESS TO JUNCTION BOX HARNESS	LH LOWER A POST
JB171	8-WAY / BLACK / FRONT END HARNESS TO BUMPER LINK LEAD	BEHIND FRONT LH WHEEL ARCH LINER

GROUNDS

Ground	Location
G4	PASSENGER COMPARTMENT / RH LOWER A POST
G5	PASSENGER COMPARTMENT / RH LOWER A POST
G10	ENGINE COMPARTMENT / UNDER RH HEADLAMP ASSEMBLY
G11	ENGINE COMPARTMENT / UNDER LH HEADLAMP ASSEMBLY
G14	ENGINE COMPARTMENT / REARWARD OF POWER DISTRIBUTION FUSE BOX
G32	ENGINE COMPARTMENT / UNDER LH HEADLAMP ASSEMBLY
G33	ENGINE COMPARTMENT / BEHIND RH HEADLAMP ASSEMBLY
G36	PASSENGER COMPARTMENT / RH CROSS CAR BEAM
G37	PASSENGER COMPARTMENT / LH CROSS CAR BEAM

FOR CONTROL MODULE PIN-OUT INFORMATION, UNFOLD PAGE TO LEFT.

The following abbreviations are used to represent values for Control Module Pin-Out data

I	Input	PG	Power Ground	CAN	CAN Network	D	Serial and Encoded Data
O	Output	SS	Sensor / Signal Supply V	SCP	SCP Network	V	Voltage (DC)
B+	Battery Voltage	SG	Sensor / Signal Ground	D2	D2B Network	PWM	Pulse Width Modulated

CAUTION: The information on this data page is furnished to aid the user in understanding circuit operation. THIS INFORMATION SHOULD BE USED FOR REFERENCE ONLY.

NOTE: The characteristics listed are approximately those that can be expected at the control module connector pins with all circuit connections made and all components connected and fitted.

Refer to the front of this book for detailed information and illustrations regarding the location and identification of harnesses, relays, fuses, grounds, control modules and control module pins.

CONTROL MODULE PIN-OUT INFORMATION

Fig. 08.3

General Electronic Control Module

Pin	Description and Characteristic
O CA86-2	LH REAR TURN SIGNAL: TO ACTIVATE, GECM SWITCHES CIRCUIT TO B+
PG CA86-5	POWER GROUND: GROUND
O CA87-4	RH REAR TURN SIGNAL: TO ACTIVATE, GECM SWITCHES CIRCUIT TO B+
S IP5-18	SCP -
S IP5-19	SCP +
O IP5-22	TURN SIGNAL AUDIBLE WARNING: TO ACTIVATE, GECM SWITCHES CIRCUIT TO B+
SG IP6-1	LOGIC GROUND: GROUND
I IP6-17	LH TURN SIGNAL SWITCH: GROUND WHEN SELECTED
I IP6-19	RH TURN SIGNAL SWITCH: GROUND WHEN SELECTED
I IP6-23	HAZARD SWITCH: GROUND WHEN SELECTED
B+	JB172-5 BATTERY POWER SUPPLY (TURN SIGNALS): B+

Instrument Cluster

Pin	Description and Characteristic
I IP10-1	REVERSE LAMP SWITCH: B+ WHEN ACTIVATED
C IP10-17	CAN +
C IP10-18	CAN -
O IP11-3	REVERSE LAMPS RELAY DRIVE: TO ACTIVATE, IC SWITCHES CIRCUIT TO GROUND

NOTE: Refer to the Appendix at the rear of this book for Network Messages.

COMPONENTS

Component	Connector(s)	Connector Description	Location	
BRAKE ON / OFF SWITCH	PA3	3-WAY / BLACK	TOP OF BRAKE PEDAL	
CENTRAL JUNCTION FUSE BOX	CA75	8-WAY / GREY	PASSENGER COMPARTMENT, FRONT BULKHEAD LH SIDE	
	CA76	16-WAY / GREEN		
	CA77	2-WAY / GREY		
	CA78	16-WAY / GREY		
	IP1	14-WAY / GREEN		
	IP2	16-WAY / GREY		
	IP3	2-WAY / GREY		
	IP4	14-WAY / GREY		
	JB50	4-WAY / GREY		
	JB51	16-WAY / BLUE		
GENERAL ELECTRONIC CONTROL MODULE	JB52	2-WAY / BLACK	BEHIND INSTRUMENT PANEL RH SIDE	
	CA86	23-WAY / GREY		
	CA87	23-WAY / GREEN		
	IP5	23-WAY / BROWN		
	IP6	23-WAY / WHITE		
	JB172	23-WAY / BLUE		
HAZARD SWITCH	IP51	6-WAY / BLACK		CENTER CONSOLE
HIGH MOUNT STOP LAMP	CA304	2-WAY / BLACK		REAR WINDOW
INSTRUMENT CLUSTER	IP10	26-WAY / YELLOW		INSTRUMENT PANEL
	IP11	26-WAY / YELLOW		
LICENSE PLATE LAMP - LH	TM4	2-WAY / BLACK	TRUNK LID	
LICENSE PLATE LAMP - RH	TM5	2-WAY / BLACK	TRUNK LID	
MASTER LIGHTING SWITCH	IP17	16-WAY / BLACK	INSTRUMENT PANEL	
REVERSE LAMPS RELAY	—	—	CENTRAL JUNCTION FUSE BOX R17	
REVERSE LAMPS SWITCH	EN85	2-WAY / BLACK	TOP OF TRANSMISSION	
SIDE MARKER LAMP - LH REAR	RB5	2-WAY / BLACK	REAR BUMPER LH SIDE	
SIDE MARKER LAMP - RH REAR	RB6	2-WAY / BLACK	REAR BUMPER RH SIDE	
TAIL LAMP UNIT - LH	CA137	7-WAY / BLACK	TRUNK LH REAR	
TAIL LAMP UNIT - RH	CA138	7-WAY / BLACK	TRUNK RH REAR	
TURN SIGNAL SWITCH	IP53	10-WAY / GREY	STEERING COLUMN	

HARNESS IN-LINE CONNECTORS

Connector	Connector Description	Location
CA1	22-WAY / NATURAL / CABIN HARNESS TO INSTRUMENT PANEL HARNESS	LH LOWER A POST
CA10	22-WAY / GREY / ENGINE HARNESS TO CABIN HARNESS	BELOW THE GLOVEBOX
CA45	6-WAY / GREY / CABIN HARNESS TO TRUNK LID HARNESS	TRUNK LH REAR
CA129	12-WAY / GREY / CABIN HARNESS TO REAR BUMPER HARNESS	SPARE WHEEL WELL
CA170	16-WAY / GREEN / IN-LINE CONNECTOR	LH LOWER A POST
JB2	16-WAY / GREEN / JUNCTION BOX HARNESS TO CABIN HARNESS	ADJACENT TO CENTRAL JUNCTION FUSE BOX
JB145	8-WAY / BLACK / ENGINE HARNESS TO JUNCTION BOX HARNESS	ADJACENT TO CENTRAL JUNCTION FUSE BOX
JB196	10-WAY / GREY / JUNCTION BOX HARNESS TO CABIN HARNESS	ADJACENT TO FOOT PEDALS
TL10	6-WAY / GREY / TRUNK LID HARNESS	BELOW PARCEL SHELF LH SIDE

GROUND

Ground	Location
G1	TRUNK / LH REAR
G2	TRUNK / LH REAR
G4	PASSENGER COMPARTMENT / RH LOWER A POST
G5	PASSENGER COMPARTMENT / RH LOWER A POST
G36	PASSENGER COMPARTMENT / RH CROSS CAR BEAM
G37	PASSENGER COMPARTMENT / LH CROSS CAR BEAM
G38	PASSENGER COMPARTMENT / TOP OF LH E POST

FOR CONTROL MODULE PIN-OUT INFORMATION, UNFOLD PAGE TO LEFT.

The following abbreviations are used to represent values for Control Module Pin-Out data

I	Input	PG	Power Ground	CAN	CAN Network	D	Serial and Encoded Data
O	Output	SS	Sensor / Signal Supply V	SCP	SCP Network	V	Voltage (DC)
B+	Battery Voltage	SG	Sensor / Signal Ground	D2	D2B Network	PWM	Pulse Width Modulated

CAUTION: The information on this data page is furnished to aid the user in understanding circuit operation. THIS INFORMATION SHOULD BE USED FOR REFERENCE ONLY.

NOTE: The characteristics listed are approximately those that can be expected at the control module connector pins with all circuit connections made and all components connected and fitted.

Refer to the front of this book for detailed information and illustrations regarding the location and identification of harnesses, relays, fuses, grounds, control modules and control module pins.

CONTROL MODULE PIN-OUT INFORMATION

Fig. 08.4

General Electronic Control Module

Pin	Description and Characteristic
O	CA86-2 LH REAR TURN SIGNAL: TO ACTIVATE, GECM SWITCHES CIRCUIT TO B+
PG	CA86-5 POWER GROUND: GROUND
O	CA87-4 RH REAR TURN SIGNAL: TO ACTIVATE, GECM SWITCHES CIRCUIT TO B+
S	IP5-18 SCP -
S	IP5-19 SCP +
O	IP5-22 TURN SIGNAL AUDIBLE WARNING: TO ACTIVATE, GECM SWITCHES CIRCUIT TO B+
SG	IP6-1 LOGIC GROUND: GROUND
I	IP6-17 LH TURN SIGNAL SWITCH: GROUND WHEN SELECTED
I	IP6-19 RH TURN SIGNAL SWITCH: GROUND WHEN SELECTED
I	IP6-23 HAZARD SWITCH: GROUND WHEN SELECTED
B+	JB172-5 BATTERY POWER SUPPLY (TURN SIGNALS): B+

NOTE: Refer to the Appendix at the rear of this book for Network Messages.

COMPONENTS

Component	Connector(s)	Connector Description	Location
BRAKE ON / OFF SWITCH	PA3	3-WAY / BLACK	TOP OF BRAKE PEDAL
CENTRAL JUNCTION FUSE BOX	CA75 CA76 CA77 CA78 IP1 IP2 IP3 IP4	8-WAY / GREY 16-WAY / GREEN 2-WAY / GREY 16-WAY / GREY 14-WAY / GREEN 16-WAY / GREY 2-WAY / GREY 14-WAY / GREY	PASSENGER COMPARTMENT, FRONT BULKHEAD LH SIDE
GENERAL ELECTRONIC CONTROL MODULE	JB50 JB51 JB52 CA86 CA87 IP5 IP6 JB172	4-WAY / GREY 16-WAY / BLUE 2-WAY / BLACK 23-WAY / GREY 23-WAY / GREEN 23-WAY / BROWN 23-WAY / WHITE 23-WAY / BLUE	BEHIND INSTRUMENT PANEL RH SIDE
HAZARD SWITCH	IP51	6-WAY / BLACK	CENTER CONSOLE
HIGH MOUNT STOP LAMP	CA304	2-WAY / BLACK	REAR WINDOW
LICENSE PLATE LAMP - LH	TM4	2-WAY / BLACK	TRUNK LID
LICENSE PLATE LAMP - RH	TM5	2-WAY / BLACK	TRUNK LID
MASTER LIGHTING SWITCH	IP17	16-WAY / BLACK	INSTRUMENT PANEL
TAIL LAMP UNIT - LH	TT4	7-WAY / BLACK	TRUNK LH REAR
TAIL LAMP UNIT - RH	TT5	7-WAY / BLACK	TRUNK RH REAR
TRAILER CONNECTOR	T5011 T312N T6US1	- - -	TRUNK RH REAR
TRAILER TOWING CONTROL MODULE	TT1 TT2 TT3	- - -	SPARE WHEEL WELL
TRAILER TOWING REAR ACCESSORY CONNECTOR	T3001 T4001 T5001	- - -	TRUNK RH REAR
TURN SIGNAL SWITCH	IP53	10-WAY / GREY	STEERING COLUMN

HARNES IN-LINE CONNECTORS

Connector	Connector Description	Location
CA45	6-WAY / GREY / CABIN HARNESS TO TRUNK LID HARNESS	TRUNK LH REAR
CA129	12-WAY / GREY / CABIN HARNESS TO REAR BUMPER HARNESS	SPARE WHEEL WELL
CA146	3-WAY / BLACK / ACCESSORY SOCKET	ADJACENT TO LH REAR TAIL LAMP
CA170	16-WAY / GREEN / IN-LINE CONNECTOR	LH LOWER A POST
CA175	TRAILER TOWING CONNECTOR	TRUNK
CA176	TRAILER TOWING CONNECTOR	TRUNK
CA302	2-WAY / GREY / CABIN HARNESS TO TRAILER HARNESS	ADJACENT TO LH REAR TAIL LAMP
JB2	16-WAY / GREEN / JUNCTION BOX HARNESS TO CABIN HARNESS	ADJACENT TO CENTRAL JUNCTION FUSE BOX
JB196	10-WAY / GREY / JUNCTION BOX HARNESS TO CABIN HARNESS	ADJACENT TO FOOT PEDALS
TL10	6-WAY / GREY / TRUNK LID HARNESS	BELOW PARCEL SHELF LH SIDE
TT6	TRAILER TOWING CONNECTOR	TRUNK

GROUND S

Ground	Location
G1	TRUNK / LH REAR
G2	TRUNK / LH REAR
G4	PASSENGER COMPARTMENT / RH LOWER A POST
G5	PASSENGER COMPARTMENT / RH LOWER A POST
G36	PASSENGER COMPARTMENT / RH CROSS CAR BEAM
G37	PASSENGER COMPARTMENT / LH CROSS CAR BEAM
G38	PASSENGER COMPARTMENT / TOP OF LH E POST

FOR CONTROL MODULE PIN-OUT INFORMATION, UNFOLD PAGE TO LEFT.

The following abbreviations are used to represent values for Control Module Pin-Out data

I	Input	PG	Power Ground	CAN	CAN Network	D	Serial and Encoded Data
O	Output	SS	Sensor / Signal Supply V	SCP	SCP Network	V	Voltage (DC)
B+	Battery Voltage	SG	Sensor / Signal Ground	D2	D2B Network	PWM	Pulse Width Modulated

CAUTION: The information on this data page is furnished to aid the user in understanding circuit operation. THIS INFORMATION SHOULD BE USED FOR REFERENCE ONLY.

NOTE: The characteristics listed are approximately those that can be expected at the control module connector pins with all circuit connections made and all components connected and fitted.

Refer to the front of this book for detailed information and illustrations regarding the location and identification of harnesses, relays, fuses, grounds, control modules and control module pins.

CONTROL MODULE PIN-OUT INFORMATION

Fig. 08.5

General Electronic Control Module

Pin	Description and Characteristic
O CA86-2	LH REAR TURN SIGNAL: TO ACTIVATE, GECM SWITCHES CIRCUIT TO B+
PG CA86-5	POWER GROUND: GROUND
O CA87-4	RH REAR TURN SIGNAL: TO ACTIVATE, GECM SWITCHES CIRCUIT TO B+
S IP5-18	SCP -
S IP5-19	SCP +
O IP5-22	TURN SIGNAL AUDIBLE WARNING: TO ACTIVATE, GECM SWITCHES CIRCUIT TO B+
SG IP6-1	LOGIC GROUND: GROUND
I IP6-17	LH TURN SIGNAL SWITCH: GROUND WHEN SELECTED
I IP6-19	RH TURN SIGNAL SWITCH: GROUND WHEN SELECTED
I IP6-23	HAZARD SWITCH: GROUND WHEN SELECTED
B+ JB172-5	BATTERY POWER SUPPLY (TURN SIGNALS): B+

NOTE: Refer to the Appendix at the rear of this book for Network Messages.

COMPONENTS

Component	Connector(s)	Connector Description	Location
BRAKE ON / OFF SWITCH	PA3	3-WAY / BLACK	TOP OF BRAKE PEDAL
CARAVAN CONNECTOR	T412S	—	TRUNK RH REAR
CENTRAL JUNCTION FUSE BOX	CA75 CA76 CA77 CA78 IP1 IP2 IP3 IP4 JB50 JB51 JB52	8-WAY / GREY 16-WAY / GREEN 2-WAY / GREY 16-WAY / GREY 14-WAY / GREEN 16-WAY / GREY 2-WAY / GREY 14-WAY / GREY 4-WAY / GREY 16-WAY / BLUE 2-WAY / BLACK	PASSENGER COMPARTMENT, FRONT BULKHEAD LH SIDE
GENERAL ELECTRONIC CONTROL MODULE	CA86 CA87 IP5 IP6 JB172	23-WAY / GREY 23-WAY / GREEN 23-WAY / BROWN 23-WAY / WHITE 23-WAY / BLUE	BEHIND INSTRUMENT PANEL RH SIDE
HAZARD SWITCH	IP51	6-WAY / BLACK	CENTER CONSOLE
HIGH MOUNT STOP LAMP	CA304	2-WAY / BLACK	REAR WINDOW
LICENSE PLATE LAMP - LH	TM4	2-WAY / BLACK	TRUNK LID
LICENSE PLATE LAMP - RH	TM5	2-WAY / BLACK	TRUNK LID
MASTER LIGHTING SWITCH	IP17	16-WAY / BLACK	INSTRUMENT PANEL
TAIL LAMP UNIT - LH	TT4	7-WAY / BLACK	TRUNK LH REAR
TAIL LAMP UNIT - RH	TT5	7-WAY / BLACK	TRUNK RH REAR
TRAILER CONNECTOR	T5011 T312N T6US1	— — —	TRUNK RH REAR
TRAILER TOWING CONTROL MODULE	TT1 TT2 TT3	— — —	SPARE WHEEL WELL
TRAILER TOWING REAR ACCESSORY CONNECTOR	T3001 T4001 T5001	— — —	TRUNK RH REAR
TURN SIGNAL SWITCH	IP53	10-WAY / GREY	STEERING COLUMN

HARNESS IN-LINE CONNECTORS

Connector	Connector Description	Location
CA1	22-WAY / NATURAL / CABIN HARNESS TO INSTRUMENT PANEL HARNESS	LH LOWER A POST
CA45	6-WAY / GREY / CABIN HARNESS TO TRUNK LID HARNESS	TRUNK LH REAR
CA129	12-WAY / GREY / CABIN HARNESS TO REAR BUMPER HARNESS	SPARE WHEEL WELL
CA146	3-WAY / BLACK / ACCESSORY SOCKET	ADJACENT TO LH REAR TAIL LAMP
CA170	16-WAY / GREEN / IN-LINE CONNECTOR	LH LOWER A POST
CA175	TRAILER TOWING CONNECTOR	TRUNK
CA176	TRAILER TOWING CONNECTOR	TRUNK
CA302	2-WAY / GREY / CABIN HARNESS TO TRAILER HARNESS	ADJACENT TO LH REAR TAIL LAMP
JB2	16-WAY / GREEN / JUNCTION BOX HARNESS TO CABIN HARNESS	ADJACENT TO CENTRAL JUNCTION FUSE BOX
JB196	10-WAY / GREY / JUNCTION BOX HARNESS TO CABIN HARNESS	ADJACENT TO FOOT PEDALS
T3001	TRAILER TOWING CONNECTOR	TRUNK
TL10	6-WAY / GREY / TRUNK LID HARNESS	BELOW PARCEL SHELF LH SIDE
TT6	TRAILER TOWING CONNECTOR	TRUNK
TT7	TRAILER TOWING CONNECTOR	TRUNK

GROUNDINGS

Ground	Location
G1	TRUNK / LH REAR
G2	TRUNK / LH REAR
G4	PASSENGER COMPARTMENT / RH LOWER A POST
G5	PASSENGER COMPARTMENT / RH LOWER A POST
G36	PASSENGER COMPARTMENT / RH CROSS CAR BEAM
G37	PASSENGER COMPARTMENT / LH CROSS CAR BEAM
G38	PASSENGER COMPARTMENT / TOP OF LH E POST

FOR CONTROL MODULE PIN-OUT INFORMATION, UNFOLD PAGE TO LEFT.

The following abbreviations are used to represent values for Control Module Pin-Out data

I	Input	PG	Power Ground	CAN	CAN Network	D	Serial and Encoded Data
O	Output	SS	Sensor / Signal Supply V	SCP	SCP Network	V	Voltage (DC)
B+	Battery Voltage	SG	Sensor / Signal Ground	D2	D2B Network	PWM	Pulse Width Modulated

CAUTION: The information on this data page is furnished to aid the user in understanding circuit operation. THIS INFORMATION SHOULD BE USED FOR REFERENCE ONLY.

NOTE: The characteristics listed are approximately those that can be expected at the control module connector pins with all circuit connections made and all components connected and fitted.

Refer to the front of this book for detailed information and illustrations regarding the location and identification of harnesses, relays, fuses, grounds, control modules and control module pins.

CONTROL MODULE PIN-OUT INFORMATION

Fig. 08.6

General Electronic Control Module

Pin	Description and Characteristic
O CA86-2	LH REAR TURN SIGNAL: TO ACTIVATE, GECM SWITCHES CIRCUIT TO B+
PG CA86-5	POWER GROUND: GROUND
O CA87-4	RH REAR TURN SIGNAL: TO ACTIVATE, GECM SWITCHES CIRCUIT TO B+
S IP5-18	SCP -
S IP5-19	SCP +
O IP5-22	TURN SIGNAL AUDIBLE WARNING: TO ACTIVATE, GECM SWITCHES CIRCUIT TO B+
SG IP6-1	LOGIC GROUND: GROUND
I IP6-17	LH TURN SIGNAL SWITCH: GROUND WHEN SELECTED
I IP6-19	RH TURN SIGNAL SWITCH: GROUND WHEN SELECTED
I IP6-23	HAZARD SWITCH: GROUND WHEN SELECTED
B+ JB172-5	BATTERY POWER SUPPLY (TURN SIGNALS): B+

NOTE: Refer to the Appendix at the rear of this book for Network Messages.

COMPONENTS

Component	Connector(s)	Connector Description	Location
BRAKE ON / OFF SWITCH	PA3	3-WAY / BLACK	TOP OF BRAKE PEDAL
CENTRAL JUNCTION FUSE BOX	CA75 CA76 CA77 CA78 IP1 IP2 IP3 IP4 JB50 JB51 JB52	8-WAY / GREY 16-WAY / GREEN 2-WAY / GREY 16-WAY / GREY 14-WAY / GREEN 16-WAY / GREY 2-WAY / GREY 14-WAY / GREY 4-WAY / GREY 16-WAY / BLUE 2-WAY / BLACK	PASSENGER COMPARTMENT, FRONT BULKHEAD LH SIDE
GENERAL ELECTRONIC CONTROL MODULE	CA86 CA87 IP5 IP6 JB172	23-WAY / GREY 23-WAY / GREEN 23-WAY / BROWN 23-WAY / WHITE 23-WAY / BLUE	BEHIND INSTRUMENT PANEL RH SIDE
HAZARD SWITCH	IP51	6-WAY / BLACK	CENTER CONSOLE
HIGH MOUNT STOP LAMP	CA304	2-WAY / BLACK	REAR WINDOW
LICENSE PLATE LAMP - LH	TM4	2-WAY / BLACK	TRUNK LID
LICENSE PLATE LAMP - RH	TM5	2-WAY / BLACK	TRUNK LID
MASTER LIGHTING SWITCH	IP17	16-WAY / BLACK	INSTRUMENT PANEL
SIDE MARKER LAMP - LH REAR	RB5	2-WAY / BLACK	REAR BUMPER LH SIDE
SIDE MARKER LAMP - RH REAR	RB6	2-WAY / BLACK	REAR BUMPER RH SIDE
TAIL LAMP UNIT - LH	TT4	7-WAY / BLACK	TRUNK LH REAR
TAIL LAMP UNIT - RH	TT5	7-WAY / BLACK	TRUNK RH REAR
TRAILER CONNECTOR	T5011 T312N T6US1	- - -	TRUNK RH REAR
TRAILER TOWING CONTROL MODULE	TT1 TT2 TT3	- - -	SPARE WHEEL WELL
TRAILER TOWING REAR ACCESSORY CONNECTOR	T3001 T4001 T5001	- - -	TRUNK RH REAR
TURN SIGNAL SWITCH	IP53	10-WAY / GREY	STEERING COLUMN

HARNES IN-LINE CONNECTORS

Connector	Connector Description	Location
CA1	22-WAY / NATURAL / CABIN HARNESS TO INSTRUMENT PANEL HARNESS	LH LOWER A POST
CA45	6-WAY / GREY / CABIN HARNESS TO TRUNK LID HARNESS	TRUNK LH REAR
CA129	12-WAY / GREY / CABIN HARNESS TO REAR BUMPER HARNESS	SPARE WHEEL WELL
CA146	3-WAY / BLACK / ACCESSORY SOCKET	ADJACENT TO LH REAR TAIL LAMP
CA170	16-WAY / GREEN / IN-LINE CONNECTOR	LH LOWER A POST
CA175	TRAILER TOWING CONNECTOR	TRUNK
CA176	TRAILER TOWING CONNECTOR	TRUNK
CA302	2-WAY / GREY / CABIN HARNESS TO TRAILER HARNESS	ADJACENT TO LH REAR TAIL LAMP
JB2	16-WAY / GREEN / JUNCTION BOX HARNESS TO CABIN HARNESS	ADJACENT TO CENTRAL JUNCTION FUSE BOX
TL10	6-WAY / GREY / TRUNK LID HARNESS	BELOW PARCEL SHELF LH SIDE
TT6	TRAILER TOWING CONNECTOR	TRUNK

GROUNDS

Ground	Location
G1	TRUNK / LH REAR
G2	TRUNK / LH REAR
G4	PASSENGER COMPARTMENT / RH LOWER A POST
G5	PASSENGER COMPARTMENT / RH LOWER A POST
G36	PASSENGER COMPARTMENT / RH CROSS CAR BEAM
G37	PASSENGER COMPARTMENT / LH CROSS CAR BEAM
G38	PASSENGER COMPARTMENT / TOP OF LH E POST

FOR CONTROL MODULE PIN-OUT INFORMATION, UNFOLD PAGE TO LEFT.

The following abbreviations are used to represent values for Control Module Pin-Out data

I	Input	PG	Power Ground	CAN	CAN Network	D	Serial and Encoded Data
O	Output	SS	Sensor / Signal Supply V	SCP	SCP Network	V	Voltage (DC)
B+	Battery Voltage	SG	Sensor / Signal Ground	D2	D2B Network	PWM	Pulse Width Modulated

CAUTION: The information on this data page is furnished to aid the user in understanding circuit operation. THIS INFORMATION SHOULD BE USED FOR REFERENCE ONLY.

NOTE: The characteristics listed are approximately those that can be expected at the control module connector pins with all circuit connections made and all components connected and fitted.

Refer to the front of this book for detailed information and illustrations regarding the location and identification of harnesses, relays, fuses, grounds, control modules and control module pins.

Fig. 08.7**COMPONENTS**

Component	Connector(s)	Connector Description	Location
DIP BEAM RELAY	—	—	POWER DISTRIBUTION FUSE BOX R9
FRONT AXLE SENSOR	JB140	6-WAY / BLACK	LH FRONT SUSPENSION
HEADLAMP LEVELING CONTROL MODULE	IP130	26-WAY / YELLOW	BEHIND INSTRUMENT PANEL LH SIDE
HEADLAMP UNIT – LH	JB84	10-WAY / BLACK	LH FRONT OF VEHICLE
HEADLAMP UNIT – RH	JB85	10-WAY / BLACK	RH FRONT OF VEHICLE
MASTER LIGHTING SWITCH	IP17	16-WAY / BLACK	INSTRUMENT PANEL
POWER DISTRIBUTION FUSE BOX	—	—	ENGINE COMPARTMENT LH SIDE
REAR AXLE SENSOR	HI1	6-WAY / BLACK	LH REAR SUSPENSION

HARNESS IN-LINE CONNECTORS

Connector	Connector Description	Location
CA1	22-WAY / NATURAL / CABIN HARNESS TO INSTRUMENT PANEL HARNESS	LH LOWER A POST
CA10	22-WAY / GREY / ENGINE HARNESS TO CABIN HARNESS	BELOW THE GLOVEBOX
CA241	22-WAY / GREEN / INSTRUMENT PANEL HARNESS TO CABIN HARNESS	ADJACENT TO CENTRAL JUNCTION FUSE BOX
CA302	2-WAY / GREY / CABIN HARNESS TO TRAILER HARNESS	ADJACENT TO LH REAR TAIL LAMP
JB129	22-WAY / GREY / INSTRUMENT PANEL HARNESS TO JUNCTION BOX HARNESS	LH LOWER A POST
JB130	22-WAY / GREEN / JUNCTION BOX HARNESS TO INSTRUMENT PANEL HARNESS	ADJACENT TO CENTRAL JUNCTION FUSE BOX

GROUNDS

Ground	Location
G10	ENGINE COMPARTMENT / UNDER RH HEADLAMP ASSEMBLY
G11	ENGINE COMPARTMENT / UNDER LH HEADLAMP ASSEMBLY
G36	PASSENGER COMPARTMENT / RH CROSS CAR BEAM
G37	PASSENGER COMPARTMENT / LH CROSS CAR BEAM

Refer to the front of this book for detailed information and illustrations regarding the location and identification of harnesses, relays, fuses, grounds, control modules and control module pins.

General Electronic Control Module

Pin	Description and Characteristic
O CA86-1	LH AND RH DOOR COURTESY LAMPS : TO ACTIVATE, GECM SWITCHES CIRCUIT TO GROUND
O CA86-3	INTERIOR LAMPS : TO ACTIVATE, GECM SWITCHES CIRCUIT TO GROUND
PG CA86-5	POWER GROUND: GROUND
I CA86-14	RESET SWITCH: OPEN CIRCUIT / GROUND
I CA86-16	SET SWITCH: OPEN CIRCUIT / GROUND
I CA86-18	RH REAR DOOR AJAR: DOOR OPEN = OPEN CIRCUIT; DOOR CLOSED = GROUND
I CA87-15	LH REAR DOOR AJAR: DOOR OPEN = OPEN CIRCUIT; DOOR CLOSED = GROUND
I IP5-3	EXTERNAL ANTENNA
S IP5-18	SCP -
S IP5-19	SCP +
SG IP6-1	LOGIC GROUND: GROUND
I IP6-21	PASSENGER DOOR AJAR: DOOR OPEN = OPEN CIRCUIT; DOOR CLOSED = GROUND
I IP6-22	DRIVER DOOR AJAR: DOOR OPEN = OPEN CIRCUIT; DOOR CLOSED = GROUND
B+ JB172-1	BATTERY POWER SUPPLY (LOCKING): B+

NOTE: Refer to the Appendix at the rear of this book for Network Messages.

COMPONENTS

Component	Connector(s)	Connector Description	Location
DOOR COURTESY LAMP – LH	FL7	2-WAY / WHITE	LH FRONT DOOR
DOOR COURTESY LAMP – RH	FR6	2-WAY / WHITE	RH FRONT DOOR
DOOR LATCH ASSEMBLY – LH FRONT	FL3 FL9	8-WAY / BLACK 2-WAY / BLACK	LH FRONT DOOR
DOOR LATCH ASSEMBLY – LH REAR	BL3 BL6	8-WAY / BLACK 2-WAY / BLACK	LH REAR DOOR
DOOR LATCH ASSEMBLY – RH FRONT	FR3 FR9	8-WAY / BLACK 2-WAY / BLACK	RH FRONT DOOR
DOOR LATCH ASSEMBLY – RH REAR	BR3 BR6	8-WAY / BLACK 2-WAY / BLACK	RH REAR DOOR
FOOTWELL LAMP – LH	IP27	2-WAY / WHITE	INSTRUMENT PANEL LH SIDE
FOOTWELL LAMP – RH	IP26	2-WAY / WHITE	INSTRUMENT PANEL RH SIDE
GENERAL ELECTRONIC CONTROL MODULE	CA86 CA87 IP5 IP6 JB172	23-WAY / GREY 23-WAY / GREEN 23-WAY / BROWN 23-WAY / WHITE 23-WAY / BLUE	BEHIND INSTRUMENT PANEL RH SIDE
GLOVE BOX LAMP	IP25	2-WAY / BROWN	GLOVE BOX
REAR INTERIOR LAMP	RC11 RC20	2-WAY / BLACK 1-WAY / RED	REAR HEAD LINER
ROOF CONSOLE	RC22 RC30 RC31 RC33 RC34	22-WAY / BLACK 4-WAY / BLACK 2-WAY / BLACK 4-WAY / BLACK 6-WAY / BLACK	ROOF, CENTER FRONT
TRUNK LAMP	CA132	2-WAY / BLACK	TRUNK RH SIDE
TRUNK LOCK MOTOR	TM6	5-WAY / NATURAL	TRUNK LID
VANITY MIRROR LAMP – LH	RC9	2-WAY / BLACK	LH SUN VISOR
VANITY MIRROR LAMP – RH	RC8	2-WAY / BLACK	RH SUN VISOR

HARNESS IN-LINE CONNECTORS

Connector	Connector Description	Location
CA1	22-WAY / NATURAL / CABIN HARNESS TO INSTRUMENT PANEL HARNESS	LH LOWER A POST
CA15	20-WAY / BLACK / DOOR HARNESS TO CABIN HARNESS	DRIVER SIDE A POST
CA16	20-WAY / BLACK / DOOR HARNESS TO CABIN HARNESS	DRIVER SIDE A POST
CA20	20-WAY / BLACK / DOOR HARNESS TO CABIN HARNESS	DRIVER SIDE A POST
CA21	20-WAY / BLACK / DOOR HARNESS TO CABIN HARNESS	DRIVER SIDE A POST
CA25	14-WAY / NATURAL / REAR DOOR HARNESS TO CABIN HARNESS	LH B/C POST
CA30	14-WAY / NATURAL / DOOR LOCK LINK LEAD	RH B/C POST
CA36	16-WAY / GREEN / CABIN HARNESS TO ROOF HARNESS	LH LOWER A POST
CA45	6-WAY / GREY / CABIN HARNESS TO TRUNK LID HARNESS	TRUNK LH REAR
TL10	6-WAY / GREY / TRUNK LID HARNESS	BELOW PARCEL SHELF LH SIDE

GROUND

Ground	Location
G1	TRUNK / LH REAR
G4	PASSENGER COMPARTMENT / RH LOWER A POST
G5	PASSENGER COMPARTMENT / RH LOWER A POST
G15	PASSENGER COMPARTMENT / LH LOWER A POST
G37	PASSENGER COMPARTMENT / LH CROSS CAR BEAM

FOR CONTROL MODULE PIN-OUT INFORMATION, UNFOLD PAGE TO LEFT.

The following abbreviations are used to represent values for Control Module Pin-Out data

I Input	PG Power Ground	CAN CAN Network	D Serial and Encoded Data
O Output	SS Sensor / Signal Supply V	SCP SCP Network	V Voltage (DC)
B+ Battery Voltage	SG Sensor / Signal Ground	D2 D2B Network	PWM Pulse Width Modulated

CAUTION: The information on this data page is furnished to aid the user in understanding circuit operation. THIS INFORMATION SHOULD BE USED FOR REFERENCE ONLY.

NOTE: The characteristics listed are approximately those that can be expected at the control module connector pins with all circuit connections made and all components connected and fitted.

Refer to the front of this book for detailed information and illustrations regarding the location and identification of harnesses, relays, fuses, grounds, control modules and control module pins.

Fig. 09.2

COMPONENTS

Component	Connector(s)	Connector Description	Location
AIR CONDITIONING CONTROL MODULE (AUTOMATIC, PANEL)	AC1 IP101	26-WAY / YELLOW 26-WAY / YELLOW	BEHIND CLIMATE CONTROL PANEL
AIR CONDITIONING CONTROL MODULE (MANUAL, PANEL)	AC1 IP39 IP101 IP135	26-WAY / YELLOW 6-WAY / GREY 26-WAY / YELLOW 2-WAY / GREY	BEHIND CLIMATE CONTROL PANEL
AUDIO UNIT	ID1 IP65 IP106	2-WAY / BLACK 20-WAY / BLACK 2-WAY / COAXIAL	INSTRUMENT PANEL CENTER
CIGAR LIGHTER	IP42	2-WAY / ORANGE	ASH TRAY
DOOR SWITCH PACK – DRIVER	FL1 FR1	20-WAY / BLACK 20-WAY / BLACK	DRIVER DOOR ARM REST
DOOR SWITCH PACK – LH REAR	BL1	8-WAY / BLACK	LH REAR DOOR
DOOR SWITCH PACK – PASSENGER	FL10	8-WAY / BLACK	PASSENGER DOOR
DOOR SWITCH PACK – RH REAR	BR1	8-WAY / BLACK	RH REAR DOOR
DYNAMIC STABILITY CONTROL SWITCH	IP29	6-WAY / BLACK	INSTRUMENT PANEL
HAZARD, SEAT HEATER SWITCHES	IP51	6-WAY / BLACK	CENTER CONSOLE
INSTRUMENT CLUSTER	IP10 IP11	26-WAY / YELLOW 26-WAY / YELLOW	INSTRUMENT PANEL
J GATE ASSEMBLY	IP14	16-WAY / GREEN	CENTER CONSOLE
MASTER LIGHTING SWITCH	IP17	16-WAY / BLACK	INSTRUMENT PANEL
ROOF CONSOLE	RC22 RC30 RC31 RC33 RC34	22-WAY / BLACK 4-WAY / BLACK 2-WAY / BLACK 4-WAY / BLACK 6-WAY / BLACK	ROOF, CENTER FRONT
STEERING WHEEL	SW4	6-WAY / BLACK	STEERING COLUMN
TELEMATICS DISPLAY	IP70 IP136 IP137 IP138 IP139	22-WAY / BLACK 2-WAY 2-WAY 2-WAY 2-WAY	CENTER CONSOLE

HARNESS IN-LINE CONNECTORS

Connector	Connector Description	Location
CA1	22-WAY / NATURAL / CABIN HARNESS TO INSTRUMENT PANEL HARNESS	LH LOWER A POST
CA15	20-WAY / BLACK / DOOR HARNESS TO CABIN HARNESS	DRIVER SIDE A POST
CA20	20-WAY / BLACK / DOOR HARNESS TO CABIN HARNESS	DRIVER SIDE A POST
CA25	14-WAY / NATURAL / REAR DOOR HARNESS TO CABIN HARNESS	LH B/C POST
CA30	14-WAY / NATURAL / DOOR LOCK LINK LEAD	RH B/C POST
CA36	16-WAY / GREEN / CABIN HARNESS TO ROOF HARNESS	LH LOWER A POST
JB1	42-WAY / BLACK / JUNCTION BOX HARNESS TO ENGINE HARNESS	ADJACENT TO LH SUSPENSION TURRET
JB129	22-WAY / GREY / INSTRUMENT PANEL HARNESS TO JUNCTION BOX HARNESS	LH LOWER A POST

GROUNDS

Ground	Location
G4	PASSENGER COMPARTMENT / RH LOWER A POST
G5	PASSENGER COMPARTMENT / RH LOWER A POST
G14	ENGINE COMPARTMENT / REARWARD OF POWER DISTRIBUTION FUSE BOX
G15	PASSENGER COMPARTMENT / LH LOWER A POST
G36	PASSENGER COMPARTMENT / RH CROSS CAR BEAM
G37	PASSENGER COMPARTMENT / LH CROSS CAR BEAM

Refer to the front of this book for detailed information and illustrations regarding the location and identification of harnesses, relays, fuses, grounds, control modules and control module pins.

CONTROL MODULE PIN-OUT INFORMATION

Instrument Cluster

Pin	Description and Characteristic
C IP10-17	CAN +
C IP10-18	CAN -
I IP11-8	POWER GROUND: GROUND
I IP11-23	VARIABLE ASSIST POWER STEERING FEEDBACK: CLOSED LOOP
I IP11-24	IGNITION SWITCHED POWER SUPPLY: B+
O IP11-25	VARIABLE ASSIST POWER STEERING DRIVE: 864 mA = MAXIMUM ASSIST; 0 mA = MINIMUM ASSIST

NOTE: Refer to the Appendix at the rear of this book for Network Messages.

Fig. 10.1

COMPONENTS

Component	Connector(s)	Connector Description	Location
ELECTROCHROMIC REAR VIEW MIRROR	RC5	5-WAY / BLACK	REAR VIEW MIRROR
INSTRUMENT CLUSTER	IP10 IP11	26-WAY / YELLOW 26-WAY / YELLOW	INSTRUMENT PANEL
VARIABLE ASSIST SERVO	EM91	2-WAY	STEERING RACK PINION HOUSING

HARNESS IN-LINE CONNECTORS

Connector	Connector Description	Location
CA36	16-WAY / GREEN / CABIN HARNESS TO ROOF HARNESS	LH LOWER A POST
JB130	22-WAY / GREEN / JUNCTION BOX HARNESS TO INSTRUMENT PANEL HARNESS	ADJACENT TO CENTRAL JUNCTION FUSE BOX
JB145	8-WAY / BLACK / ENGINE HARNESS TO JUNCTION BOX HARNESS	ADJACENT TO CENTRAL JUNCTION FUSE BOX

GROUNDINGS

Ground	Location
G15	PASSENGER COMPARTMENT / LH LOWER A POST
G36	PASSENGER COMPARTMENT / RH CROSS CAR BEAM
G37	PASSENGER COMPARTMENT / LH CROSS CAR BEAM

FOR CONTROL MODULE PIN-OUT INFORMATION, UNFOLD PAGE TO LEFT.

The following abbreviations are used to represent values for Control Module Pin-Out data

I	Input	PG	Power Ground	CAN	CAN Network	D	Serial and Encoded Data
O	Output	SS	Sensor / Signal Supply V	SCP	SCP Network	V	Voltage (DC)
B+	Battery Voltage	SG	Sensor / Signal Ground	D2	D2B Network	PWM	Pulse Width Modulated

CAUTION: The information on this data page is furnished to aid the user in understanding circuit operation. THIS INFORMATION SHOULD BE USED FOR REFERENCE ONLY.

NOTE: The characteristics listed are approximately those that can be expected at the control module connector pins with all circuit connections made and all components connected and fitted.

Refer to the front of this book for detailed information and illustrations regarding the location and identification of harnesses, relays, fuses, grounds, control modules and control module pins.

Fig. 10.2**COMPONENTS**

Component	Connector(s)	Connector Description	Location
DOOR SWITCH PACK – DRIVER	FL1 FR1	20-WAY / BLACK 20-WAY / BLACK	DRIVER DOOR ARM REST
FOLD FLAT MODULE	CA270	7-WAY / GREY	BEHIND PASSENGER AIR BAG
DOOR MIRROR – LH	FL5	22-WAY / BLACK	LH FRONT DOOR
DOOR MIRROR – RH	FR4	22-WAY / BLACK	RH FRONT DOOR

HARNESS IN-LINE CONNECTORS

Connector	Connector Description	Location
CA15	20-WAY / BLACK / DOOR HARNESS TO CABIN HARNESS	DRIVER SIDE A POST
CA16	20-WAY / BLACK / DOOR HARNESS TO CABIN HARNESS	DRIVER SIDE A POST
CA20	20-WAY / BLACK / DOOR HARNESS TO CABIN HARNESS	DRIVER SIDE A POST
CA21	20-WAY / BLACK / DOOR HARNESS TO CABIN HARNESS	DRIVER SIDE A POST
CA65	18-WAY / BLACK / CABIN HARNESS TO SEAT HARNESS	BELOW RH FRONT SEAT
CA70	18-WAY / BLACK / CABIN HARNESS TO SEAT HARNESS	BELOW LH FRONT SEAT

GROUNDS

Ground	Location
G4	PASSENGER COMPARTMENT / RH LOWER A POST
G15	PASSENGER COMPARTMENT / LH LOWER A POST

Refer to the front of this book for detailed information and illustrations regarding the location and identification of harnesses, relays, fuses, grounds, control modules and control module pins.

Fig. 11.1**COMPONENTS**

Component	Connector(s)	Connector Description	Location
SEAT LUMBAR PUMP – LH	LS19	3-WAY / WHITE	LH SEAT
SEAT LUMBAR PUMP – RH	RS19	3-WAY / WHITE	RH SEAT
SEAT LUMBAR SWITCH PACK – LH	LS16	7-WAY / BLACK	LH FRONT SEAT
SEAT LUMBAR SWITCH PACK – RH	RS16	7-WAY / BLACK	RH FRONT SEAT
SEAT MOVEMENT MOTORS – LH	LS2 LS4 LS5 LS6	2-WAY / BLACK 2-WAY / RED 2-WAY / BLACK 2-WAY / RED	BELOW LH SEAT
SEAT MOVEMENT MOTORS – RH	RS2 RS4 RS5 RS6	2-WAY / BLACK 2-WAY / RED 2-WAY / BLACK 2-WAY / BLACK	BELOW RH SEAT
SEAT SWITCH PACK – LH	LS1	12-WAY / GREY	LH SEAT
SEAT SWITCH PACK – RH	RS1	12-WAY / GREY	RH SEAT

HARNES IN-LINE CONNECTORS

Connector	Connector Description	Location
CA65	18-WAY / BLACK / CABIN HARNESS TO SEAT HARNESS	BELOW RH FRONT SEAT
CA70	18-WAY / BLACK / CABIN HARNESS TO SEAT HARNESS	BELOW LH FRONT SEAT

GROUND

Ground	Location
G4	PASSENGER COMPARTMENT / RH LOWER A POST
G15	PASSENGER COMPARTMENT / LH LOWER A POST

Refer to the front of this book for detailed information and illustrations regarding the location and identification of harnesses, relays, fuses, grounds, control modules and control module pins.

Fig. 11.2**COMPONENTS**

Component	Connector(s)	Connector Description	Location
SEAT MOVEMENT MOTOR – LH	LS10	2-WAY / RED	BELOW LH SEAT
SEAT MOVEMENT MOTOR – RH	RS10	2-WAY / RED	BELOW RH SEAT
SEAT SWITCH PACK – LH	LS1	12-WAY / GREY	LH SEAT
SEAT SWITCH PACK – RH	RS1	12-WAY / GREY	RH SEAT

HARNESS IN-LINE CONNECTORS

Connector	Connector Description	Location
CA65	18-WAY / BLACK / CABIN HARNESS TO SEAT HARNESS	BELOW RH FRONT SEAT
CA70	18-WAY / BLACK / CABIN HARNESS TO SEAT HARNESS	BELOW LH FRONT SEAT

GROUNDS

Ground	Location
G4	PASSENGER COMPARTMENT / RH LOWER A POST
G15	PASSENGER COMPARTMENT / LH LOWER A POST

Refer to the front of this book for detailed information and illustrations regarding the location and identification of harnesses, relays, fuses, grounds, control modules and control module pins.

Fig. 11.3**COMPONENTS**

Component	Connector(s)	Connector Description	Location
SEAT BACK HEATER – LH	LS7	4-WAY / GREY	BELOW LH SEAT
SEAT BACK HEATER – RH	RS7	4-WAY / GREY	BELOW RH SEAT
SEAT CUSHION HEATER – LH	LS7	4-WAY / GREY	BELOW LH SEAT
SEAT CUSHION HEATER – RH	RS7	4-WAY / GREY	BELOW RH SEAT
SEAT HEATER MODULE – LH	LS13	12-WAY / GREY	BELOW LH SEAT
SEAT HEATER MODULE – RH	RS13	12-WAY / GREY	BELOW RH SEAT
SEAT HEATER SWITCH – LH	IP51	6-WAY / BLACK	CENTER CONSOLE
SEAT HEATER SWITCH – RH	IP56	6-WAY / BLACK	CENTER CONSOLE

HARNESS IN-LINE CONNECTORS

Connector	Connector Description	Location
CA65	18-WAY / BLACK / CABIN HARNESS TO SEAT HARNESS	BELOW RH FRONT SEAT
CA70	18-WAY / BLACK / CABIN HARNESS TO SEAT HARNESS	BELOW LH FRONT SEAT
CA240	12-WAY / GREY / CABIN HARNESS TO INSTRUMENT PANEL HARNESS	LH LOWER A POST

GROUNDS

Ground	Location
G4	PASSENGER COMPARTMENT / RH LOWER A POST
G5	PASSENGER COMPARTMENT / RH LOWER A POST
G15	PASSENGER COMPARTMENT / LH LOWER A POST
G36	PASSENGER COMPARTMENT / RH CROSS CAR BEAM

Refer to the front of this book for detailed information and illustrations regarding the location and identification of harnesses, relays, fuses, grounds, control modules and control module pins.

CONTROL MODULE PIN-OUT INFORMATION

Fig. 12.1

General Electronic Control Module

Pin	Description and Characteristic
O CA86-4	CENTRAL LOCKING MOTORS DRIVE – DOUBLE LOCKING: TO ACTIVATE, GECM SWITCHES CIRCUIT TO B+
PG CA86-5	POWER GROUND: GROUND
I CA86-14	RESET SWITCH: OPEN CIRCUIT / GROUND
I CA86-16	SET SWITCH: OPEN CIRCUIT / GROUND
I CA86-18	RH REAR DOOR AJAR: DOOR OPEN = OPEN CIRCUIT; DOOR CLOSED = GROUND
I CA86-19	LOCK SWITCH: OPEN CIRCUIT / GROUND
I CA86-22	TRUNK LID AJAR: TRUNK OPEN = OPEN CIRCUIT; TRUNK CLOSED = GROUND
O CA87-2	TRUNK LOCK MOTOR DRIVE: TO ACTIVATE, GECM SWITCHES CIRCUIT TO B+
O CA87-3	CENTRAL LOCKING MOTORS DRIVE – LOCK: TO ACTIVATE, GECM SWITCHES CIRCUIT TO B+
O CA87-5	CENTRAL LOCKING REAR MOTORS DRIVE – UNLOCK: TO ACTIVATE, GECM SWITCHES CIRCUIT TO B+
I CA87-15	LH REAR DOOR AJAR: DOOR OPEN = OPEN CIRCUIT; DOOR CLOSED = GROUND
I CA87-16	UNLOCK SWITCH: OPEN CIRCUIT / GROUND
O IP5-1	PASSENGER DOORS LOCK MOTOR DRIVE – UNLOCK: TO ACTIVATE, GECM SWITCHES CIRCUIT TO B+
I IP5-3	EXTERNAL ANTENNA
O IP5-5	DRIVER DOOR LOCK MOTOR DRIVE – UNLOCK: TO ACTIVATE, GECM SWITCHES CIRCUIT TO B+
I IP5-16	TRUNK RELEASE SWITCH: GROUND WHEN SELECTED
S IP5-18	SCP –
S IP5-19	SCP +
SG IP6-1	LOGIC GROUND: GROUND
I IP6-8	KEY-IN IGNITION SWITCH: B+ WHEN KEY IN
I IP6-21	PASSENGER DOOR AJAR: DOOR OPEN = OPEN CIRCUIT; DOOR CLOSED = GROUND
I IP6-22	DRIVER DOOR AJAR: DOOR OPEN = OPEN CIRCUIT; DOOR CLOSED = GROUND
B+ JB172-1	BATTERY POWER SUPPLY (LOCKING): B+

Instrument Cluster

Pin	Description and Characteristic
I IP10-13	EMERGENCY UNLOCK: B+ WHEN ACTIVATED
S IP10-22	SCP +
S IP10-23	SCP –
I IP11-7	BATTERY POWER SUPPLY: B+
I IP11-8	POWER GROUND: GROUND

NOTE: Refer to the Appendix at the rear of this book for Network Messages.

COMPONENTS

Component	Connector(s)	Connector Description	Location
DOOR LATCH ASSEMBLY – LH FRONT	FL3 FL9	8-WAY / BLACK 2-WAY / BLACK	LH FRONT DOOR
DOOR LATCH ASSEMBLY – LH REAR	BL3 BL6	8-WAY / BLACK 2-WAY / BLACK	LH REAR DOOR
DOOR LATCH ASSEMBLY – RH FRONT	FR3 FR9	8-WAY / BLACK 2-WAY / BLACK	RH FRONT DOOR
DOOR LATCH ASSEMBLY – RH REAR	BR3 BR6	8-WAY / BLACK 2-WAY / BLACK	RH REAR DOOR
GENERAL ELECTRONIC CONTROL MODULE	CA86 CA87 IP5 IP6 JB172	23-WAY / GREY 23-WAY / GREEN 23-WAY / BROWN 23-WAY / WHITE 23-WAY / BLUE	BEHIND INSTRUMENT PANEL RH SIDE
IGNITION SWITCH	IP18	7-WAY / BLACK	STEERING COLUMN
INERTIA SWITCH	IP132	3-WAY / BLACK	LOWER RH A POST
INSTRUMENT CLUSTER	IP10 IP11	26-WAY / YELLOW 26-WAY / YELLOW	INSTRUMENT PANEL
TRUNK LOCK MOTOR	TM6	5-WAY / NATURAL	TRUNK LID
TRUNK RELEASE SWITCH	TM8	2-WAY / WHITE	TRUNK LID

HARNESS IN-LINE CONNECTORS

Connector	Connector Description	Location
CA1	22-WAY / NATURAL / CABIN HARNESS TO INSTRUMENT PANEL HARNESS	LH LOWER A POST
CA15	20-WAY / BLACK / DOOR HARNESS TO CABIN HARNESS	DRIVER SIDE A POST
CA16	20-WAY / BLACK / DOOR HARNESS TO CABIN HARNESS	DRIVER SIDE A POST
CA20	20-WAY / BLACK / DOOR HARNESS TO CABIN HARNESS	DRIVER SIDE A POST
CA21	20-WAY / BLACK / DOOR HARNESS TO CABIN HARNESS	DRIVER SIDE A POST
CA25	14-WAY / NATURAL / REAR DOOR HARNESS TO CABIN HARNESS	LH B/C POST
CA30	14-WAY / NATURAL / DOOR LOCK LINK LEAD	RH B/C POST
CA45	6-WAY / GREY / CABIN HARNESS TO TRUNK LID HARNESS	TRUNK LH REAR
TL10	6-WAY / GREY / TRUNK LID HARNESS	BELOW PARCEL SHELF LH SIDE

GROUNDINGS

Ground	Location
G1	TRUNK / LH REAR
G4	PASSENGER COMPARTMENT / RH LOWER A POST
G15	PASSENGER COMPARTMENT / LH LOWER A POST
G36	PASSENGER COMPARTMENT / RH CROSS CAR BEAM
G37	PASSENGER COMPARTMENT / LH CROSS CAR BEAM

FOR CONTROL MODULE PIN-OUT INFORMATION, UNFOLD PAGE TO LEFT.

The following abbreviations are used to represent values for Control Module Pin-Out data

I	Input	PG	Power Ground	CAN	CAN Network	D	Serial and Encoded Data
O	Output	SS	Sensor / Signal Supply V	SCP	SCP Network	V	Voltage (DC)
B+	Battery Voltage	SG	Sensor / Signal Ground	D2	D2B Network	PWM	Pulse Width Modulated

CAUTION: The information on this data page is furnished to aid the user in understanding circuit operation. THIS INFORMATION SHOULD BE USED FOR REFERENCE ONLY.

NOTE: The characteristics listed are approximately those that can be expected at the control module connector pins with all circuit connections made and all components connected and fitted.

Refer to the front of this book for detailed information and illustrations regarding the location and identification of harnesses, relays, fuses, grounds, control modules and control module pins.

CONTROL MODULE PIN-OUT INFORMATION

General Electronic Control Module

Pin	Description and Characteristic
PG	CA86-5 POWER GROUND: GROUND
I	CA86-14 RESET SWITCH: OPEN CIRCUIT / GROUND
I	CA86-16 SET SWITCH: OPEN CIRCUIT / GROUND
I	CA86-18 RH REAR DOOR AJAR: DOOR OPEN = OPEN CIRCUIT; DOOR CLOSED = GROUND
I	CA86-19 LOCK SWITCH: OPEN CIRCUIT / GROUND
I	CA86-22 TRUNK LID AJAR: TRUNK OPEN = OPEN CIRCUIT; TRUNK CLOSED = GROUND
O	CA87-2 TRUNK LOCK MOTOR DRIVE: TO ACTIVATE, GECM SWITCHES CIRCUIT TO B+
O	CA87-3 CENTRAL LOCKING MOTORS DRIVE - LOCK: TO ACTIVATE, GECM SWITCHES CIRCUIT TO B+
O	CA87-5 CENTRAL LOCKING REAR MOTORS DRIVE - UNLOCK: TO ACTIVATE, GECM SWITCHES CIRCUIT TO B+
I	CA87-15 LH REAR DOOR AJAR: DOOR OPEN = OPEN CIRCUIT; DOOR CLOSED = GROUND
I	CA87-16 UNLOCK SWITCH: OPEN CIRCUIT / GROUND
O	IP5-1 PASSENGER DOORS LOCK MOTOR DRIVE - UNLOCK: TO ACTIVATE, GECM SWITCHES CIRCUIT TO B+
I	IP5-3 EXTERNAL ANTENNA
O	IP5-5 DRIVER DOOR LOCK MOTOR DRIVE - UNLOCK: TO ACTIVATE, GECM SWITCHES CIRCUIT TO B+
I	IP5-16 TRUNK RELEASE SWITCH: GROUND WHEN SELECTED
S	IP5-18 SCP -
S	IP5-19 SCP +
SG	IP6-1 LOGIC GROUND: GROUND
I	IP6-8 KEY-IN IGNITION SWITCH: B+ WHEN KEY IN
I	IP6-21 PASSENGER DOOR AJAR: DOOR OPEN = OPEN CIRCUIT; DOOR CLOSED = GROUND
I	IP6-22 DRIVER DOOR AJAR: DOOR OPEN = OPEN CIRCUIT; DOOR CLOSED = GROUND
B+	JB172-1 BATTERY POWER SUPPLY (LOCKING): B+

Instrument Cluster

Pin	Description and Characteristic
I	IP10-13 EMERGENCY UNLOCK: B+ WHEN ACTIVATED
S	IP10-22 SCP +
S	IP10-23 SCP -
I	IP11-7 BATTERY POWER SUPPLY: B+
I	IP11-8 POWER GROUND: GROUND

NOTE: Refer to the Appendix at the rear of this book for Network Messages.

The following abbreviations are used to represent values for Control Module Pin-Out data

I	Input	PG	Power Ground	CAN	CAN Network	D	Serial and Encoded Data
O	Output	SS	Sensor / Signal Supply V	SCP	SCP Network	V	Voltage (DC)
B+	Battery Voltage	SG	Sensor / Signal Ground	D2	D2B Network	PWM	Pulse Width Modulated

CAUTION: The information on this data page is furnished to aid the user in understanding circuit operation. THIS INFORMATION SHOULD BE USED FOR REFERENCE ONLY.

NOTE: The characteristics listed are approximately those that can be expected at the control module connector pins with all circuit connections made and all components connected and fitted.

Fig. 12.2

COMPONENTS

Component	Connector(s)	Connector Description	Location
DOOR LATCH ASSEMBLY - LH FRONT	FL3 FL9	8-WAY / BLACK 2-WAY / BLACK	LH FRONT DOOR
DOOR LATCH ASSEMBLY - LH REAR	BL3 BL6	8-WAY / BLACK 2-WAY / BLACK	LH REAR DOOR
DOOR LATCH ASSEMBLY - RH FRONT	FR3 FR9	8-WAY / BLACK 2-WAY / BLACK	RH FRONT DOOR
DOOR LATCH ASSEMBLY - RH REAR	BR3 BR6	8-WAY / BLACK 2-WAY / BLACK	RH REAR DOOR
GENERAL ELECTRONIC CONTROL MODULE	CA86 CA87 IP5 IP6 JB172	23-WAY / GREY 23-WAY / GREEN 23-WAY / BROWN 23-WAY / WHITE 23-WAY / BLUE	BEHIND INSTRUMENT PANEL RH SIDE
IGNITION SWITCH	IP18	7-WAY / BLACK	STEERING COLUMN
INERTIA SWITCH	IP132	3-WAY / BLACK	LOWER RH A POST
INSTRUMENT CLUSTER	IP10 IP11	26-WAY / YELLOW 26-WAY / YELLOW	INSTRUMENT PANEL
TRUNK LOCK MOTOR	TM6	5-WAY / NATURAL	TRUNK LID
TRUNK RELEASE SWITCH	TM8	2-WAY / WHITE	TRUNK LID

HARNESS IN-LINE CONNECTORS

Connector	Connector Description	Location
CA1	22-WAY / NATURAL / CABIN HARNESS TO INSTRUMENT PANEL HARNESS	LH LOWER A POST
CA15	20-WAY / BLACK / DOOR HARNESS TO CABIN HARNESS	DRIVER SIDE A POST
CA16	20-WAY / BLACK / DOOR HARNESS TO CABIN HARNESS	DRIVER SIDE A POST
CA20	20-WAY / BLACK / DOOR HARNESS TO CABIN HARNESS	DRIVER SIDE A POST
CA21	20-WAY / BLACK / DOOR HARNESS TO CABIN HARNESS	DRIVER SIDE A POST
CA25	14-WAY / NATURAL / REAR DOOR HARNESS TO CABIN HARNESS	LH B/C POST
CA30	14-WAY / NATURAL / DOOR LOCK LINK LEAD	RH B/C POST
CA45	6-WAY / GREY / CABIN HARNESS TO TRUNK LID HARNESS	TRUNK LH REAR
TL10	6-WAY / GREY / TRUNK LID HARNESS	BELOW PARCEL SHELF LH SIDE

GROUNDINGS

Ground	Location
G1	TRUNK / LH REAR
G4	PASSENGER COMPARTMENT / RH LOWER A POST
G15	PASSENGER COMPARTMENT / LH LOWER A POST
G36	PASSENGER COMPARTMENT / RH CROSS CAR BEAM
G37	PASSENGER COMPARTMENT / LH CROSS CAR BEAM

FOR CONTROL MODULE PIN-OUT INFORMATION, UNFOLD PAGE TO LEFT.

Refer to the front of this book for detailed information and illustrations regarding the location and identification of harnesses, relays, fuses, grounds, control modules and control module pins.

CONTROL MODULE PIN-OUT INFORMATION

General Electronic Control Module

Pin	Description and Characteristic
PG	CA86-5 POWER GROUND: GROUND
I	CA86-17 INCLINATION SENSOR SENSE: ALARM TRIGGERED = GROUND; ALARM NOT TRIGGERED = B+
I	CA86-18 RH REAR DOOR AJAR: DOOR OPEN = OPEN CIRCUIT; DOOR CLOSED = GROUND
I	CA86-19 LOCK SWITCH: OPEN CIRCUIT / GROUND
O	CA86-20 INCLINATION AND INTRUSION SENSORS POWER SUPPLY: B+
I	CA86-22 TRUNK LID AJAR: TRUNK OPEN = OPEN CIRCUIT; TRUNK CLOSED = GROUND
I	CA86-23 INTRUSION SENSOR SENSE: ALARM TRIGGERED = GROUND; ALARM NOT TRIGGERED = B+
O	CA87-1 PASSIVE SECURITY SOUNDER DRIVE: TO ACTIVATE, GECC SWITCHES CIRCUIT TO B+
O	CA87-2 TRUNK LOCK MOTOR DRIVE: TO ACTIVATE, GECC SWITCHES CIRCUIT TO B+
I	CA87-15 LH REAR DOOR AJAR: DOOR OPEN = OPEN CIRCUIT; DOOR CLOSED = GROUND
I	IP5-3 EXTERNAL ANTENNA
O	IP5-14 HORN RELAY DRIVE : TO ACTIVATE, GECC SWITCHES CIRCUIT TO GROUND
I	IP5-16 TRUNK RELEASE SWITCH: GROUND WHEN SELECTED
S	IP5-18 SCP -
S	IP5-19 SCP +
SG	IP6-1 LOGIC GROUND: GROUND
I	IP6-8 KEY-IN IGNITION SWITCH: B+ WHEN KEY IN
I	IP6-9 HEADLAMP FLASH SWITCH: GROUND WHEN SELECTED
I	IP6-10 AUDIO UNIT PRESENCE SENSE: GROUND WHEN RADIO INSTALLED
I	IP6-21 PASSENGER DOOR AJAR: DOOR OPEN = OPEN CIRCUIT; DOOR CLOSED = GROUND
I	IP6-22 DRIVER DOOR AJAR: DOOR OPEN = OPEN CIRCUIT; DOOR CLOSED = GROUND
B+	JB172-1 BATTERY POWER SUPPLY (LOCKING): B+
O	JB172-3 RH FRONT TURN SIGNAL: TO ACTIVATE, GECC SWITCHES CIRCUIT TO B+
O	JB172-4 LH FRONT TURN SIGNAL: TO ACTIVATE, GECC SWITCHES CIRCUIT TO B+
B+	JB172-5 BATTERY POWER SUPPLY (TURN SIGNALS): B+
D	JB172-18 ACTIVE SECURITY SOUNDER DRIVE: ENCODED COMMUNICATIONS
I	JB172-21 HOOD AJAR: HOOD OPEN = OPEN CIRCUIT; HOOD CLOSED = GROUND

Instrument Cluster

Pin	Description and Characteristic
O	IP10-2 SECURITY INDICATOR DRIVE: TO ACTIVATE, IC SWITCHES CIRCUIT TO B+
D	IP10-3 PATS 1: ENCODED COMMUNICATION
D	IP10-4 PATS 2: ENCODED COMMUNICATION
I	IP10-5 PATS GROUND: GROUND
O	IP10-6 PATS TRANSCEIVER POWER: B+
C	IP10-17 CAN +
C	IP10-18 CAN -
S	IP10-22 SCP +
S	IP10-23 SCP -
I	IP11-7 BATTERY POWER SUPPLY: B+
I	IP11-8 POWER GROUND: GROUND
I	IP11-11 IGNITION SWITCHED POWER SUPPLY (III): B+

NOTE: Refer to the Appendix at the rear of this book for Network Messages.

The following abbreviations are used to represent values for Control Module Pin-Out data

I	Input	PG	Power Ground	CAN	CAN Network	D	Serial and Encoded Data
O	Output	SS	Sensor / Signal Supply V	SCP	SCP Network	V	Voltage (DC)
B+	Battery Voltage	SG	Sensor / Signal Ground	D2	D2B Network	PWM	Pulse Width Modulated

CAUTION: The information on this data page is furnished to aid the user in understanding circuit operation. THIS INFORMATION SHOULD BE USED FOR REFERENCE ONLY.

NOTE: The characteristics listed are approximately those that can be expected at the control module connector pins with all circuit connections made and all components connected and fitted.

Fig. 12.3

COMPONENTS

Component	Connector(s)	Connector Description	Location
ACTIVE SECURITY SOUNDER	JB70	6-WAY / BLACK	BEHIND FRONT LH WHEEL ARCH LINER
AUDIO UNIT	ID1	2-WAY / BLACK	INSTRUMENT PANEL CENTER
	IP65	20-WAY / BLACK	
	IP106	2-WAY / COAXIAL	
ENGINE CONTROL MODULE (2.0L)	EN65	104-WAY / BLACK	ENGINE COMPARTMENT, FRONT BULKHEAD RH SIDE
ENGINE CONTROL MODULE (2.5L & 3.0L)	EN16	134-WAY / BLACK	ENGINE COMPARTMENT, FRONT BULKHEAD RH SIDE
DOOR LATCH ASSEMBLY - LH FRONT	FL3	8-WAY / BLACK	LH FRONT DOOR
	FL9	2-WAY / BLACK	
DOOR LATCH ASSEMBLY - LH REAR	BL3	8-WAY / BLACK	LH REAR DOOR
	BL6	2-WAY / BLACK	
DOOR LATCH ASSEMBLY - RH FRONT	FR3	8-WAY / BLACK	RH FRONT DOOR
	FR9	2-WAY / BLACK	
DOOR LATCH ASSEMBLY - RH REAR	BR3	8-WAY / BLACK	RH REAR DOOR
	BR6	2-WAY / BLACK	
GENERAL ELECTRONIC CONTROL MODULE	CA86	23-WAY / GREY	BEHIND INSTRUMENT PANEL RH SIDE
	CA87	23-WAY / GREEN	
	IP5	23-WAY / BROWN	
	IP6	23-WAY / WHITE	
	JB172	23-WAY / BLUE	
HOOD SECURITY SWITCH	JB81	2-WAY / BLACK	ADJACENT TO RH FRONT SUSPENSION TURRET
HORN RELAY	—	—	POWER DISTRIBUTION FUSE BOX R3
HORNS	JB87	2-WAY / BLACK	ADJACENT TO BATTERY
IGNITION SWITCH	IP18	7-WAY / BLACK	STEERING COLUMN
INCLINATION SENSOR	CA190	6-WAY / BLACK	TRUNK LH REAR
INSTRUMENT CLUSTER	IP10	26-WAY / YELLOW	INSTRUMENT PANEL
	IP11	26-WAY / YELLOW	
PASSIVE ANTI-THEFT SYSTEM TRANSCEIVER	IP15	4-WAY / GREEN	STEERING COLUMN, IGNITION SWITCH
PASSIVE SECURITY SOUNDER	SL1	1-WAY	LH FRONT OF VEHICLE
	SL2	1-WAY	
POWER DISTRIBUTION FUSE BOX	—	—	ENGINE COMPARTMENT LH SIDE
ROOF CONSOLE	RC22	22-WAY / BLACK	ROOF, CENTER FRONT
	RC30	4-WAY / BLACK	
	RC31	2-WAY / BLACK	
	RC33	4-WAY / BLACK	
	RC34	6-WAY / BLACK	
SECURITY INDICATOR	IP29	6-WAY / BLACK	CENTER CONSOLE
TRUNK LOCK MOTOR	TM6	5-WAY / NATURAL	TRUNK LID

HARNESS IN-LINE CONNECTORS

Connector	Connector Description	Location
CA1	22-WAY / NATURAL / CABIN HARNESS TO INSTRUMENT PANEL HARNESS	LH LOWER A POST
CA15	20-WAY / BLACK / DOOR HARNESS TO CABIN HARNESS	DRIVER SIDE A POST
CA20	20-WAY / BLACK / DOOR HARNESS TO CABIN HARNESS	DRIVER SIDE A POST
CA25	14-WAY / NATURAL / REAR DOOR HARNESS TO CABIN HARNESS	LH B/C POST
CA30	14-WAY / NATURAL / DOOR LOCK LINK LEAD	RH B/C POST
CA36	16-WAY / GREEN / CABIN HARNESS TO ROOF HARNESS	LH LOWER A POST
CA45	6-WAY / GREY / CABIN HARNESS TO TRUNK LID HARNESS	TRUNK LH REAR
CA170	16-WAY / GREEN / IN-LINE CONNECTOR	LH LOWER A POST
JB79	6-WAY / BLACK / SECURITY SOUNDER LINK LEAD	BEHIND FRONT LH WHEELARCH LINER
JB129	22-WAY / GREY / INSTRUMENT PANEL HARNESS TO JUNCTION BOX HARNESS	LH LOWER A POST
TL10	6-WAY / GREY / TRUNK LID HARNESS	BELOW PARCEL SHELF LH SIDE

GROUNDINGS

Ground	Location
G1	TRUNK / LH REAR
G4	PASSENGER COMPARTMENT / RH LOWER A POST
G5	PASSENGER COMPARTMENT / RH LOWER A POST
G11	ENGINE COMPARTMENT / UNDER LH HEADLAMP ASSEMBLY
G14	ENGINE COMPARTMENT / REARWARD OF POWER DISTRIBUTION FUSE BOX
G15	PASSENGER COMPARTMENT / LH LOWER A POST
G36	PASSENGER COMPARTMENT / RH CROSS CAR BEAM
G37	PASSENGER COMPARTMENT / LH CROSS CAR BEAM

FOR CONTROL MODULE PIN-OUT INFORMATION, UNFOLD PAGE TO LEFT.

Refer to the front of this book for detailed information and illustrations regarding the location and identification of harnesses, relays, fuses, grounds, control modules and control module pins.

CONTROL MODULE PIN-OUT INFORMATION

General Electronic Control Module

Pin	Description and Characteristic
PG CA86-5	POWER GROUND: GROUND
I IP5-4	INTERMITTENT WIPE INTERVAL: 1 = 0.5 – 4 kΩ; 2 = 4 – 14 kΩ; 3 = 14 – 24 kΩ; 4 = 24 – 34 kΩ; 5 = 34 – 43 kΩ; 6 = 43 – 57 kΩ
S IP5-18	SCP –
S IP5-19	SCP +
O IP5-21	WINDSHIELD WIPER RELAY DRIVE: TO ACTIVATE, CIRCUIT SWITCHED TO GROUND
SG IP6-1	LOGIC GROUND: GROUND
I IP6-4	INTERMITTENT WIPE: B+ WHEN SELECTED
I IP6-5	WASHER SWITCH: WASHER ON = GROUND; WASHER OFF = B+
B+ JB172-1	BATTERY POWER SUPPLY (LOCKING): B+
I JB172-2	WIPER MOTOR PARK SWITCH: PARKED = GROUND; NOT PARKED = B+
B+ JB172-5	BATTERY POWER SUPPLY (TURN SIGNALS): B+
O JB172-23	POWER WASH PUMP RELAY DRIVE: TO ACTIVATE, GECM SWITCHES CIRCUIT TO GROUND

NOTE: Refer to the Appendix at the rear of this book for Network Messages.

Fig. 13.1

COMPONENTS

Component	Connector(s)	Connector Description	Location
GENERAL ELECTRONIC CONTROL MODULE	CA86 CA87 IP5 IP6 JB172	23-WAY / GREY 23-WAY / GREEN 23-WAY / BROWN 23-WAY / WHITE 23-WAY / BLUE	BEHIND INSTRUMENT PANEL RH SIDE
POWER DISTRIBUTION FUSE BOX	—	—	ENGINE COMPARTMENT LH SIDE
POWER WASH PUMP	JB65	2-WAY / GREY	BEHIND RH FRONT WHEEL ARCH LINER
POWER WASH PUMP RELAY	—	—	POWER DISTRIBUTION FUSE BOX R5
WINDSHIELD WASHER PUMP	JB109	2-WAY / WHITE	ENGINE COMPARTMENT RH FRONT
WINDSHIELD WIPER MOTOR RELAY	—	—	POWER DISTRIBUTION FUSE BOX R1
WIPER MOTOR ASSEMBLY	JB63	5-WAY / BLACK	BASE OF WINDSHIELD LH SIDE
WIPER SWITCH ASSEMBLY	IP16	10-WAY / GREY	STEERING COLUMN

HARNES IN-LINE CONNECTORS

Connector	Connector Description	Location
JB3	14-WAY / BLUE / JUNCTION BOX HARNESS TO INSTRUMENT PANEL HARNESS	BELOW INSTRUMENT PANEL LH SIDE
JB129	22-WAY / GREY / INSTRUMENT PANEL HARNESS TO JUNCTION BOX HARNESS	LH LOWER A POST
JB130	22-WAY / GREEN / JUNCTION BOX HARNESS TO INSTRUMENT PANEL HARNESS	ADJACENT TO CENTRAL JUNCTION FUSE BOX

GROUNDS

Ground	Location
G4	PASSENGER COMPARTMENT / RH LOWER A POST
G5	PASSENGER COMPARTMENT / RH LOWER A POST
G10	ENGINE COMPARTMENT / UNDER RH HEADLAMP ASSEMBLY
G14	ENGINE COMPARTMENT / REARWARD OF POWER DISTRIBUTION FUSE BOX
G36	PASSENGER COMPARTMENT / RH CROSS CAR BEAM
G37	PASSENGER COMPARTMENT / LH CROSS CAR BEAM

FOR CONTROL MODULE PIN-OUT INFORMATION, UNFOLD PAGE TO LEFT.

The following abbreviations are used to represent values for Control Module Pin-Out data

I	Input	PG	Power Ground	CAN	CAN Network	D	Serial and Encoded Data
O	Output	SS	Sensor / Signal Supply V	SCP	SCP Network	V	Voltage (DC)
B+	Battery Voltage	SG	Sensor / Signal Ground	D2	D2B Network	PWM	Pulse Width Modulated

CAUTION: The information on this data page is furnished to aid the user in understanding circuit operation. THIS INFORMATION SHOULD BE USED FOR REFERENCE ONLY.

NOTE: The characteristics listed are approximately those that can be expected at the control module connector pins with all circuit connections made and all components connected and fitted.

Refer to the front of this book for detailed information and illustrations regarding the location and identification of harnesses, relays, fuses, grounds, control modules and control module pins.

Fig. 13.2

General Electronic Control Module

Pin	Description and Characteristic
PG CA86-5	POWER GROUND: GROUND
I IP5-4	INTERMITTENT WIPE INTERVAL: 1 = 0.5 – 4 kΩ; 2 = 4 – 14 kΩ; 3 = 14 – 24 kΩ; 4 = 24 – 34 kΩ; 5 = 34 – 43 kΩ; 6 = 43 – 57 kΩ
S IP5-18	SCP –
S IP5-19	SCP +
O IP5-21	WINDSHIELD WIPER RELAY DRIVE: TO ACTIVATE, CIRCUIT SWITCHED TO GROUND
SG IP6-1	LOGIC GROUND: GROUND
I IP6-4	INTERMITTENT WIPE: B+ WHEN SELECTED
I IP6-5	WASHER SWITCH: WASHER ON = GROUND; WASHER OFF = B+
B+ JB172-1	BATTERY POWER SUPPLY (LOCKING): B+
I JB172-2	WIPER MOTOR PARK SWITCH: PARKED = GROUND; NOT PARKED = B+
B+ JB172-5	BATTERY POWER SUPPLY (TURN SIGNALS): B+
O JB172-23	POWER WASH PUMP RELAY DRIVE: TO ACTIVATE, GECM SWITCHES CIRCUIT TO GROUND

NOTE: Refer to the Appendix at the rear of this book for Network Messages.

COMPONENTS

Component	Connector(s)	Connector Description	Location
GENERAL ELECTRONIC CONTROL MODULE	CA86 CA87 IP5 IP6 JB172	23-WAY / GREY 23-WAY / GREEN 23-WAY / BROWN 23-WAY / WHITE 23-WAY / BLUE	BEHIND INSTRUMENT PANEL RH SIDE
POWER DISTRIBUTION FUSE BOX	—	—	ENGINE COMPARTMENT LH SIDE
POWER WASH PUMP	JB65	2-WAY / GREY	BEHIND RH FRONT WHEEL ARCH LINER
POWER WASH PUMP RELAY	—	—	POWER DISTRIBUTION FUSE BOX R5
RAIN SENSING CONTROL MODULE	CA6	12-WAY / BLACK	BEHIND INSTRUMENT PANEL LH SIDE
RAIN SENSOR	RC15	3-WAY / BLACK	BEHIND REAR VIEW MIRROR
WINDSHIELD WASHER PUMP	JB109	2-WAY / WHITE	ENGINE COMPARTMENT RH FRONT
WINDSHIELD WIPER MOTOR RELAY	—	—	POWER DISTRIBUTION FUSE BOX R1
WIPER MOTOR ASSEMBLY	JB63	5-WAY / BLACK	BASE OF WINDSHIELD LH SIDE
WIPER SWITCH ASSEMBLY	IP16	10-WAY / GREY	STEERING COLUMN

HARNESS IN-LINE CONNECTORS

Connector	Connector Description	Location
CA10	22-WAY / GREY / ENGINE HARNESS TO CABIN HARNESS	BELOW THE GLOVEBOX
CA35	10-WAY / GREY / CABIN HARNESS TO ROOF HARNESS	RH LOWER A POST
CA241	22-WAY / GREEN / INSTRUMENT PANEL HARNESS TO CABIN HARNESS	ADJACENT TO CENTRAL JUNCTION FUSE BOX
JB3	14-WAY / BLUE / JUNCTION BOX HARNESS TO INSTRUMENT PANEL HARNESS	BELOW INSTRUMENT PANEL LH SIDE
JB129	22-WAY / GREY / INSTRUMENT PANEL HARNESS TO JUNCTION BOX HARNESS	LH LOWER A POST
JB130	22-WAY / GREEN / JUNCTION BOX HARNESS TO INSTRUMENT PANEL HARNESS	ADJACENT TO CENTRAL JUNCTION FUSE BOX

GROUND S

Ground	Location
G4	PASSENGER COMPARTMENT / RH LOWER A POST
G5	PASSENGER COMPARTMENT / RH LOWER A POST
G10	ENGINE COMPARTMENT / UNDER RH HEADLAMP ASSEMBLY
G14	ENGINE COMPARTMENT / REARWARD OF POWER DISTRIBUTION FUSE BOX
G15	PASSENGER COMPARTMENT / LH LOWER A POST
G36	PASSENGER COMPARTMENT / RH CROSS CAR BEAM
G37	PASSENGER COMPARTMENT / LH CROSS CAR BEAM

FOR CONTROL MODULE PIN-OUT INFORMATION, UNFOLD PAGE TO LEFT.

The following abbreviations are used to represent values for Control Module Pin-Out data

I	Input	PG	Power Ground	CAN	CAN Network	D	Serial and Encoded Data
O	Output	SS	Sensor / Signal Supply V	SCP	SCP Network	V	Voltage (DC)
B+	Battery Voltage	SG	Sensor / Signal Ground	D2	D2B Network	PWM	Pulse Width Modulated

CAUTION: The information on this data page is furnished to aid the user in understanding circuit operation. THIS INFORMATION SHOULD BE USED FOR REFERENCE ONLY.

NOTE: The characteristics listed are approximately those that can be expected at the control module connector pins with all circuit connections made and all components connected and fitted.

Refer to the front of this book for detailed information and illustrations regarding the location and identification of harnesses, relays, fuses, grounds, control modules and control module pins.

General Electronic Control Module

Pin	Description and Characteristic
I	CA86-16 SET SWITCH: OPEN CIRCUIT / GROUND
O	CA87-17 GLOBAL CLOSE REQUEST: 20 ms PULSED SIGNAL
I	IP5-3 EXTERNAL ANTENNA
SG	IP6-1 LOGIC GROUND: GROUND
B+	JB172-1 BATTERY POWER SUPPLY (LOCKING): B+

COMPONENTS

Component	Connector(s)	Connector Description	Location
DOOR LATCH ASSEMBLY – LH FRONT	FL3 FL9	8-WAY / BLACK 2-WAY / BLACK	LH FRONT DOOR
DOOR SWITCH PACK – DRIVER (LHD)	FL1	20-WAY / BLACK	DRIVER DOOR ARM REST
DOOR SWITCH PACK – LH REAR	BL1	8-WAY / BLACK	LH REAR DOOR
DOOR SWITCH PACK – PASSENGER (LHD)	FR10	8-WAY / BLACK	PASSENGER DOOR
DOOR SWITCH PACK – RH REAR	BR1	8-WAY / BLACK	RH REAR DOOR
GENERAL ELECTRONIC CONTROL MODULE	CA86 CA87 IP5 IP6 JB172	23-WAY / GREY 23-WAY / GREEN 23-WAY / BROWN 23-WAY / WHITE 23-WAY / BLUE	BEHIND INSTRUMENT PANEL RH SIDE
WINDOW MOTOR ASSEMBLY – LH FRONT	FL2	8-WAY / GREY	LH FRONT DOOR
WINDOW MOTOR ASSEMBLY – LH REAR	BL2	8-WAY / GREY	LH REAR DOOR
WINDOW MOTOR ASSEMBLY – RH FRONT	FR2	8-WAY / GREY	RH FRONT DOOR
WINDOW MOTOR ASSEMBLY – RH REAR	BR2	8-WAY / GREY	RH REAR DOOR

HARNES IN-LINE CONNECTORS

Connector	Connector Description	Location
CA15	20-WAY / BLACK / DOOR HARNES TO CABIN HARNES	DRIVER SIDE A POST
CA16	20-WAY / BLACK / DOOR HARNES TO CABIN HARNES	DRIVER SIDE A POST
CA20	20-WAY / BLACK / DOOR HARNES TO CABIN HARNES	DRIVER SIDE A POST
CA25	14-WAY / NATURAL / REAR DOOR HARNES TO CABIN HARNES	LH B/C POST
CA30	14-WAY / NATURAL / DOOR LOCK LINK LEAD	RH B/C POST

GROUNDS

Ground	Location
G4	PASSENGER COMPARTMENT / RH LOWER A POST
G5	PASSENGER COMPARTMENT / RH LOWER A POST
G15	PASSENGER COMPARTMENT / LH LOWER A POST

FOR CONTROL MODULE PIN-OUT INFORMATION, UNFOLD PAGE TO LEFT.

The following abbreviations are used to represent values for Control Module Pin-Out data

I	Input	PG	Power Ground	CAN	CAN Network	D	Serial and Encoded Data
O	Output	SS	Sensor / Signal Supply V	SCP	SCP Network	V	Voltage (DC)
B+	Battery Voltage	SG	Sensor / Signal Ground	D2	D2B Network	PWM	Pulse Width Modulated

CAUTION: The information on this data page is furnished to aid the user in understanding circuit operation. THIS INFORMATION SHOULD BE USED FOR REFERENCE ONLY.

NOTE: The characteristics listed are approximately those that can be expected at the control module connector pins with all circuit connections made and all components connected and fitted.

Refer to the front of this book for detailed information and illustrations regarding the location and identification of harnesses, relays, fuses, grounds, control modules and control module pins.

General Electronic Control Module

Pin	Description and Characteristic
I	CA86-16 SET SWITCH: OPEN CIRCUIT / GROUND
O	CA87-17 GLOBAL CLOSE REQUEST: 20 ms PULSED SIGNAL
I	IP5-3 EXTERNAL ANTENNA
SG	IP6-1 LOGIC GROUND: GROUND
B+	JB172-1 BATTERY POWER SUPPLY (LOCKING): B+

COMPONENTS

Component	Connector(s)	Connector Description	Location
DOOR LATCH ASSEMBLY – LH FRONT	FL3 FL9	8-WAY / BLACK 2-WAY / BLACK	LH FRONT DOOR
DOOR SWITCH PACK – DRIVER (LHD)	FL1	20-WAY / BLACK	DRIVER DOOR ARM REST
DOOR SWITCH PACK – LH REAR	BL1	8-WAY / BLACK	LH REAR DOOR
DOOR SWITCH PACK – PASSENGER (LHD)	FR10	8-WAY / BLACK	PASSENGER DOOR
DOOR SWITCH PACK – RH REAR	BR1	8-WAY / BLACK	RH REAR DOOR
GENERAL ELECTRONIC CONTROL MODULE	CA86 CA87 IP5 IP6 JB172	23-WAY / GREY 23-WAY / GREEN 23-WAY / BROWN 23-WAY / WHITE 23-WAY / BLUE	BEHIND INSTRUMENT PANEL RH SIDE
WINDOW MOTOR ASSEMBLY – LH FRONT	FL2	8-WAY / GREY	LH FRONT DOOR
WINDOW MOTOR ASSEMBLY – LH REAR	BL2	8-WAY / GREY	LH REAR DOOR
WINDOW MOTOR ASSEMBLY – RH FRONT	FR2	8-WAY / GREY	RH FRONT DOOR
WINDOW MOTOR ASSEMBLY – RH REAR	BR2	8-WAY / GREY	RH REAR DOOR

HARNES IN-LINE CONNECTORS

Connector	Connector Description	Location
CA15	20-WAY / BLACK / DOOR HARNES TO CABIN HARNES	DRIVER SIDE A POST
CA20	20-WAY / BLACK / DOOR HARNES TO CABIN HARNES	DRIVER SIDE A POST
CA21	20-WAY / BLACK / DOOR HARNES TO CABIN HARNES	DRIVER SIDE A POST
CA25	14-WAY / NATURAL / REAR DOOR HARNES TO CABIN HARNES	LH B/C POST
CA30	14-WAY / NATURAL / DOOR LOCK LINK LEAD	RH B/C POST

GROUNDS

Ground	Location
G4	PASSENGER COMPARTMENT / RH LOWER A POST
G5	PASSENGER COMPARTMENT / RH LOWER A POST
G15	PASSENGER COMPARTMENT / LH LOWER A POST

FOR CONTROL MODULE PIN-OUT INFORMATION, UNFOLD PAGE TO LEFT.

The following abbreviations are used to represent values for Control Module Pin-Out data

I	Input	PG	Power Ground	CAN	CAN Network	D	Serial and Encoded Data
O	Output	SS	Sensor / Signal Supply V	SCP	SCP Network	V	Voltage (DC)
B+	Battery Voltage	SG	Sensor / Signal Ground	D2	D2B Network	PWM	Pulse Width Modulated

CAUTION: The information on this data page is furnished to aid the user in understanding circuit operation. THIS INFORMATION SHOULD BE USED FOR REFERENCE ONLY.

NOTE: The characteristics listed are approximately those that can be expected at the control module connector pins with all circuit connections made and all components connected and fitted.

Refer to the front of this book for detailed information and illustrations regarding the location and identification of harnesses, relays, fuses, grounds, control modules and control module pins.

CONTROL MODULE PIN-OUT INFORMATION

Control Module

Pin	Description and Characteristic
I CA86-16	SET SWITCH: OPEN CIRCUIT / GROUND
O CA87-17	GLOBAL CLOSE REQUEST: 20 ms PULSED SIGNAL
O CA87-20	VEHICLE SPEED SIGNAL: PULSED SIGNAL, 8000 PULSES PER MPH
I IP5-3	EXTERNAL ANTENNA
S IP5-18	SCP -
S IP5-19	SCP +
SG IP6-1	LOGIC GROUND: GROUND
B+ JB172-1	BATTERY POWER SUPPLY (LOCKING): B+

NOTE: Refer to the Appendix at the rear of this book for Network Messages.

Fig. 14.3

COMPONENTS

Component	Connector(s)	Connector Description	Location
GENERAL ELECTRONIC CONTROL MODULE	CA86 CA87 IP5 IP6 JB172	23-WAY / GREY 23-WAY / GREEN 23-WAY / BROWN 23-WAY / WHITE 23-WAY / BLUE	BEHIND INSTRUMENT PANEL RH SIDE
DOOR LATCH ASSEMBLY - LH FRONT	FL3 FL9	8-WAY / BLACK 2-WAY / BLACK	LH FRONT DOOR
DOOR LATCH ASSEMBLY - RH FRONT	FR3 FR9	8-WAY / BLACK 2-WAY / BLACK	RH FRONT DOOR
ROOF CONSOLE	RC22 RC30 RC31 RC33 RC34	22-WAY / BLACK 4-WAY / BLACK 2-WAY / BLACK 4-WAY / BLACK 6-WAY / BLACK	ROOF, CENTER FRONT
SLIDING ROOF CONTROL MODULE	RC14	10-WAY / GREY	ROOF CONSOLE

HARNESS IN-LINE CONNECTORS

Connector	Connector Description	Location
CA15	20-WAY / BLACK / DOOR HARNESS TO CABIN HARNESS	DRIVER SIDE A POST
CA16	20-WAY / BLACK / DOOR HARNESS TO CABIN HARNESS	DRIVER SIDE A POST
CA20	20-WAY / BLACK / DOOR HARNESS TO CABIN HARNESS	DRIVER SIDE A POST
CA21	20-WAY / BLACK / DOOR HARNESS TO CABIN HARNESS	DRIVER SIDE A POST
CA36	16-WAY / GREEN / CABIN HARNESS TO ROOF HARNESS	LH LOWER A POST

GROUNDS

Ground	Location
G4	PASSENGER COMPARTMENT / RH LOWER A POST
G5	PASSENGER COMPARTMENT / RH LOWER A POST
G15	PASSENGER COMPARTMENT / LH LOWER A POST

FOR CONTROL MODULE PIN-OUT INFORMATION, UNFOLD PAGE TO LEFT.

The following abbreviations are used to represent values for Control Module Pin-Out data

I	Input	PG	Power Ground	CAN	CAN Network	D	Serial and Encoded Data
O	Output	SS	Sensor / Signal Supply V	SCP	SCP Network	V	Voltage (DC)
B+	Battery Voltage	SG	Sensor / Signal Ground	D2	D2B Network	PWM	Pulse Width Modulated

CAUTION: The information on this data page is furnished to aid the user in understanding circuit operation. THIS INFORMATION SHOULD BE USED FOR REFERENCE ONLY.

NOTE: The characteristics listed are approximately those that can be expected at the control module connector pins with all circuit connections made and all components connected and fitted.

Refer to the front of this book for detailed information and illustrations regarding the location and identification of harnesses, relays, fuses, grounds, control modules and control module pins.

CONTROL MODULE PIN-OUT INFORMATION

Audio Unit

Pin	Description and Characteristic
D2 ID1-1	D2B NETWORK TRANSMIT
D2 ID1-2	D2B NETWORK RECEIVE
PG IP65-1	POWER GROUND: GROUND
B+ IP65-2	IGNITION SWITCHED POWER SUPPLY (I): B+
O IP65-3	LH REAR AUDIO +
O IP65-4	LH REAR AUDIO -
O IP65-5	RH REAR AUDIO +
O IP65-6	RH REAR AUDIO -
I IP65-7	TELEPHONE MUTE SIGNAL
O IP65-8	SECURITY SYSTEM GROUND SENSING: GROUND WHEN AUDIO UNIT INSTALLED
S IP65-9	SCP +
S IP65-10	SCP -
B+ IP65-11	BATTERY POWER SUPPLY: B+
O IP65-13	LH FRONT AUDIO -
O IP65-14	LH FRONT AUDIO +
O IP65-15	RH FRONT AUDIO -
O IP65-16	RH FRONT AUDIO +
I IP65-17	DIMMER CONTROLLED ILLUMINATION: PWM, 80Hz, GROUND = 0% DUTY CYCLE, B+ = 100% DUTY CYCLE
I IP65-18	STEERING WHEEL SWITCHES: STEPPED RESISTANCE
O IP65-19	D2B NETWORK WAKE-UP

NOTE: Refer to the Appendix at the rear of this book for Network Messages.

Fig. 15.1

COMPONENTS

Component	Connector(s)	Connector Description	Location
ANTENNA MODULE	CA117	—	BEHIND LH E POST TRIM
AUDIO CONTROL SWITCHES	SW4	6-WAY / BLACK	STEERING WHEEL
AUDIO UNIT	ID1 IP65 IP106	2-WAY / BLACK 20-WAY / BLACK 2-WAY / COAXIAL	INSTRUMENT PANEL CENTER
CD AUTOCHANGER	CA301 CD2	3-WAY / BLACK 2-WAY / BLACK	TRUNK LH REAR
HEATED REAR WINDOW	ZA1 ZA10	—	REAR WINDOW
SPEAKER – LH FRONT	FL6	2-WAY / WHITE	LH FRONT DOOR CASING
SPEAKER – LH REAR	BL4	2-WAY / WHITE	LH REAR DOOR CASING
SPEAKER – RH FRONT	FR5	2-WAY / WHITE	RH FRONT DOOR CASING
SPEAKER – RH REAR	BR4	2-WAY / WHITE	RH REAR DOOR CASING

HARNESS IN-LINE CONNECTORS

Connector	Connector Description	Location
CA16	20-WAY / BLACK / DOOR HARNESS TO CABIN HARNESS	DRIVER SIDE A POST
CA21	20-WAY / BLACK / DOOR HARNESS TO CABIN HARNESS	DRIVER SIDE A POST
CA25	14-WAY / NATURAL / REAR DOOR HARNESS TO CABIN HARNESS	LH B/C POST
CA30	14-WAY / NATURAL / DOOR LOCK LINK LEAD	RH B/C POST
CA189	2-WAY / COAXIAL / AUDIO SYSTEM ANTENNA	LH LOWER A POST
CA230	16-WAY / BLUE / CABIN HARNESS TO INSTRUMENT PANEL HARNESS	LH LOWER A POST
JB1	42-WAY / BLACK / JUNCTION BOX HARNESS TO ENGINE HARNESS	ADJACENT TO LH SUSPENSION TURRET
JB129	22-WAY / GREY / INSTRUMENT PANEL HARNESS TO JUNCTION BOX HARNESS	LH LOWER A POST

GROUNDS

Ground	Location
G1	TRUNK / LH REAR
G14	ENGINE COMPARTMENT / REARWARD OF POWER DISTRIBUTION FUSE BOX
G37	PASSENGER COMPARTMENT / LH CROSS CAR BEAM

FOR CONTROL MODULE PIN-OUT INFORMATION, UNFOLD PAGE TO LEFT.

The following abbreviations are used to represent values for Control Module Pin-Out data

I	Input	PG	Power Ground	CAN	CAN Network	D	Serial and Encoded Data
O	Output	SS	Sensor / Signal Supply V	SCP	SCP Network	V	Voltage (DC)
B+	Battery Voltage	SG	Sensor / Signal Ground	D2	D2B Network	PWM	Pulse Width Modulated

CAUTION: The information on this data page is furnished to aid the user in understanding circuit operation. THIS INFORMATION SHOULD BE USED FOR REFERENCE ONLY.

NOTE: The characteristics listed are approximately those that can be expected at the control module connector pins with all circuit connections made and all components connected and fitted.

Refer to the front of this book for detailed information and illustrations regarding the location and identification of harnesses, relays, fuses, grounds, control modules and control module pins.

Fig. 15.2

Audio Unit

Pin	Description and Characteristic
D2 ID1-1	D2B NETWORK TRANSMIT
D2 ID1-2	D2B NETWORK RECEIVE
PG IP65-1	POWER GROUND: GROUND
B+ IP65-2	IGNITION SWITCHED POWER SUPPLY (I): B+
O IP65-3	LH REAR AUDIO +
O IP65-4	LH REAR AUDIO -
O IP65-5	RH REAR AUDIO +
O IP65-6	RH REAR AUDIO -
I IP65-7	TELEPHONE MUTE SIGNAL
O IP65-8	SECURITY SYSTEM GROUND SENSING: GROUND WHEN AUDIO UNIT INSTALLED
S IP65-9	SCP +
S IP65-10	SCP -
B+ IP65-11	BATTERY POWER SUPPLY: B+
O IP65-12	AMPLIFIER ENABLE
O IP65-13	LH FRONT AUDIO -
O IP65-14	LH FRONT AUDIO +
O IP65-15	RH FRONT AUDIO -
O IP65-16	RH FRONT AUDIO +
I IP65-17	DIMMER CONTROLLED ILLUMINATION: PWM, 80Hz, GROUND = 0% DUTY CYCLE, B+ = 100% DUTY CYCLE
I IP65-18	STEERING WHEEL SWITCHES: STEPPED RESISTANCE
O IP65-19	D2B NETWORK WAKE-UP

NOTE: Refer to the Appendix at the rear of this book for Network Messages.

COMPONENTS

Component	Connector(s)	Connector Description	Location
ANTENNA MODULE	CA117	—	BEHIND LH E POST TRIM
AUDIO CONTROL SWITCHES	SW4	6-WAY / BLACK	STEERING WHEEL
AUDIO UNIT	ID1 IP65 IP106	2-WAY / BLACK 20-WAY / BLACK 2-WAY / COAXIAL	INSTRUMENT PANEL CENTER
CD AUTOCHANGER	CA301 CD2	3-WAY / BLACK 2-WAY / BLACK	TRUNK LH REAR
HEATED REAR WINDOW	ZA1 ZA10	—	REAR WINDOW
MID BASS SPEAKER – LH FRONT	FL6	2-WAY / WHITE	LH FRONT DOOR CASING
MID BASS SPEAKER – LH REAR	BL4	2-WAY / WHITE	LH REAR DOOR CASING
MID BASS SPEAKER – RH FRONT	FR5	2-WAY / WHITE	RH FRONT DOOR CASING
MID BASS SPEAKER – RH REAR	BR4	2-WAY / WHITE	RH REAR DOOR CASING
SUB WOOFER	CA124	14-WAY / GREY	PARCEL SHELF
TWEETER – LH FRONT	FL8	2-WAY / WHITE	LH FRONT DOOR CASING
TWEETER – LH REAR	BL5	2-WAY / WHITE	LH REAR DOOR CASING
TWEETER – RH FRONT	FR8	2-WAY / WHITE	RH FRONT DOOR CASING
TWEETER – RH REAR	BR8	2-WAY / WHITE	RH REAR DOOR CASING

HARNESS IN-LINE CONNECTORS

Connector	Connector Description	Location
CA16	20-WAY / BLACK / DOOR HARNESS TO CABIN HARNESS	DRIVER SIDE A POST
CA21	20-WAY / BLACK / DOOR HARNESS TO CABIN HARNESS	DRIVER SIDE A POST
CA25	14-WAY / NATURAL / REAR DOOR HARNESS TO CABIN HARNESS	LH B/C POST
CA30	14-WAY / NATURAL / DOOR LOCK LINK LEAD	RH B/C POST
CA189	2-WAY / COAXIAL / AUDIO SYSTEM ANTENNA	LH LOWER A POST
CA230	16-WAY / BLUE / CABIN HARNESS TO INSTRUMENT PANEL HARNESS	LH LOWER A POST
JB1	42-WAY / BLACK / JUNCTION BOX HARNESS TO ENGINE HARNESS	ADJACENT TO LH SUSPENSION TURRET
JB129	22-WAY / GREY / INSTRUMENT PANEL HARNESS TO JUNCTION BOX HARNESS	LH LOWER A POST

GROUNDINGS

Ground	Location
G1	TRUNK / LH REAR
G2	TRUNK / LH REAR
G14	ENGINE COMPARTMENT / REARWARD OF POWER DISTRIBUTION FUSE BOX
G37	PASSENGER COMPARTMENT / LH CROSS CAR BEAM

FOR CONTROL MODULE PIN-OUT INFORMATION, UNFOLD PAGE TO LEFT.

The following abbreviations are used to represent values for Control Module Pin-Out data

I Input	PG Power Ground	CAN CAN Network	D Serial and Encoded Data
O Output	SS Sensor / Signal Supply V	SCP SCP Network	V Voltage (DC)
B+ Battery Voltage	SG Sensor / Signal Ground	D2 D2B Network	PWM Pulse Width Modulated

CAUTION: The information on this data page is furnished to aid the user in understanding circuit operation. THIS INFORMATION SHOULD BE USED FOR REFERENCE ONLY.

NOTE: The characteristics listed are approximately those that can be expected at the control module connector pins with all circuit connections made and all components connected and fitted.

Refer to the front of this book for detailed information and illustrations regarding the location and identification of harnesses, relays, fuses, grounds, control modules and control module pins.

CONTROL MODULE PIN-OUT INFORMATION

Fig. 16.1

Cellular Phone Control Module

Pin	Description and Characteristic
O	PH1-1 PHONE BATTERY CHARGING SUPPLY
O	PH1-3 PHONE ON / OFF (RESPONSE TO INCOMING AUDIO)
O	PH1-4 MUTE COMMAND
—	PH1-7 COMPUTER
—	PH1-8 COMPUTER
PG	PH1-9 POWER GROUND: GROUND
SG	PH1-11 MICROPHONE SHIELD: GROUND
B+	PH1-12 BATTERY POWER SUPPLY: B+
B+	PH1-13 BATTERY POWER SUPPLY: B+
B+	PH1-14 IGNITION SWITCHED POWER SUPPLY (I): B+
I	PH1-15 JaguarNet ASSISTANCE REQUEST
O	PH1-16 JaguarNet ASSISTANCE CALL INDICATOR
I	PH1-17 MICROPHONE +
I	PH1-18 MICROPHONE -
D	PH1-20 TELEPHONE SERIAL COMMUNICATIONS DATA
D	PH1-22 TELEPHONE SERIAL COMMUNICATIONS DATA
I	PH1-23 D2B NETWORK WAKE-UP
—	PH1-24 COMPUTER
I	PH1-25 POWER GROUND: GROUND
I	PH1-26 TELEPHONE LOGIC GROUND: GROUND
I	PH1-29 IGNITION SWITCHED POWER SUPPLY (II): B+
I	PH1-30 AIRBAG DEPLOYED SIGNAL
I	PH1-31 JaguarNet INFORMATION REQUEST
O	PH1-32 JaguarNet INFORMATION CALL INDICATOR
D2	CD3-1 D2B NETWORK RECEIVE
D2	CD3-2 D2B NETWORK TRANSMIT

COMPONENTS

Component	Connector(s)	Connector Description	Location
AUDIO UNIT	ID1 IP65 IP106	2-WAY / BLACK 20-WAY / BLACK 2-WAY / COAXIAL	INSTRUMENT PANEL CENTER
CELLULAR PHONE CONTROL MODULE	CD3 PH1 PH3 PH5	2-WAY / BLACK 32-WAY / BLACK 2-WAY / COAXIAL 2-WAY / COAXIAL	TRUNK LH REAR
HANDESET RECEIVER (ROW)	PP1	—	CENTER CONSOLE
JaguarNet GPS ANTENNA	PH5	2-WAY / COAXIAL	BEHIND LH REAR QUARTER TRIM PANEL
NAVIGATION CONTROL MODULE	CD5 NA1 NA2 NA6 NA7	2-WAY / BLACK 26-WAY NATURAL 12-WAY / BLACK 2-WAY / COAXIAL 20-WAY / BLACK	TRUNK LH REAR
ROOF CONSOLE	RC22 RC30 RC31 RC33 RC34	22-WAY / BLACK 4-WAY / BLACK 2-WAY / BLACK 4-WAY / BLACK 6-WAY / BLACK	ROOF, CENTER FRONT
TELEMATICS DISPLAY	IP70	22-WAY / BLACK	CENTER CONSOLE
TELEPHONE ANTENNA, BUMPER (ROW)	—	—	REAR BUMPER
TELEPHONE ANTENNA, JaguarNet (ROW)	PH13	2-WAY / COAXIAL	PARCEL SHELF

HARNESS IN-LINE CONNECTORS

Connector	Connector Description	Location
CA1	22-WAY / NATURAL / CABIN HARNESS TO INSTRUMENT PANEL HARNESS	LH LOWER A POST
CA35	10-WAY / GREY / CABIN HARNESS TO ROOF HARNESS	RH LOWER A POST
CA36	16-WAY / GREEN / CABIN HARNESS TO ROOF HARNESS	LH LOWER A POST
CA241	22-WAY / GREEN / INSTRUMENT PANEL HARNESS TO CABIN HARNESS	ADJACENT TO CENTRAL JUNCTION FUSE BOX
CA406	3-WAY / GREY / TELEPHONE HARNESS TO CABIN HARNESS	BELOW LH REAR SEAT CUSHION
CA407	16-WAY / GREEN / TELEPHONE HARNESS TO CABIN HARNESS	BELOW LH REAR SEAT CUSHION
CA414	16-WAY / BLUE / TELEPHONE HARNESS TO CABIN HARNESS	BELOW LH REAR SEAT CUSHION
PH11	10-WAY / GREY / CELLULAR TELEPHONE LINK LEAD	LH LOWER A POST

GROUNDS

Ground	Location
G15	PASSENGER COMPARTMENT / LH LOWER A POST
G39	TRUNK / LH REAR

FOR CONTROL MODULE PIN-OUT INFORMATION, UNFOLD PAGE TO LEFT.

The following abbreviations are used to represent values for Control Module Pin-Out data

I	Input	PG	Power Ground	CAN	CAN Network	D	Serial and Encoded Data
O	Output	SS	Sensor / Signal Supply V	SCP	SCP Network	V	Voltage (DC)
B+	Battery Voltage	SG	Sensor / Signal Ground	D2	D2B Network	PWM	Pulse Width Modulated

CAUTION: The information on this data page is furnished to aid the user in understanding circuit operation. THIS INFORMATION SHOULD BE USED FOR REFERENCE ONLY.

NOTE: The characteristics listed are approximately those that can be expected at the control module connector pins with all circuit connections made and all components connected and fitted.

Refer to the front of this book for detailed information and illustrations regarding the location and identification of harnesses, relays, fuses, grounds, control modules and control module pins.

Cellular Phone Control Module

Pin	Description and Characteristic
O	PH1-1 PHONE BATTERY CHARGING SUPPLY
O	PH1-2 HANDS FREE AUDIO TO PHONE
O	PH1-3 PHONE ON / OFF (RESPONSE TO INCOMING AUDIO)
O	PH1-4 MUTE COMMAND
I	PH1-5 MANUAL TEST DATA
I	PH1-6 PHONE BATTERY VOLTAGE
PG	PH1-9 POWER GROUND: GROUND
SG	PH1-10 ANALOG GROUND: GROUND
SG	PH1-11 MICROPHONE SHIELD: GROUND
B+	PH1-12 BATTERY POWER SUPPLY: B+
B+	PH1-13 BATTERY POWER SUPPLY: B+
B+	PH1-14 IGNITION SWITCHED POWER SUPPLY (I): B+
I	PH1-15 JaguarNet ASSISTANCE REQUEST
O	PH1-16 JaguarNet ASSISTANCE CALL INDICATOR
I	PH1-17 MICROPHONE +
I	PH1-18 MICROPHONE -
D	PH1-20 TELEPHONE SERIAL COMMUNICATIONS DATA
D	PH1-21 TELEPHONE SERIAL COMMUNICATIONS DATA
D	PH1-22 TELEPHONE SERIAL COMMUNICATIONS DATA
I	PH1-23 D2B NETWORK WAKE-UP
I	PH1-25 POWER GROUND: GROUND
I	PH1-26 TELEPHONE LOGIC GROUND: GROUND
I	PH1-29 IGNITION SWITCHED POWER SUPPLY (II): B+
I	PH1-30 AIRBAG DEPLOYED SIGNAL
I	PH1-31 JaguarNet INFORMATION REQUEST
O	PH1-32 JaguarNet INFORMATION CALL INDICATOR
D2	CD3-1 D2B NETWORK RECEIVE
D2	CD3-2 D2B NETWORK TRANSMIT

COMPONENTS

Component	Connector(s)	Connector Description	Location
AUDIO UNIT	ID1 IP65 IP106	2-WAY / BLACK 20-WAY / BLACK 2-WAY / COAXIAL	INSTRUMENT PANEL CENTER
CELLULAR PHONE CONTROL MODULE	CD3 PH1 PH3 PH5	2-WAY / BLACK 32-WAY / BLACK 2-WAY / COAXIAL 2-WAY / COAXIAL	TRUNK LH REAR
HANDSET RECEIVER (NAS)	PH9 PH10	— 10-WAY / GREY	LH A POST LH A POST
JaguarNet GPS ANTENNA	PH5	2-WAY / COAXIAL	BEHIND LH REAR QUARTER TRIM PANEL
NAVIGATION CONTROL MODULE	CD5 NA1 NA2 NA6 NA7	2-WAY / BLACK 26-WAY NATURAL 12-WAY / BLACK 2-WAY / COAXIAL 20-WAY / BLACK	TRUNK LH REAR
ROOF CONSOLE	RC22 RC30 RC31 RC33 RC34	22-WAY / BLACK 4-WAY / BLACK 2-WAY / BLACK 4-WAY / BLACK 6-WAY / BLACK	ROOF, CENTER FRONT
TELEMATICS DISPLAY	IP70	22-WAY / BLACK	CENTER CONSOLE
TELEPHONE ANTENNA, BUMPER (NAS)	PH4	2-WAY	REAR BUMPER
TELEPHONE ANTENNA, JaguarNet (NAS)	PH12	2-WAY / COAXIAL	PARCEL SHELF

HARNESS IN-LINE CONNECTORS

Connector	Connector Description	Location
CA1	22-WAY / NATURAL / CABIN HARNESS TO INSTRUMENT PANEL HARNESS	LH LOWER A POST
CA35	10-WAY / GREY / CABIN HARNESS TO ROOF HARNESS	RH LOWER A POST
CA36	16-WAY / GREEN / CABIN HARNESS TO ROOF HARNESS	LH LOWER A POST
CA241	22-WAY / GREEN / INSTRUMENT PANEL HARNESS TO CABIN HARNESS	ADJACENT TO CENTRAL JUNCTION FUSE BOX
CA406	3-WAY / GREY / TELEPHONE HARNESS TO CABIN HARNESS	BELOW LH REAR SEAT CUSHION
CA407	16-WAY / GREEN / TELEPHONE HARNESS TO CABIN HARNESS	BELOW LH REAR SEAT CUSHION
CA414	16-WAY / BLUE / TELEPHONE HARNESS TO CABIN HARNESS	BELOW LH REAR SEAT CUSHION

GROUNDS

Ground	Location
G15	PASSENGER COMPARTMENT / LH LOWER A POST
G39	TRUNK / LH REAR

FOR CONTROL MODULE PIN-OUT INFORMATION, UNFOLD PAGE TO LEFT.

The following abbreviations are used to represent values for Control Module Pin-Out data

I	Input	PG	Power Ground	CAN	CAN Network	D	Serial and Encoded Data
O	Output	SS	Sensor / Signal Supply V	SCP	SCP Network	V	Voltage (DC)
B+	Battery Voltage	SG	Sensor / Signal Ground	D2	D2B Network	PWM	Pulse Width Modulated

CAUTION: The information on this data page is furnished to aid the user in understanding circuit operation. THIS INFORMATION SHOULD BE USED FOR REFERENCE ONLY.

NOTE: The characteristics listed are approximately those that can be expected at the control module connector pins with all circuit connections made and all components connected and fitted.

Refer to the front of this book for detailed information and illustrations regarding the location and identification of harnesses, relays, fuses, grounds, control modules and control module pins.

Cellular Phone Control Module

Pin	Description and Characteristic
O	PH1-1 PHONE BATTERY CHARGING SUPPLY
O	PH1-3 PHONE ON / OFF (RESPONSE TO INCOMING AUDIO)
O	PH1-4 MUTE COMMAND
—	PH1-7 COMPUTER
—	PH1-8 COMPUTER
PG	PH1-9 POWER GROUND: GROUND
SG	PH1-11 MICROPHONE SHIELD: GROUND
B+	PH1-12 BATTERY POWER SUPPLY: B+
B+	PH1-13 BATTERY POWER SUPPLY: B+
B+	PH1-14 IGNITION SWITCHED POWER SUPPLY (II): B+
I	PH1-15 JaguarNet ASSISTANCE REQUEST
O	PH1-16 JaguarNet ASSISTANCE CALL INDICATOR
I	PH1-17 MICROPHONE +
I	PH1-18 MICROPHONE -
D	PH1-20 TELEPHONE SERIAL COMMUNICATIONS DATA
D	PH1-22 TELEPHONE SERIAL COMMUNICATIONS DATA
I	PH1-23 D2B NETWORK WAKE-UP
—	PH1-24 COMPUTER
I	PH1-25 POWER GROUND: GROUND
I	PH1-26 TELEPHONE LOGIC GROUND: GROUND
I	PH1-29 IGNITION SWITCHED POWER SUPPLY (III): B+
I	PH1-30 AIRBAG DEPLOYED SIGNAL
I	PH1-31 JaguarNet INFORMATION REQUEST
O	PH1-32 JaguarNet INFORMATION CALL INDICATOR
D2	CD3-1 D2B NETWORK RECEIVE
D2	CD3-2 D2B NETWORK TRANSMIT

Voice Activation Control Module

Pin	Description and Characteristic
I	PH2-1 MICROPHONE +
SG	PH2-2 MICROPHONE SHIELD
B+	PH2-6 IGNITION SWITCHED POWER SUPPLY (III) (START / RUN STATUS)
B+	PH2-8 IGNITION SWITCHED POWER SUPPLY (I)
PG	PH2-11 POWER GROUND
I	PH2-12 MICROPHONE -
O	PH2-14 D2B NETWORK WAKE UP
B+	PH2-22 BATTERY POWER SUPPLY
D2	CD4-1 D2B NETWORK RECEIVE
D2	CD2-2 D2B NETWORK TRANSMIT

COMPONENTS

Component	Connector(s)	Connector Description	Location
AUDIO CONTROL SWITCHES	SW4	6-WAY / BLACK	STEERING WHEEL
AUDIO UNIT	ID1	2-WAY / BLACK	INSTRUMENT PANEL CENTER
	IP65	20-WAY / BLACK	
	IP106	2-WAY / COAXIAL	
CELLULAR PHONE CONTROL MODULE	CD3	2-WAY / BLACK	TRUNK LH REAR
	PH1	32-WAY / BLACK	
	PH3	2-WAY / COAXIAL	
	PH5	2-WAY / COAXIAL	
HANDSET RECEIVER (ROW)	PP1	—	CENTER CONSOLE
JaguarNet GPS ANTENNA	PH5	2-WAY / COAXIAL	BEHIND LH REAR QUARTER TRIM PANEL
NAVIGATION CONTROL MODULE	CD5	2-WAY / BLACK	TRUNK LH REAR
	NA1	26-WAY NATURAL	
	NA2	12-WAY / BLACK	
	NA6	2-WAY / COAXIAL	
	NA7	20-WAY / BLACK	
ROOF CONSOLE	RC22	22-WAY / BLACK	ROOF, CENTER FRONT
	RC30	4-WAY / BLACK	
	RC31	2-WAY / BLACK	
	RC33	4-WAY / BLACK	
	RC34	6-WAY / BLACK	
TELEMATICS DISPLAY	IP70	22-WAY / BLACK	CENTER CONSOLE
	IP136	2-WAY	
	IP137	2-WAY	
	IP138	2-WAY	
	IP139	2-WAY	
TELEPHONE ANTENNA, BUMPER (ROW)	—	—	REAR BUMPER
TELEPHONE ANTENNA, JaguarNet (ROW)	PH13	2-WAY / COAXIAL	PARCEL SHELF
VOICE ACTIVATION CONTROL MODULE	PH2	22-WAY / GREY	TRUNK LH REAR

HARNESS IN-LINE CONNECTORS

Connector	Connector Description	Location
CA1	22-WAY / NATURAL / CABIN HARNESS TO INSTRUMENT PANEL HARNESS	LH LOWER A POST
CA35	10-WAY / GREY / CABIN HARNESS TO ROOF HARNESS	RH LOWER A POST
CA36	16-WAY / GREEN / CABIN HARNESS TO ROOF HARNESS	LH LOWER A POST
CA241	22-WAY / GREEN / INSTRUMENT PANEL HARNESS TO CABIN HARNESS	ADJACENT TO CENTRAL JUNCTION FUSE BOX
CA406	3-WAY / GREY / TELEPHONE HARNESS TO CABIN HARNESS	BELOW LH REAR SEAT CUSHION
CA407	16-WAY / GREEN / TELEPHONE HARNESS TO CABIN HARNESS	BELOW LH REAR SEAT CUSHION
CA414	16-WAY / BLUE / TELEPHONE HARNESS TO CABIN HARNESS	BELOW LH REAR SEAT CUSHION
JB1	42-WAY / BLACK / JUNCTION BOX HARNESS TO ENGINE HARNESS	ADJACENT TO LH SUSPENSION TURRET
JB129	22-WAY / GREY / INSTRUMENT PANEL HARNESS TO JUNCTION BOX HARNESS	LH LOWER A POST
PH11	10-WAY / GREY / CELLULAR TELEPHONE LINK LEAD	LH LOWER A POST

GROUNDS

Ground	Location
G14	ENGINE COMPARTMENT / REARWARD OF POWER DISTRIBUTION FUSE BOX
G15	PASSENGER COMPARTMENT / LH LOWER A POST
G39	TRUNK / LH REAR

FOR CONTROL MODULE PIN-OUT INFORMATION, UNFOLD PAGE TO LEFT.

The following abbreviations are used to represent values for Control Module Pin-Out data

I	Input	PG	Power Ground	CAN	CAN Network	D	Serial and Encoded Data
O	Output	SS	Sensor / Signal Supply V	SCP	SCP Network	V	Voltage (DC)
B+	Battery Voltage	SG	Sensor / Signal Ground	D2	D2B Network	PWM	Pulse Width Modulated

CAUTION: The information on this data page is furnished to aid the user in understanding circuit operation. THIS INFORMATION SHOULD BE USED FOR REFERENCE ONLY.

NOTE: The characteristics listed are approximately those that can be expected at the control module connector pins with all circuit connections made and all components connected and fitted.

Refer to the front of this book for detailed information and illustrations regarding the location and identification of harnesses, relays, fuses, grounds, control modules and control module pins.

Cellular Phone Control Module

Pin	Description and Characteristic
O	PH1-1 PHONE BATTERY CHARGING SUPPLY
O	PH1-2 HANDS FREE AUDIO TO PHONE
O	PH1-3 PHONE ON / OFF (RESPONSE TO INCOMING AUDIO)
O	PH1-4 MUTE COMMAND
I	PH1-5 MANUAL TEST DATA
I	PH1-6 PHONE BATTERY VOLTAGE
PG	PH1-9 POWER GROUND: GROUND
SG	PH1-10 ANALOG GROUND: GROUND
SG	PH1-11 MICROPHONE SHIELD: GROUND
B+	PH1-12 BATTERY POWER SUPPLY: B+
B+	PH1-13 BATTERY POWER SUPPLY: B+
B+	PH1-14 IGNITION SWITCHED POWER SUPPLY (I): B+
I	PH1-15 JaguarNet ASSISTANCE REQUEST
O	PH1-16 JaguarNet ASSISTANCE CALL INDICATOR
I	PH1-17 MICROPHONE +
I	PH1-18 MICROPHONE -
D	PH1-20 TELEPHONE SERIAL COMMUNICATIONS DATA
D	PH1-21 TELEPHONE SERIAL COMMUNICATIONS DATA
D	PH1-22 TELEPHONE SERIAL COMMUNICATIONS DATA
I	PH1-23 D2B NETWORK WAKE-UP
I	PH1-25 POWER GROUND: GROUND
I	PH1-26 TELEPHONE LOGIC GROUND: GROUND
I	PH1-29 IGNITION SWITCHED POWER SUPPLY (II): B+
I	PH1-30 AIRBAG DEPLOYED SIGNAL
I	PH1-31 JaguarNet INFORMATION REQUEST
O	PH1-32 JaguarNet INFORMATION CALL INDICATOR
D2	CD3-1 D2B NETWORK RECEIVE
D2	CD3-2 D2B NETWORK TRANSMIT

Voice Activation Control Module

Pin	Description and Characteristic
I	PH2-1 MICROPHONE +
SG	PH2-2 MICROPHONE SHIELD
B+	PH2-6 IGNITION SWITCHED POWER SUPPLY (III) (START / RUN STATUS)
B+	PH2-8 IGNITION SWITCHED POWER SUPPLY (I)
PG	PH2-11 POWER GROUND
I	PH2-12 MICROPHONE -
O	PH2-14 D2B NETWORK WAKE UP
B+	PH2-22 BATTERY POWER SUPPLY
D2	CD4-1 D2B NETWORK RECEIVE
D2	CD2-2 D2B NETWORK TRANSMIT

The following abbreviations are used to represent values for Control Module Pin-Out data

I	Input	PG	Power Ground	CAN	CAN Network	D	Serial and Encoded Data
O	Output	SS	Sensor / Signal Supply V	SCP	SCP Network	V	Voltage (DC)
B+	Battery Voltage	SG	Sensor / Signal Ground	D2	D2B Network	PWM	Pulse Width Modulated

CAUTION: The information on this data page is furnished to aid the user in understanding circuit operation. THIS INFORMATION SHOULD BE USED FOR REFERENCE ONLY.

NOTE: The characteristics listed are approximately those that can be expected at the control module connector pins with all circuit connections made and all components connected and fitted.

COMPONENTS

Component	Connector(s)	Connector Description	Location
AUDIO CONTROL SWITCHES	SW4	6-WAY / BLACK	STEERING WHEEL
AUDIO UNIT	ID1	2-WAY / BLACK	INSTRUMENT PANEL CENTER
	IP65	20-WAY / BLACK	
	IP106	2-WAY / COAXIAL	
CELLULAR PHONE CONTROL MODULE	CD3	2-WAY / BLACK	TRUNK LH REAR
	PH1	32-WAY / BLACK	
	PH3	2-WAY / COAXIAL	
	PH5	2-WAY / COAXIAL	
HANDSET RECEIVER (NAS)	PH9	—	LH A POST
	PH10	10-WAY / GREY	LH A POST
JaguarNet GPS ANTENNA	PH5	2-WAY / COAXIAL	BEHIND LH REAR QUARTER TRIM PANEL
NAVIGATION CONTROL MODULE	CD5	2-WAY / BLACK	TRUNK LH REAR
	NA1	26-WAY NATURAL	
	NA2	12-WAY / BLACK	
	NA6	2-WAY / COAXIAL	
	NA7	20-WAY / BLACK	
ROOF CONSOLE	RC22	22-WAY / BLACK	ROOF, CENTER FRONT
	RC30	4-WAY / BLACK	
	RC31	2-WAY / BLACK	
	RC33	4-WAY / BLACK	
	RC34	6-WAY / BLACK	
TELEMATICS DISPLAY	IP70	22-WAY / BLACK	CENTER CONSOLE
	IP136	2-WAY	
	IP137	2-WAY	
	IP138	2-WAY	
	IP139	2-WAY	
TELEPHONE ANTENNA, BUMPER (NAS)	PH4	2-WAY	REAR BUMPER
TELEPHONE ANTENNA, JaguarNet (NAS)	PH12	2-WAY / COAXIAL	PARCEL SHELF
VOICE ACTIVATION CONTROL MODULE	PH2	22-WAY / GREY	TRUNK LH REAR

HARNESS IN-LINE CONNECTORS

Connector	Connector Description	Location
CA1	22-WAY / NATURAL / CABIN HARNESS TO INSTRUMENT PANEL HARNESS	LH LOWER A POST
CA35	10-WAY / GREY / CABIN HARNESS TO ROOF HARNESS	RH LOWER A POST
CA36	16-WAY / GREEN / CABIN HARNESS TO ROOF HARNESS	LH LOWER A POST
CA241	22-WAY / GREEN / INSTRUMENT PANEL HARNESS TO CABIN HARNESS	ADJACENT TO CENTRAL JUNCTION FUSE BOX
CA406	3-WAY / GREY / TELEPHONE HARNESS TO CABIN HARNESS	BELOW LH REAR SEAT CUSHION
CA407	16-WAY / GREEN / TELEPHONE HARNESS TO CABIN HARNESS	BELOW LH REAR SEAT CUSHION
CA414	16-WAY / BLUE / TELEPHONE HARNESS TO CABIN HARNESS	BELOW LH REAR SEAT CUSHION

GROUND

Ground	Location
G15	PASSENGER COMPARTMENT / LH LOWER A POST
G39	TRUNK / LH REAR

FOR CONTROL MODULE PIN-OUT INFORMATION, UNFOLD PAGE TO LEFT.

Refer to the front of this book for detailed information and illustrations regarding the location and identification of harnesses, relays, fuses, grounds, control modules and control module pins.

Voice Activation Control Module

Pin	Description and Characteristic
I PH2-1	MICROPHONE +
SG PH2-2	MICROPHONE SHIELD
B+ PH2-6	IGNITION SWITCHED POWER SUPPLY (II) (START / RUN STATUS)
B+ PH2-8	IGNITION SWITCHED POWER SUPPLY (I)
PG PH2-11	POWER GROUND
I PH2-12	MICROPHONE -
O PH2-14	D2B NETWORK WAKE UP
B+ PH2-22	BATTERY POWER SUPPLY
D2 CD4-1	D2B NETWORK RECEIVE
D2 CD2-2	D2B NETWORK TRANSMIT

COMPONENTS

Component	Connector(s)	Connector Description	Location
AUDIO CONTROL SWITCHES	SW4	6-WAY / BLACK	STEERING WHEEL
AUDIO UNIT	ID1 IP65 IP106	2-WAY / BLACK 20-WAY / BLACK 2-WAY / COAXIAL	INSTRUMENT PANEL CENTER
ROOF CONSOLE	RC22 RC30 RC31 RC33 RC34	22-WAY / BLACK 4-WAY / BLACK 2-WAY / BLACK 4-WAY / BLACK 6-WAY / BLACK	ROOF, CENTER FRONT
VOICE ACTIVATION CONTROL MODULE	PH2	22-WAY / GREY	TRUNK LH REAR

HARNESS IN-LINE CONNECTORS

Connector	Connector Description	Location
CA35	10-WAY / GREY / CABIN HARNESS TO ROOF HARNESS	RH LOWER A POST
CA406	3-WAY / GREY / TELEPHONE HARNESS TO CABIN HARNESS	BELOW LH REAR SEAT CUSHION
JB1	42-WAY / BLACK / JUNCTION BOX HARNESS TO ENGINE HARNESS	ADJACENT TO LH SUSPENSION TURRET
JB129	22-WAY / GREY / INSTRUMENT PANEL HARNESS TO JUNCTION BOX HARNESS	LH LOWER A POST

GROUNDS

Ground	Location
G1	TRUNK / LH REAR
G14	ENGINE COMPARTMENT / REARWARD OF POWER DISTRIBUTION FUSE BOX

FOR CONTROL MODULE PIN-OUT INFORMATION, UNFOLD PAGE TO LEFT.

The following abbreviations are used to represent values for Control Module Pin-Out data

I	Input	PG	Power Ground	CAN	CAN Network	D	Serial and Encoded Data
O	Output	SS	Sensor / Signal Supply V	SCP	SCP Network	V	Voltage (DC)
B+	Battery Voltage	SG	Sensor / Signal Ground	D2	D2B Network	PWM	Pulse Width Modulated

CAUTION: The information on this data page is furnished to aid the user in understanding circuit operation. THIS INFORMATION SHOULD BE USED FOR REFERENCE ONLY.

NOTE: The characteristics listed are approximately those that can be expected at the control module connector pins with all circuit connections made and all components connected and fitted.

Refer to the front of this book for detailed information and illustrations regarding the location and identification of harnesses, relays, fuses, grounds, control modules and control module pins.

Fig. 16.6**COMPONENTS**

Component	Connector(s)	Connector Description	Location
NAVIGATION CONTROL MODULE	CD5 NA1 NA2 NA6 NA7	2-WAY / BLACK 26-WAY NATURAL 12-WAY / BLACK 2-WAY / COAXIAL 20-WAY / BLACK	TRUNK LH REAR
NAVIGATION GPS ANTENNA	NA12	2-WAY / COAXIAL	BELOW PARCEL SHELF, LH SIDE
TELEMATICS DISPLAY	IP70 IP136 IP137 IP138 IP139	22-WAY / BLACK 2-WAY 2-WAY 2-WAY 2-WAY	CENTER CONSOLE
TRAFFIC MASTER CONTROL MODULE	NA15	5-WAY / GREEN	TRUNK LH REAR

HARNESS IN-LINE CONNECTORS

Connector	Connector Description	Location
NA24	16-WAY / GREEN / NAVIGATION HARNESS TO INSTRUMENT PANEL HARNESS	BELOW INSTRUMENT PANEL LH SIDE

GROUNDS

Ground	Location
G37	PASSENGER COMPARTMENT / LH CROSS CAR BEAM
G40	TRUNK / LH REAR

Refer to the front of this book for detailed information and illustrations regarding the location and identification of harnesses, relays, fuses, grounds, control modules and control module pins.

Fig. 16.7**COMPONENTS**

Component	Connector(s)	Connector Description	Location
NAVIGATION CONTROL MODULE	CD5	2-WAY / BLACK	TRUNK LH REAR
	NA1	26-WAY NATURAL	
	NA2	12-WAY / BLACK	
	NA6	2-WAY / COAXIAL	
	NA7	20-WAY / BLACK	
NAVIGATION GPS ANTENNA	NA12	2-WAY / COAXIAL	BELOW PARCEL SHELF, LH SIDE
ROOF CONSOLE	RC22	22-WAY / BLACK	ROOF, CENTER FRONT
	RC30	4-WAY / BLACK	
	RC31	2-WAY / BLACK	
	RC33	4-WAY / BLACK	
	RC34	6-WAY / BLACK	
TELEMATICS DISPLAY	IP70	22-WAY / BLACK	CENTER CONSOLE
	IP136	2-WAY	
	IP137	2-WAY	
	IP138	2-WAY	
	IP139	2-WAY	
TELEVISION ANTENNA AND AMPLIFIER 1	NA20	2-WAY	TELEVISION ANTENNA
TELEVISION ANTENNA AND AMPLIFIER 2	NA21	2-WAY	TELEVISION ANTENNA
TELEVISION ANTENNA AND AMPLIFIER 3	NA22	2-WAY	TELEVISION ANTENNA
TELEVISION ANTENNA AND AMPLIFIER 4	NA23	2-WAY	TELEVISION ANTENNA
VEHICLE INFORMATION ANTENNA AND AMPLIFIER	NA11	2-WAY	BEHIND RH E POST
VEHICLE INFORMATION CONTROL MODULE	NA9	10-WAY / NATURAL	TRUNK LH REAR
VEHICLE INFORMATION SENSOR	CA222	2-WAY	TOP OF INSTRUMENT PANEL LH SIDE

HARNESS IN-LINE CONNECTORS

Connector	Connector Description	Location
CA35	10-WAY / GREY / CABIN HARNESS TO ROOF HARNESS	RH LOWER A POST
CA406	3-WAY / GREY / TELEPHONE HARNESS TO CABIN HARNESS	BELOW LH REAR SEAT CUSHION
NA24	16-WAY / GREEN / NAVIGATION HARNESS TO INSTRUMENT PANEL HARNESS	BELOW INSTRUMENT PANEL LH SIDE
NA25	8-WAY / COAXIAL / INSTRUMENT PANEL HARNESS TO NAVIGATION HARNESS	BELOW CENTRAL JUNCTION FUSE BOX

GROUNDS

Ground	Location
G37	PASSENGER COMPARTMENT / LH CROSS CAR BEAM
G40	TRUNK / LH REAR

Refer to the front of this book for detailed information and illustrations regarding the location and identification of harnesses, relays, fuses, grounds, control modules and control module pins.

Fig. 17.1**COMPONENTS**

Component	Connector(s)	Connector Description	Location
AIRBAG DEACTIVATED INDICATOR LAMP – PASSENGER	IP140	3-WAY / BLACK	PASSENGER AIRBAG COVER
CURTAIN AIRBAG IGNITER – DRIVER	CA144	2-WAY / BLACK	DRIVER SIDE E POST
CURTAIN AIRBAG IGNITER – PASSENGER	CA145	2-WAY / BLACK	PASSENGER SIDE E POST
DUAL AIRBAG IGNITER – DRIVER	SW1 SW2	2-WAY / BLACK 2-WAY / BLACK	STEERING WHEEL
DUAL AIRBAG IGNITER – PASSENGER	IP36 IP37	2-WAY / BROWN 2-WAY / BLACK	INSTRUMENT PANEL PASSENGER SIDE
FRONT IMPACT SENSOR	JB93	2-WAY / BLACK	ADJACENT TO HOOD CATCH
SEAT BELT PRETENSIONER IGNITER – DRIVER	CA65	18-WAY / BLACK	DRIVER SIDE B/C POST
SEAT BELT PRETENSIONER IGNITER – PASSENGER	CA70	18-WAY / BLACK	PASSENGER SIDE B/C POST
SEAT BELT SWITCH – DRIVER	CA65	18-WAY / BLACK	DRIVER SEAT BELT
SEAT BELT SWITCH – PASSENGER	CA70	18-WAY / BLACK	PASSENGER SEAT BELT
SEAT POSITION SWITCH – DRIVER	CA65	18-WAY / BLACK	DRIVER SEAT TRACK
SEAT WEIGHT PRESSURE SENSOR – PASSENGER	WS18	3-WAY	UNDER PASSENGER SEAT
SEAT WEIGHT SENSING CONTROL MODULE – PASSENGER	WS17	12-WAY	UNDER PASSENGER SEAT
SIDE AIRBAG IGNITER – DRIVER	AL1	2-WAY / BLACK	DRIVER SEAT BACK
SIDE AIRBAG IGNITER – PASSENGER	AD1	2-WAY / BLACK	INSTRUMENT PANEL PASSENGER SIDE
SIDE IMPACT SENSOR – DRIVER	CA215	2-WAY / BLACK	DRIVER SIDE LOWER B/C POST
SIDE IMPACT SENSOR – DRIVER REAR	CA140	2-WAY / BLACK	ADJACENT TO DRIVER SIDE REAR LOWER SAFETY BELT ANCHOR
SIDE IMPACT SENSOR – PASSENGER	CA216	2-WAY / BLACK	DRIVER SIDE LOWER B/C POST
SIDE IMPACT SENSOR – PASSENGER REAR	CA131	2-WAY / BLACK	ADJACENT TO PASSENGER SIDE REAR LOWER SAFETY BELT ANCHOR

HARNES IN-LINE CONNECTORS

Connector	Connector Description	Location
CA10	22-WAY / GREY / ENGINE HARNES TO CABIN HARNES	BELOW THE GLOVEBOX
CA70	18-WAY / BLACK / CABIN HARNES TO SEAT HARNES	BELOW LH FRONT SEAT

GROUNDS

Ground	Location
G4	PASSENGER COMPARTMENT / RH LOWER A POST
G15	PASSENGER COMPARTMENT / LH LOWER A POST
G37	PASSENGER COMPARTMENT / LH CROSS CAR BEAM

Refer to the front of this book for detailed information and illustrations regarding the location and identification of harnesses, relays, fuses, grounds, control modules and control module pins.

CONTROL MODULE PIN-OUT INFORMATION

Control Module

Pin	Description and Characteristic
B+	RB7-1 IGNITION SWITCHED POWER SUPPLY: B+
PG	RB7-3 POWER GROUND: GROUND
D	RB7-5 SERIAL DATA LINK
I	RB7-8 TRAILER CONNECTED STATUS: GROUND = TRAILER CONNECTED
I	RB7-9 REVERSE LAMPS STATUS: B+ = REVERSE LAMPS ON
D	RB7-10 LH CENTER SENSOR SIGNAL DATA
D	RB7-11 LH SENSOR SIGNAL DATA
O	RB7-14 PARKING AID SOUNDER +
O	RB7-15 SENSOR POWER SUPPLY: B+
O	RB7-16 SENSOR GROUND: GROUND
O	RB7-17 PARKING AID SOUNDER
D	RB7-23 RH CENTER SENSOR SIGNAL DATA
D	RB7-24 RH SENSOR SIGNAL DATA

Fig. 18.1

COMPONENTS

Component	Connector(s)	Connector Description	Location
PARKING AID CONTROL MODULE	RB7	26-WAY / YELLOW	SPARE WHEEL WELL
PARKING AID SENSOR – LH	RB1	3-WAY / BLACK	REAR BUMPER
PARKING AID SENSOR – LH CENTER	RB2	3-WAY / BLACK	REAR BUMPER
PARKING AID SENSOR – RH	RB4	3-WAY / BLACK	REAR BUMPER
PARKING AID SENSOR – RH CENTER	RB3	3-WAY / BLACK	REAR BUMPER
PARKING AID SOUNDER	CA136	2-WAY / WHITE	PARCEL SHELF

HARNESS IN-LINE CONNECTORS

Connector	Connector Description	Location
CA129	12-WAY / GREY / CABIN HARNESS TO REAR BUMPER HARNESS	SPARE WHEEL WELL

GROUNDS

Ground	Location
G2	TRUNK / LH REAR

FOR CONTROL MODULE PIN-OUT INFORMATION, UNFOLD PAGE TO LEFT.

The following abbreviations are used to represent values for Control Module Pin-Out data

I	Input	PG	Power Ground	CAN	CAN Network	D	Serial and Encoded Data
O	Output	SS	Sensor / Signal Supply V	SCP	SCP Network	V	Voltage (DC)
B+	Battery Voltage	SG	Sensor / Signal Ground	D2	D2B Network	PWM	Pulse Width Modulated

CAUTION: The information on this data page is furnished to aid the user in understanding circuit operation. THIS INFORMATION SHOULD BE USED FOR REFERENCE ONLY.

NOTE: The characteristics listed are approximately those that can be expected at the control module connector pins with all circuit connections made and all components connected and fitted.

Refer to the front of this book for detailed information and illustrations regarding the location and identification of harnesses, relays, fuses, grounds, control modules and control module pins.

Fig. 19.1

General Electronic Control Module

Pin	Description and Characteristic
PG	CA86-5 POWER GROUND: GROUND
O	IP5-14 HORN RELAY DRIVE : TO ACTIVATE, GEEM SWITCHES CIRCUIT TO GROUND
I	IP6-20 STEERING WHEEL HORN SWITCH: GROUND WHEN SELECTED
B+	JB172-1 BATTERY POWER SUPPLY (LOCKING): B+

COMPONENTS

Component	Connector(s)	Connector Description	Location
CABIN ACCESSORY CONNECTOR	IP24	3-WAY / BLACK	BEHIND GLOVE BOX
CIGAR LIGHTER	IP42	2-WAY / ORANGE	ASH TRAY
GENERAL ELECTRONIC CONTROL MODULE	CA86 CA87 IP5 IP6 JB172	23-WAY / GREY 23-WAY / GREEN 23-WAY / BROWN 23-WAY / WHITE 23-WAY / BLUE	BEHIND INSTRUMENT PANEL RH SIDE
HORN RELAY	—	—	POWER DISTRIBUTION FUSE BOX R3
HORN SWITCH	SW6	2-WAY / BLACK	STEERING WHEEL
HORNS	JB87	2-WAY / BLACK	ADJACENT TO BATTERY
POWER DISTRIBUTION FUSE BOX	—	—	ENGINE COMPARTMENT LH SIDE
ROOF CONSOLE	RC22 RC30 RC31 RC33 RC34	22-WAY / BLACK 4-WAY / BLACK 2-WAY / BLACK 4-WAY / BLACK 6-WAY / BLACK	ROOF, CENTER FRONT
TRUNK ACCESSORY CONNECTOR	CA146	3-WAY / BLACK	TRUNK LH REAR

HARNES IN-LINE CONNECTORS

Connector	Connector Description	Location
CA36	16-WAY / GREEN / CABIN HARNESS TO ROOF HARNESS	LH LOWER A POST
JB129	22-WAY / GREY / INSTRUMENT PANEL HARNESS TO JUNCTION BOX HARNESS	LH LOWER A POST

GROUNDS

Ground	Location
G1	TRUNK / LH REAR
G4	PASSENGER COMPARTMENT / RH LOWER A POST
G5	PASSENGER COMPARTMENT / RH LOWER A POST
G11	ENGINE COMPARTMENT / UNDER LH HEADLAMP ASSEMBLY
G15	PASSENGER COMPARTMENT / LH LOWER A POST
G36	PASSENGER COMPARTMENT / RH CROSS CAR BEAM
G37	PASSENGER COMPARTMENT / LH CROSS CAR BEAM

FOR CONTROL MODULE PIN-OUT INFORMATION, UNFOLD PAGE TO LEFT.

The following abbreviations are used to represent values for Control Module Pin-Out data

I	Input	PG	Power Ground	CAN	CAN Network	D	Serial and Encoded Data
O	Output	SS	Sensor / Signal Supply V	SCP	SCP Network	V	Voltage (DC)
B+	Battery Voltage	SG	Sensor / Signal Ground	D2	D2B Network	PWM	Pulse Width Modulated

CAUTION: The information on this data page is furnished to aid the user in understanding circuit operation. THIS INFORMATION SHOULD BE USED FOR REFERENCE ONLY.

NOTE: The characteristics listed are approximately those that can be expected at the control module connector pins with all circuit connections made and all components connected and fitted.

Refer to the front of this book for detailed information and illustrations regarding the location and identification of harnesses, relays, fuses, grounds, control modules and control module pins.

Fig. 20.1**COMPONENTS**

Component	Connector(s)	Connector Description	Location
ANTI-LOCK BRAKING SYSTEM CONTROL MODULE	JB45	42-WAY / BROWN	ENGINE COMPARTMENT RH SIDE
ANTI-LOCK BRAKING / TRACTION CONTROL CONTROL MODULE	JB197	42-WAY / BROWN	ENGINE COMPARTMENT RH SIDE
AIR CONDITIONING CONTROL MODULE (MANUAL, PANEL)	AC1 IP39 IP101 IP135	26-WAY / YELLOW 6-WAY / GREY 26-WAY / YELLOW 2-WAY / GREY	BEHIND CLIMATE CONTROL PANEL
AIR CONDITIONING CONTROL MODULE (AUTOMATIC, PANEL)	AC1 IP101	26-WAY / YELLOW 26-WAY / YELLOW	BEHIND CLIMATE CONTROL PANEL
AIR CONDITIONING CONTROL MODULE (REMOTE)	AC1 IP101	26-WAY / YELLOW 26-WAY / YELLOW	RH SIDE OF AIR DISTRIBUTION UNIT
DATA LINK CONNECTOR	IP22	16-WAY / BLACK	BELOW STEERING COLUMN
ENGINE CONTROL MODULE (2.0L)	EN65	104-WAY / BLACK	ENGINE COMPARTMENT, FRONT BULKHEAD RH SIDE
ENGINE CONTROL MODULE (2.5L & 3.0L)	EN16	134-WAY / BLACK	ENGINE COMPARTMENT, FRONT BULKHEAD RH SIDE
HEADLAMP LEVELING CONTROL MODULE	IP130	26-WAY / YELLOW	BEHIND INSTRUMENT PANEL LH SIDE
INSTRUMENT CLUSTER	IP10 IP11	26-WAY / YELLOW 26-WAY / YELLOW	INSTRUMENT PANEL
J GATE ASSEMBLY	IP14	16-WAY / GREEN	CENTER CONSOLE
STEERING ANGLE SENSOR	IP19	4-WAY / BLACK	STEERING COLUMN
TRANSMISSION CONTROL MODULE	JB131	37-WAY / BLUE	LOWER LH A POST
YAW RATE SENSOR	IP20	4-WAY / BLACK	BEHIND CENTER CONSOLE

HARNESS IN-LINE CONNECTORS

Connector	Connector Description	Location
JB1	42-WAY / BLACK / JUNCTION BOX HARNESS TO ENGINE HARNESS	ADJACENT TO LH SUSPENSION TURRET
JB130	22-WAY / GREEN / JUNCTION BOX HARNESS TO INSTRUMENT PANEL HARNESS	ADJACENT TO CENTRAL JUNCTION FUSE BOX

GROUNDS

Ground	Location
G36	PASSENGER COMPARTMENT / RH CROSS CAR BEAM
G37	PASSENGER COMPARTMENT / LH CROSS CAR BEAM

Refer to the front of this book for detailed information and illustrations regarding the location and identification of harnesses, relays, fuses, grounds, control modules and control module pins.

Fig. 20.2**COMPONENTS**

Component	Connector(s)	Connector Description	Location
AUDIO UNIT	ID1	2-WAY / BLACK	INSTRUMENT PANEL CENTER
	IP65	20-WAY / BLACK	
	IP106	2-WAY / COAXIAL	
DATA LINK CONNECTOR	IP22	16-WAY / BLACK	BELOW STEERING COLUMN
ENGINE CONTROL MODULE (2.0L)	EN65	104-WAY / BLACK	ENGINE COMPARTMENT, FRONT BULKHEAD RH SIDE
ENGINE CONTROL MODULE (2.5L & 3.0L)	EN16	134-WAY / BLACK	ENGINE COMPARTMENT, FRONT BULKHEAD RH SIDE
GENERAL ELECTRONIC CONTROL MODULE	CA86	23-WAY / GREY	BEHIND INSTRUMENT PANEL RH SIDE
	CA87	23-WAY / GREEN	
	IP5	23-WAY / BROWN	
	IP6	23-WAY / WHITE	
	JB172	23-WAY / BLUE	
	IP130	26-WAY / YELLOW	
HEADLAMP LEVELING CONTROL MODULE	IP10	26-WAY / YELLOW	BEHIND INSTRUMENT PANEL LH SIDE
INSTRUMENT CLUSTER	IP11	26-WAY / YELLOW	INSTRUMENT PANEL
	CD5	2-WAY / BLACK	
	NA1	26-WAY NATURAL	
NAVIGATION CONTROL MODULE	NA2	12-WAY / BLACK	TRUNK LH REAR
	NA6	2-WAY / COAXIAL	
	NA7	20-WAY / BLACK	
	RB7	26-WAY / YELLOW	
PARKING AID CONTROL MODULE	CA165	40-WAY / BLACK	SPARE WHEEL WELL
RESTRAINTS CONTROL MODULE	IP74	24-WAY / BLACK	UNDER CENTER CONSOLE
	RC22	22-WAY / BLACK	
ROOF CONSOLE	RC30	4-WAY / BLACK	ROOF, CENTER FRONT
	RC31	2-WAY / BLACK	
	RC33	4-WAY / BLACK	
	RC34	6-WAY / BLACK	

HARNESS IN-LINE CONNECTORS

Connector	Connector Description	Location
CA36	16-WAY / GREEN / CABIN HARNESS TO ROOF HARNESS	LH LOWER A POST
CA129	12-WAY / GREY / CABIN HARNESS TO REAR BUMPER HARNESS	SPARE WHEEL WELL
CA230	16-WAY / BLUE / CABIN HARNESS TO INSTRUMENT PANEL HARNESS	LH LOWER A POST
CA241	22-WAY / GREEN / INSTRUMENT PANEL HARNESS TO CABIN HARNESS	ADJACENT TO CENTRAL JUNCTION FUSE BOX
CA414	16-WAY / BLUE / TELEPHONE HARNESS TO CABIN HARNESS	BELOW LH REAR SEAT CUSHION
JB1	42-WAY / BLACK / JUNCTION BOX HARNESS TO ENGINE HARNESS	ADJACENT TO LH SUSPENSION TURRET
JB130	22-WAY / GREEN / JUNCTION BOX HARNESS TO INSTRUMENT PANEL HARNESS	ADJACENT TO CENTRAL JUNCTION FUSE BOX

GROUND

Ground	Location
G36	PASSENGER COMPARTMENT / RH CROSS CAR BEAM
G37	PASSENGER COMPARTMENT / LH CROSS CAR BEAM

Refer to the front of this book for detailed information and illustrations regarding the location and identification of harnesses, relays, fuses, grounds, control modules and control module pins.

Fig. 20.3**COMPONENTS**

Component	Connector(s)	Connector Description	Location
AUDIO UNIT	ID1 IP65 IP106	2-WAY / BLACK 20-WAY / BLACK 2-WAY / COAXIAL	INSTRUMENT PANEL CENTER
CD AUTOCHANGER	CA301 CD2	3-WAY / BLACK 2-WAY / BLACK	TRUNK LH REAR
CELLULAR PHONE CONTROL MODULE	CD3 PH1 PH3 PH5	2-WAY / BLACK 32-WAY / BLACK 2-WAY / COAXIAL 2-WAY / COAXIAL	TRUNK LH REAR
NAVIGATION CONTROL MODULE	CD5 NA1 NA2 NA6 NA7	2-WAY / BLACK 26-WAY NATURAL 12-WAY / BLACK 2-WAY / COAXIAL 20-WAY / BLACK	TRUNK LH REAR
VOICE ACTIVATION CONTROL MODULE	PH2	22-WAY / GREY	TRUNK LH REAR

HARNESS IN-LINE CONNECTORS

Connector	Connector Description	Location
CA241	22-WAY / GREEN / INSTRUMENT PANEL HARNESS TO CABIN HARNESS	ADJACENT TO CENTRAL JUNCTION FUSE BOX
CA407	16-WAY / GREEN / TELEPHONE HARNESS TO CABIN HARNESS	BELOW LH REAR SEAT CUSHION
CA414	16-WAY / BLUE / TELEPHONE HARNESS TO CABIN HARNESS	BELOW LH REAR SEAT CUSHION
CD1	2-WAY / BLACK / FIBER OPTIC CONNECTOR	LH LOWER A POST
CD6	2-WAY / BLACK / FIBER OPTIC CONNECTOR	TRUNK LH REAR

Refer to the front of this book for detailed information and illustrations regarding the location and identification of harnesses, relays, fuses, grounds, control modules and control module pins.

Fig. 20.4**COMPONENTS**

Component	Connector(s)	Connector Description	Location
AUDIO UNIT	ID1 IP65 IP106	2-WAY / BLACK 20-WAY / BLACK 2-WAY / COAXIAL	INSTRUMENT PANEL CENTER
CD AUTOCHANGER	CA301 CD2	3-WAY / BLACK 2-WAY / BLACK	TRUNK LH REAR
CELLULAR PHONE CONTROL MODULE	CD3 PH1 PH3 PH5	2-WAY / BLACK 32-WAY / BLACK 2-WAY / COAXIAL 2-WAY / COAXIAL	TRUNK LH REAR
NAVIGATION CONTROL MODULE	CD5 NA1 NA2 NA6 NA7	2-WAY / BLACK 26-WAY NATURAL 12-WAY / BLACK 2-WAY / COAXIAL 20-WAY / BLACK	TRUNK LH REAR
VOICE ACTIVATION CONTROL MODULE	PH2	22-WAY / GREY	TRUNK LH REAR

HARNESS IN-LINE CONNECTORS

Connector	Connector Description	Location
CD1	2-WAY / BLACK / FIBER OPTIC CONNECTOR	LH LOWER A POST
CD6	2-WAY / BLACK / FIBER OPTIC CONNECTOR	TRUNK LH REAR

Refer to the front of this book for detailed information and illustrations regarding the location and identification of harnesses, relays, fuses, grounds, control modules and control module pins.

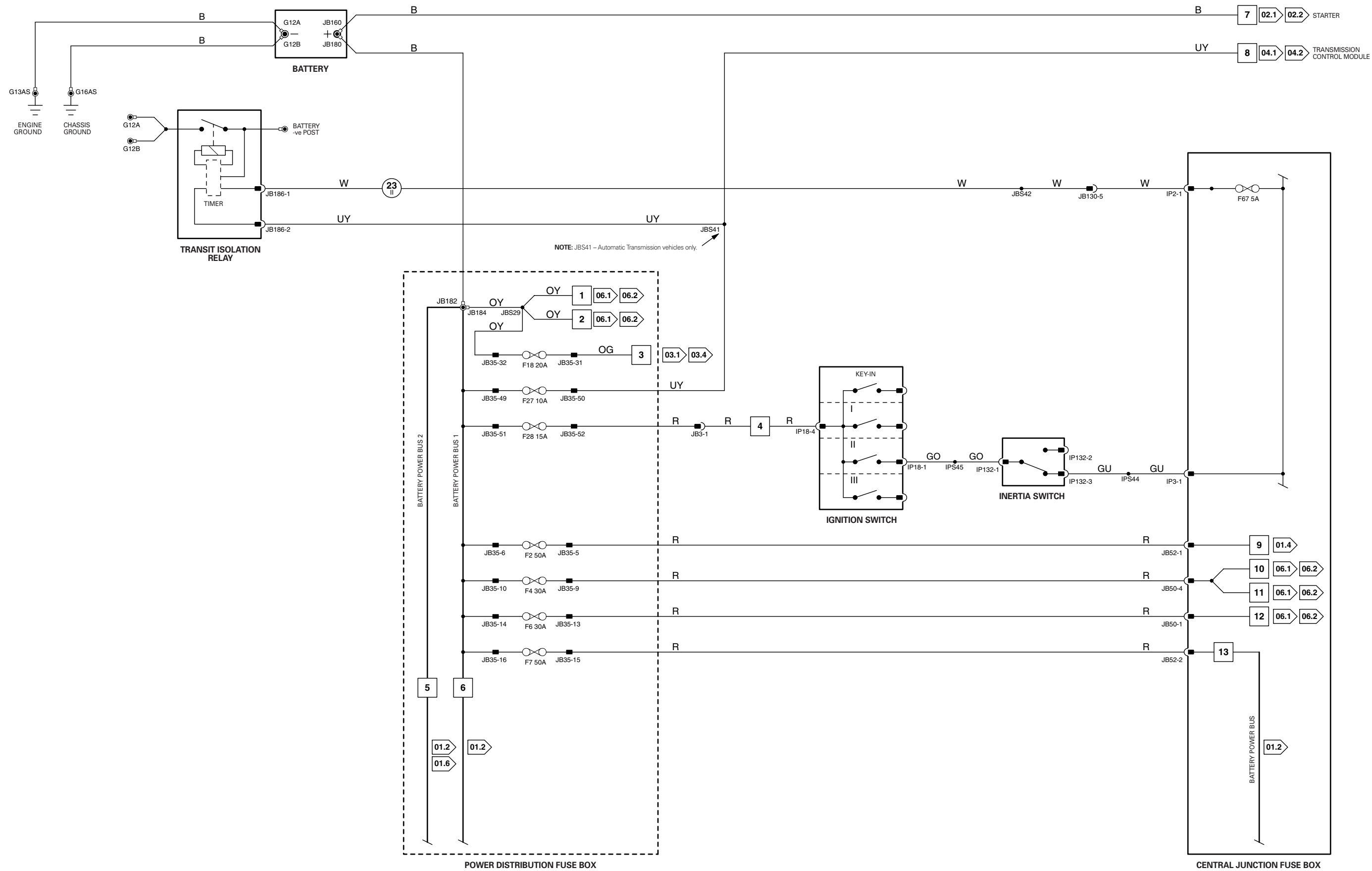

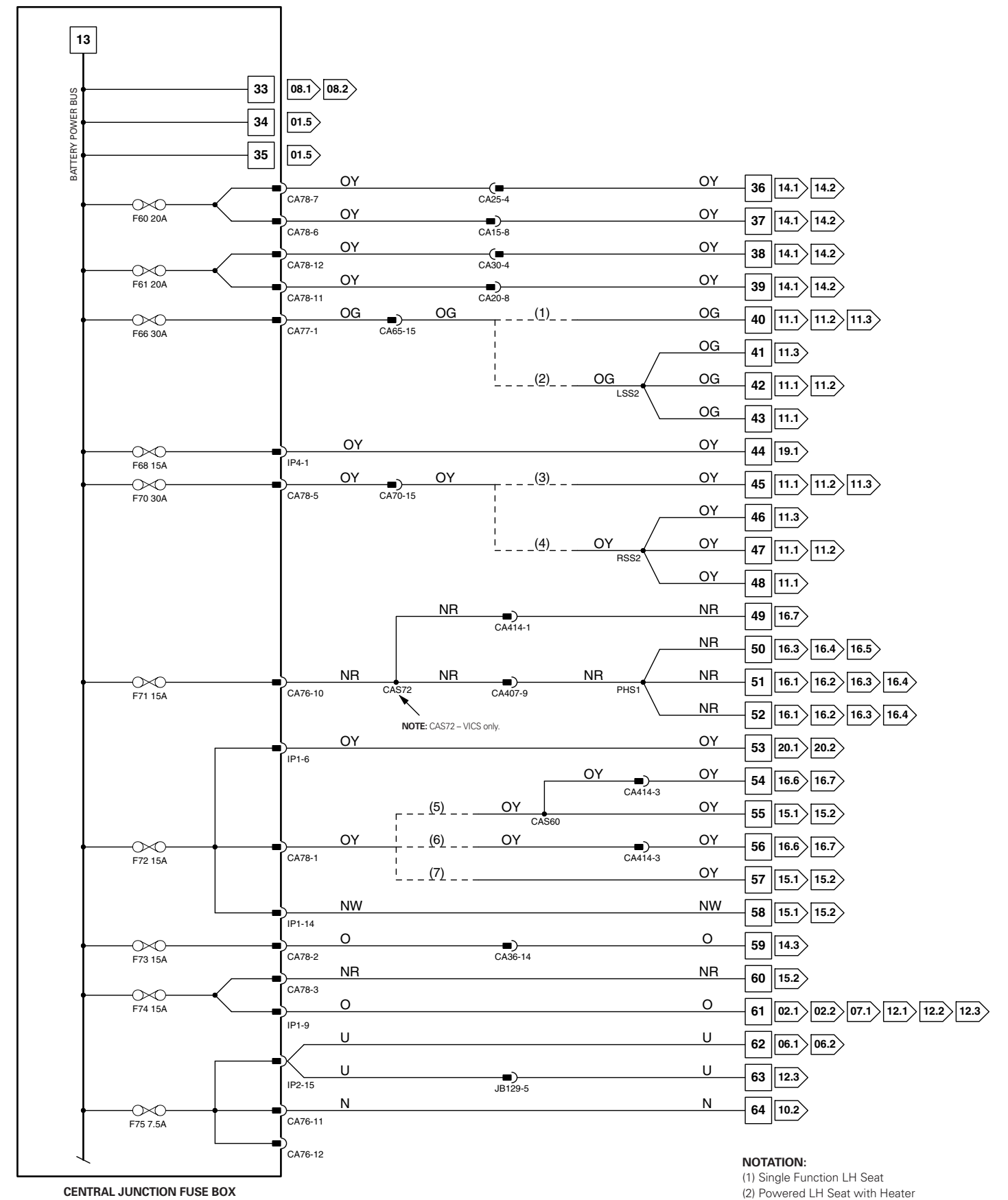
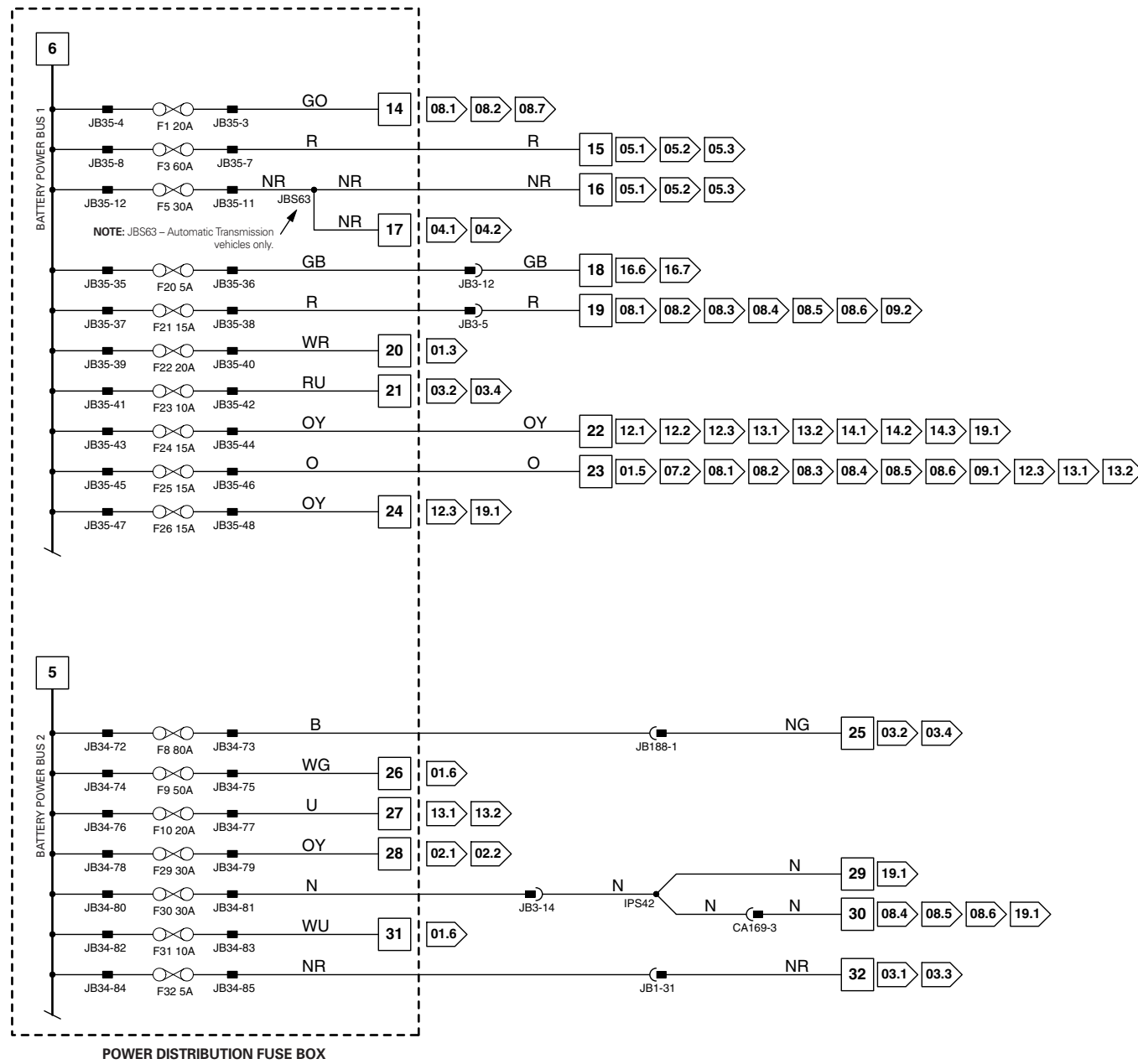

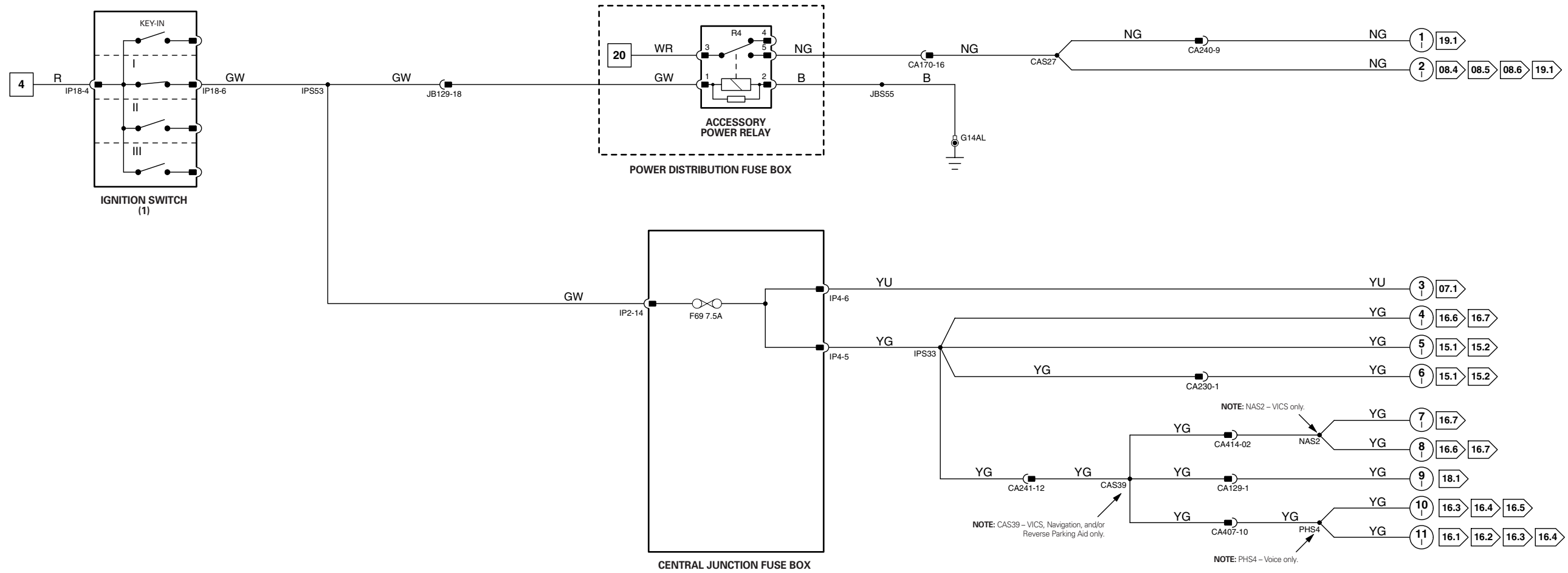

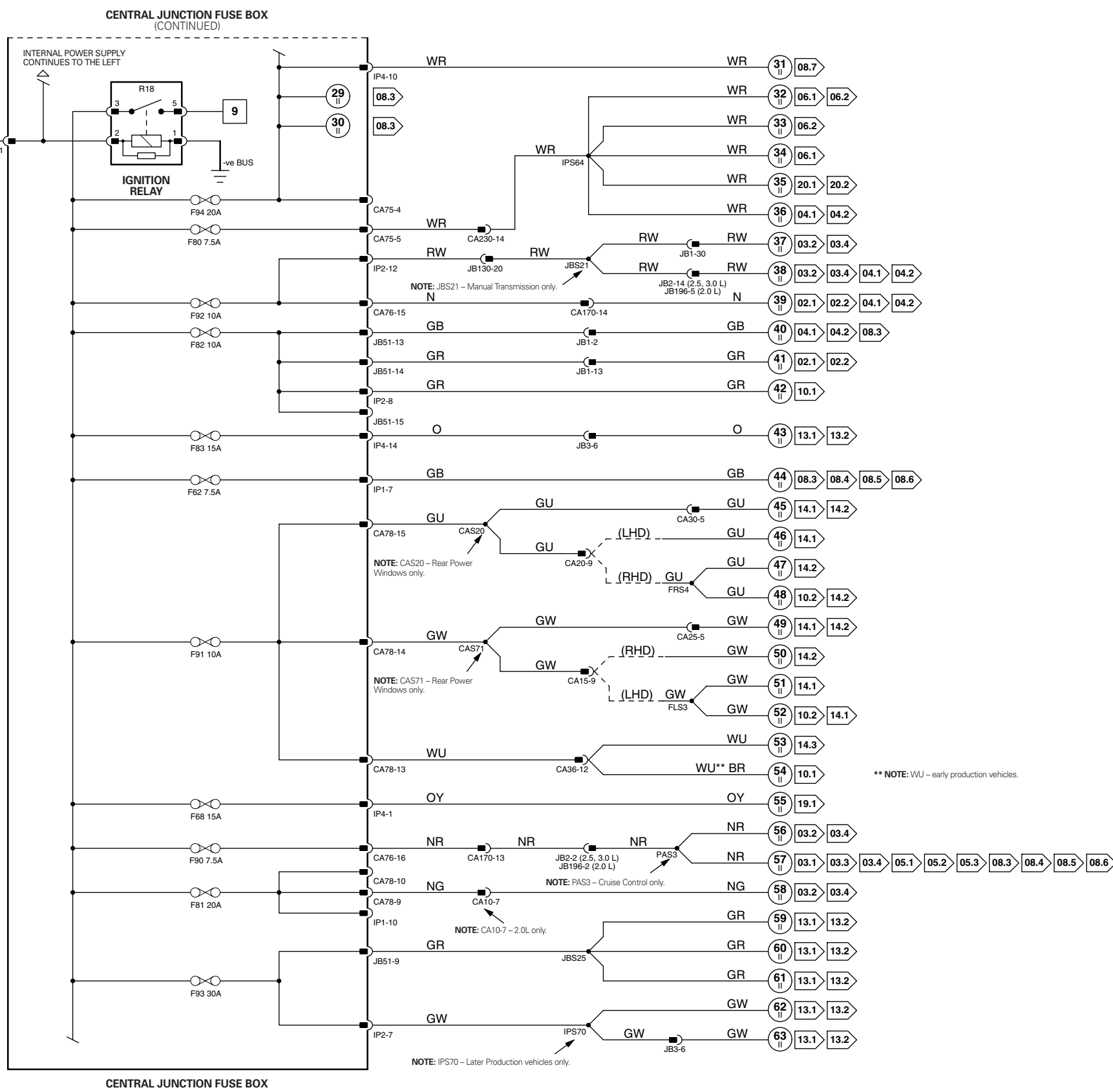
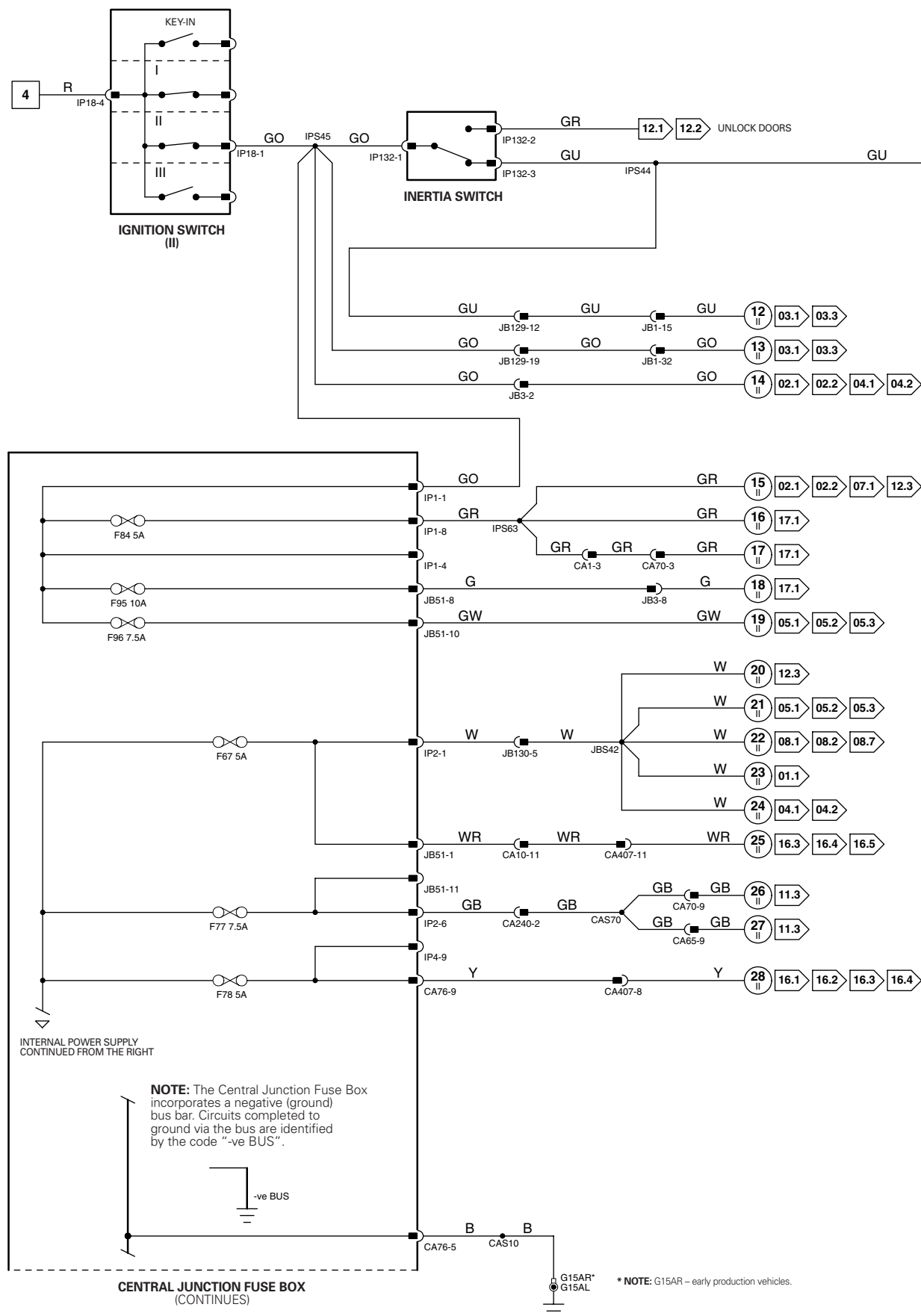

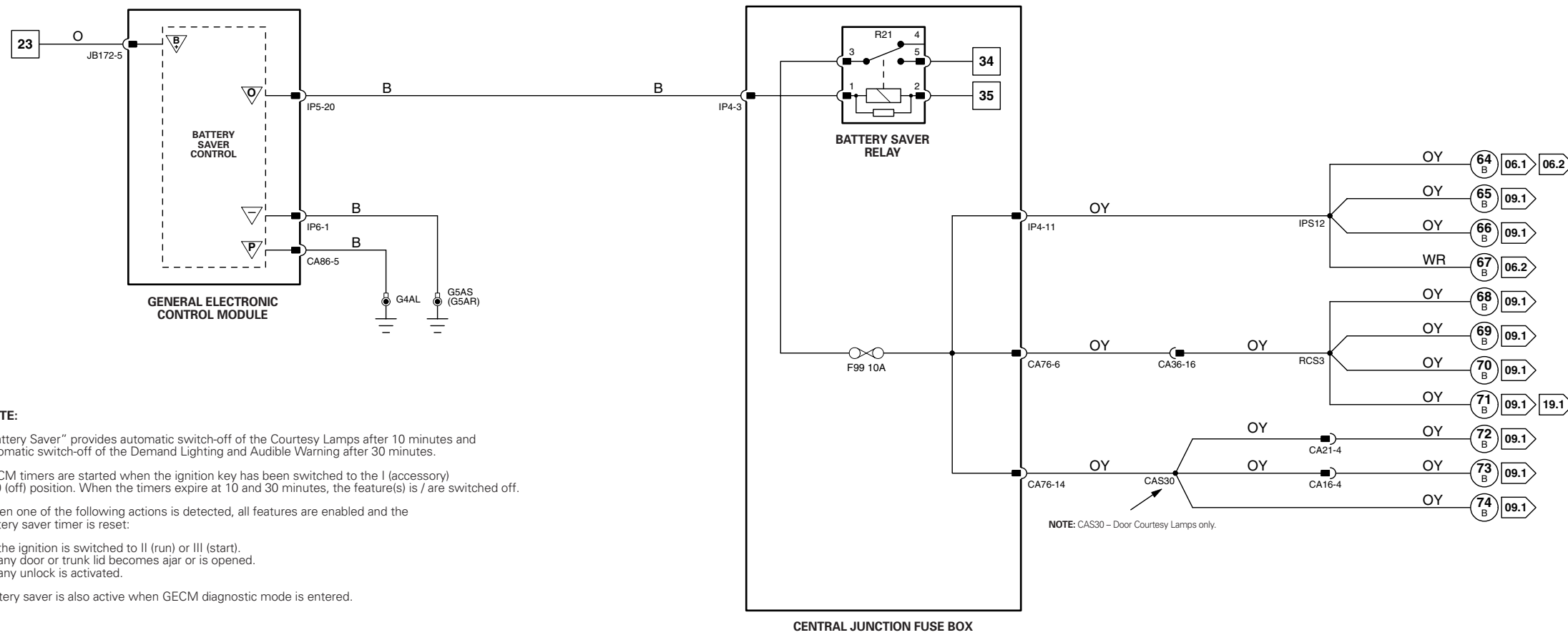

NOTE:

“Battery Saver” provides automatic switch-off of the Courtesy Lamps after 10 minutes and automatic switch-off of the Demand Lighting and Audible Warning after 30 minutes.

GECM timers are started when the ignition key has been switched to the I (accessory) or 0 (off) position. When the timers expire at 10 and 30 minutes, the feature(s) is / are switched off.

When one of the following actions is detected, all features are enabled and the battery saver timer is reset:

- the ignition is switched to II (run) or III (start).
- any door or trunk lid becomes ajar or is opened.
- any unlock is activated.

Battery saver is also active when GECM diagnostic mode is entered.

NOTE: CAS30 – Door Courtesy Lamps only.

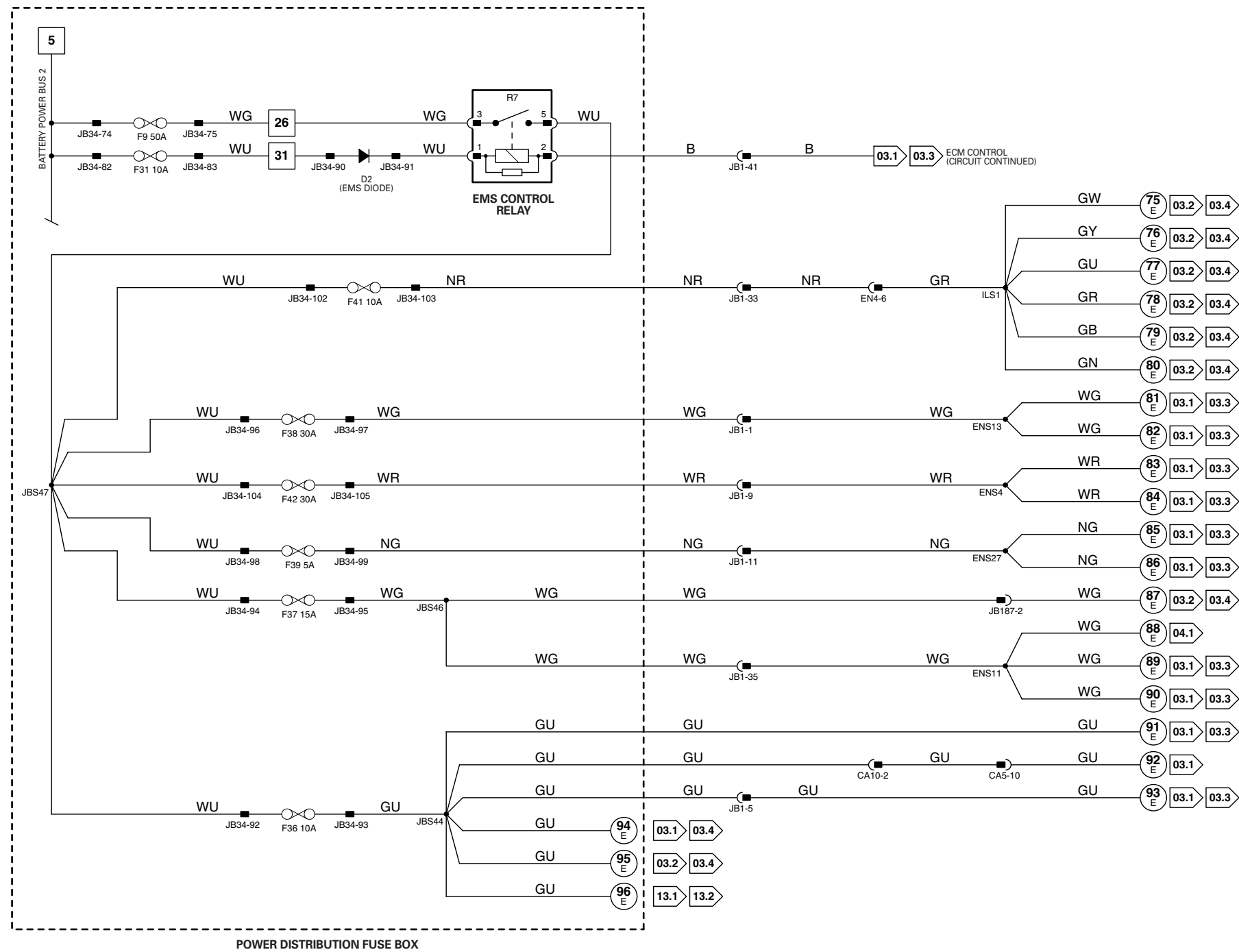

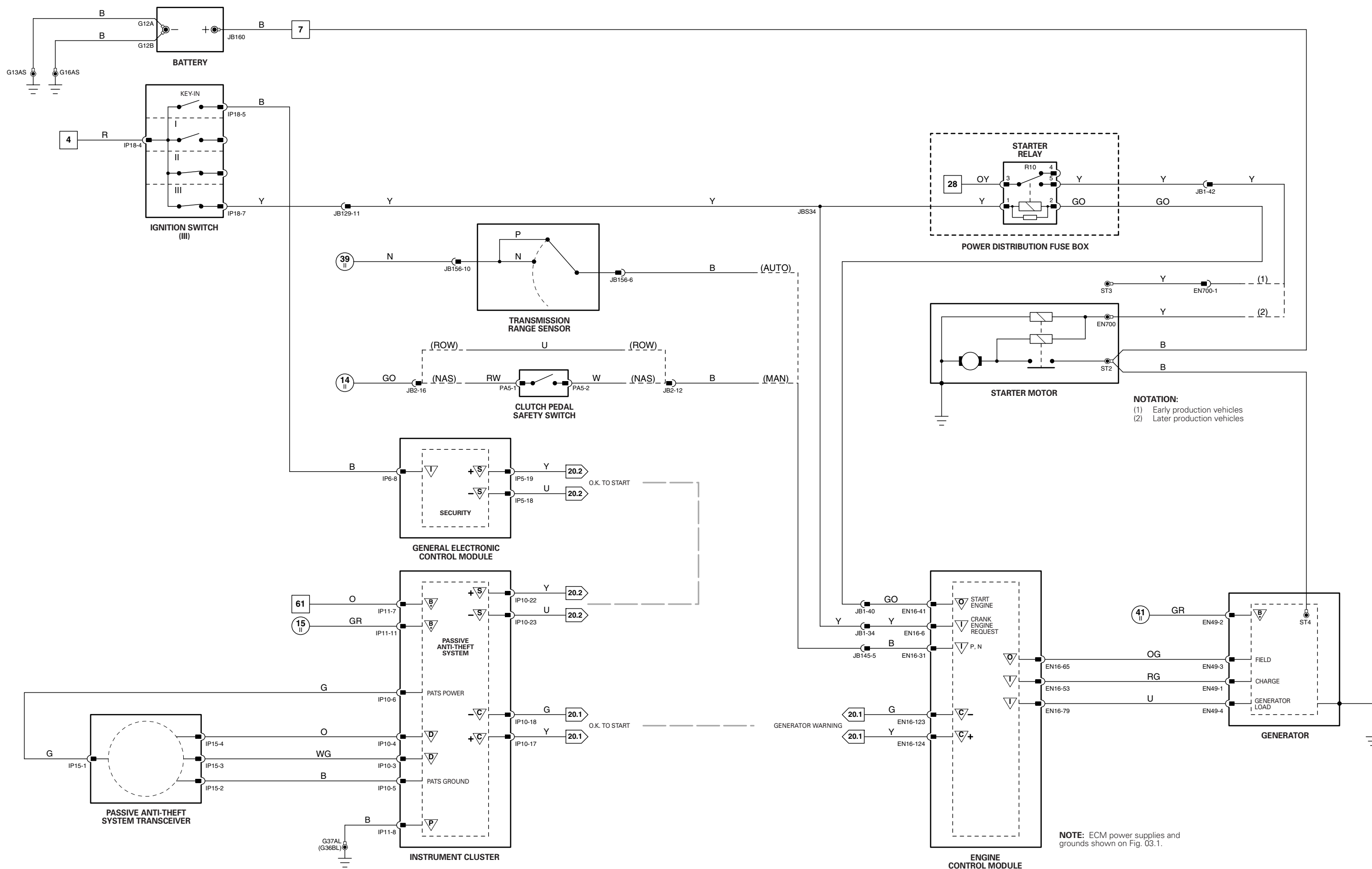

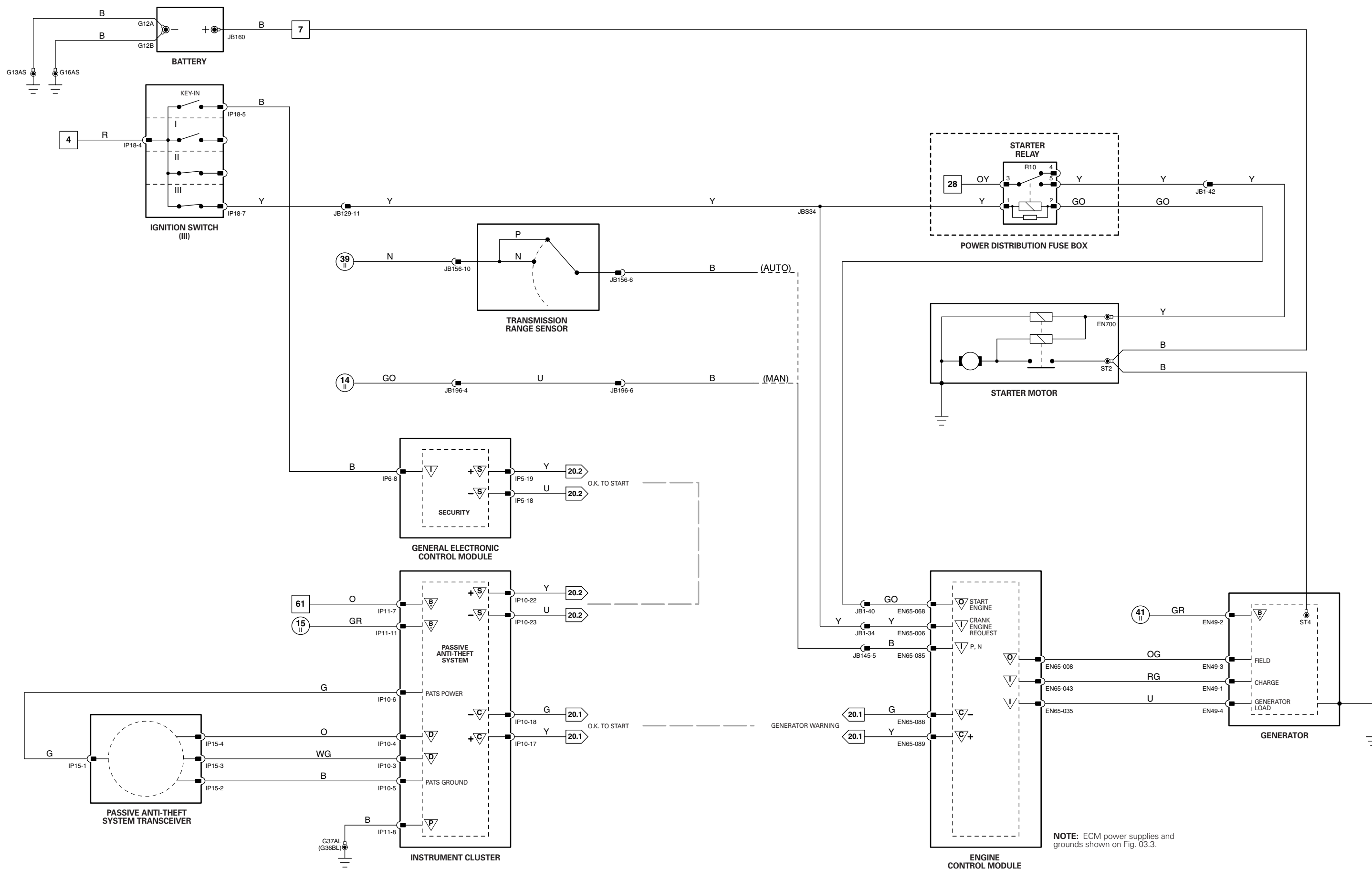

NOTE: ECM power supplies and grounds shown on Fig. 03.3.

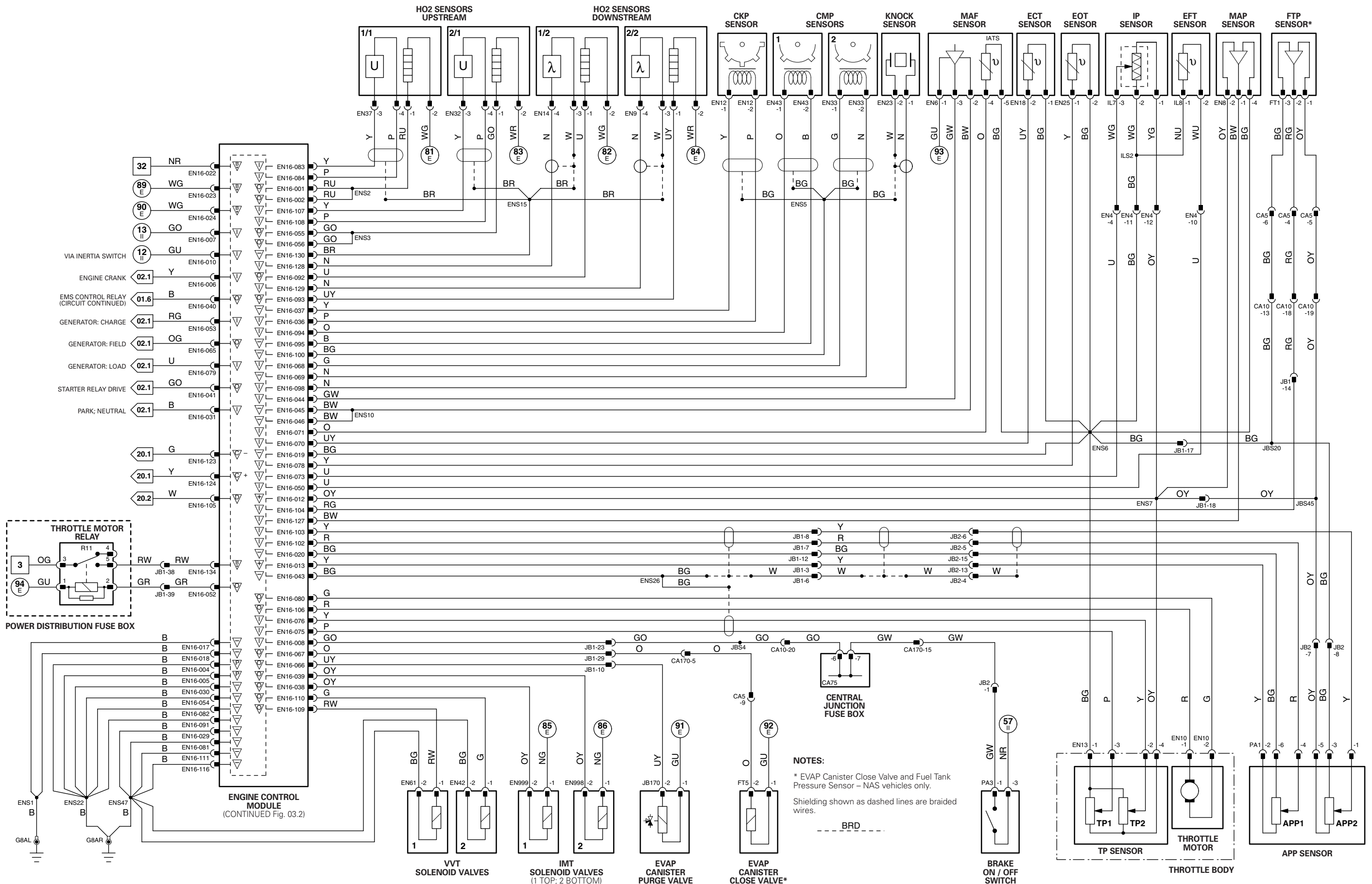

NOTES:
 * EVAP Canister Close Valve and Fuel Tank Pressure Sensor – NAS vehicles only.
 Shielding shown as dashed lines are braided wires.
 --- BRD ---

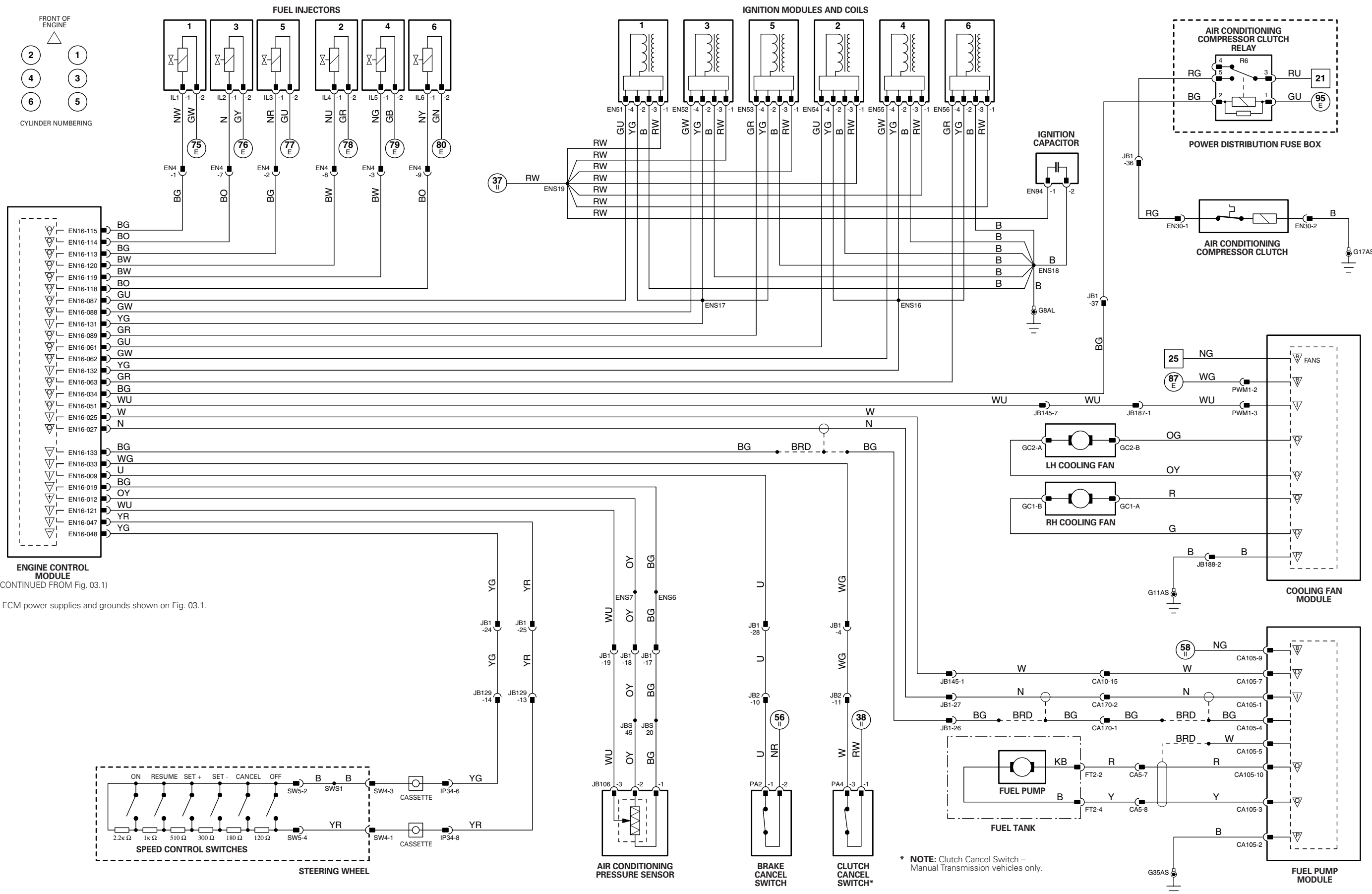

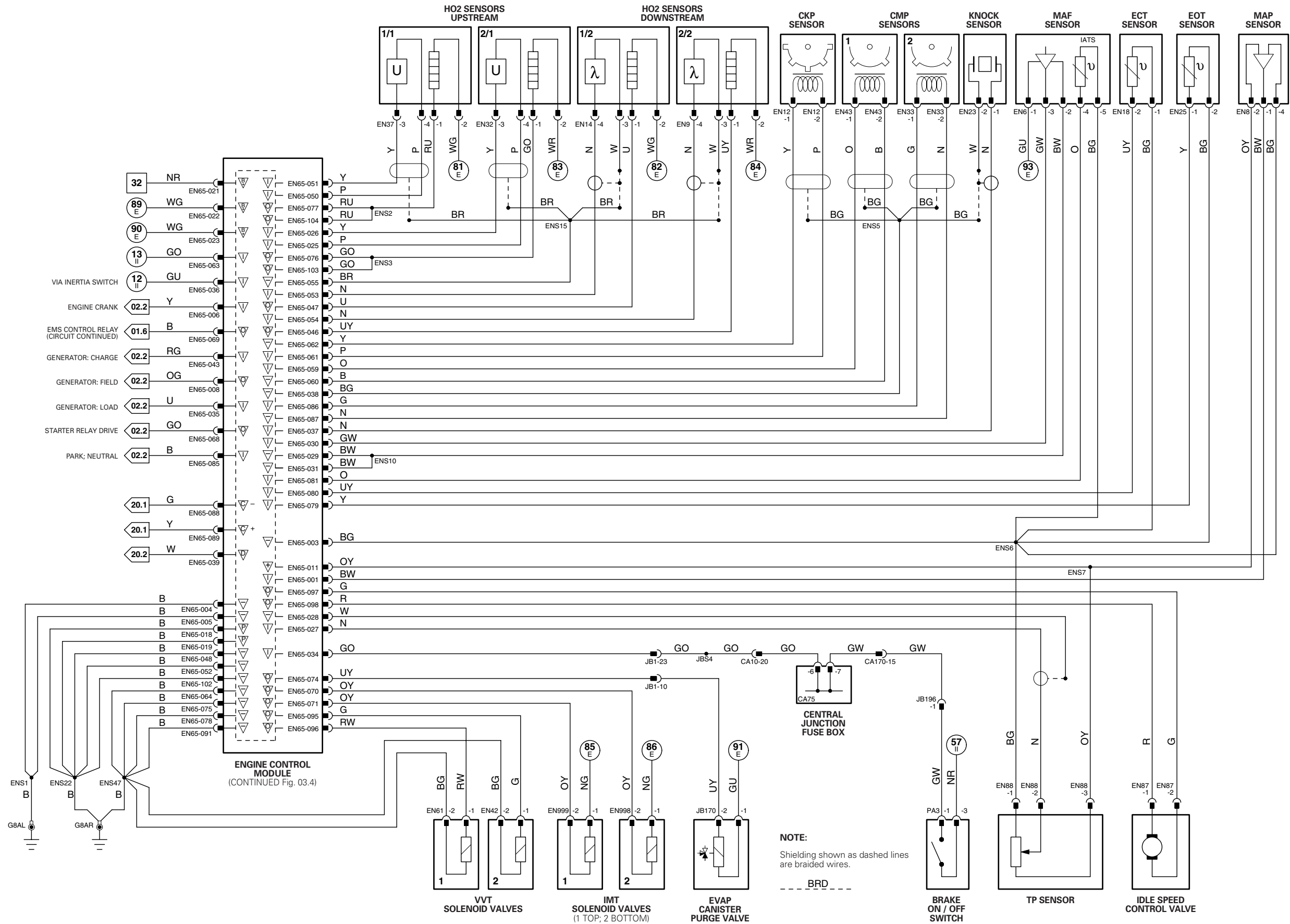

NOTE:
Shielding shown as dashed lines are braided wires.
--- BRD ---

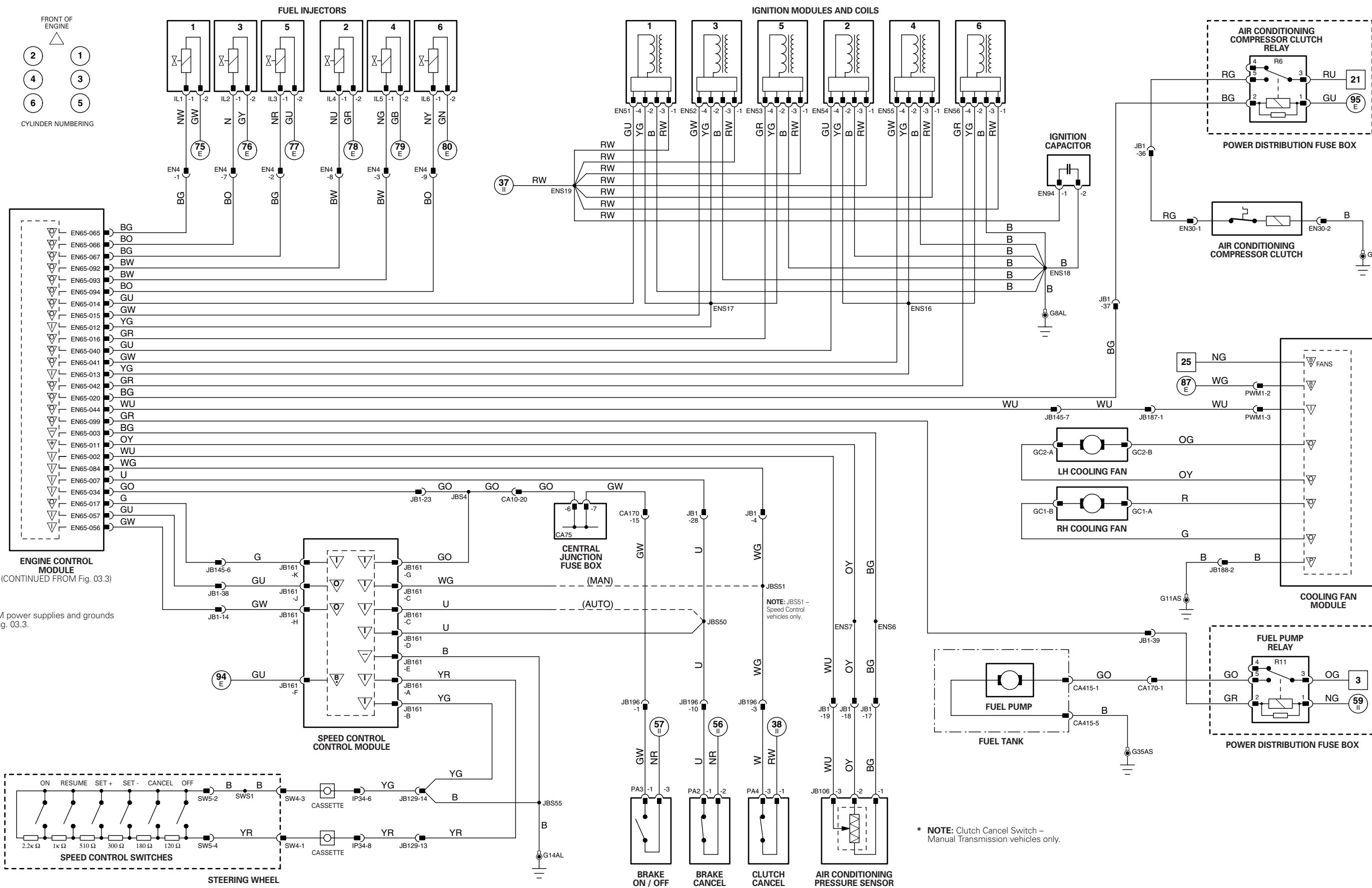

NOTE: ECM power supplies and grounds shown on Fig. 03.3.

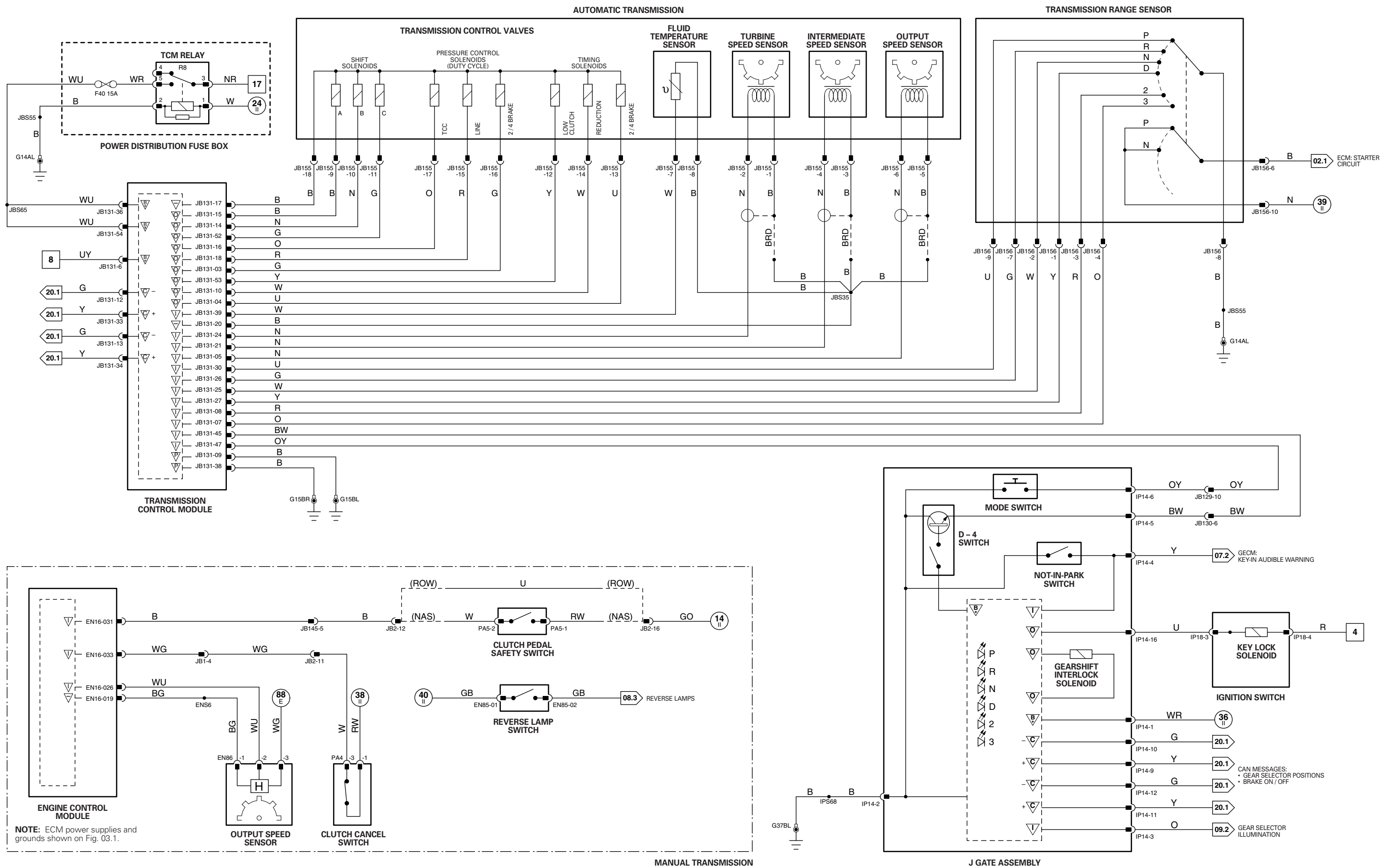

1 → 13 Fig. 01.1

14 → 64 Fig. 01.2

1 → 11 Fig. 01.3

12 → 63 Fig. 01.4

64 → 74 Fig. 01.5

75 → 96 Fig. 01.6

Input

Output

Battery Voltage

Power Ground

Sensor/Signal Supply V

Sensor/Signal Ground

CAN

D2B Network

SCP

Serial and Encoded Data

VARIANT: 2.5L & 3.0L Vehicles
VIN RANGE: Early Production Vehicles
DATE OF ISSUE: December 2001



AUTOMATIC TRANSMISSION (VIN C72268 → D15361)

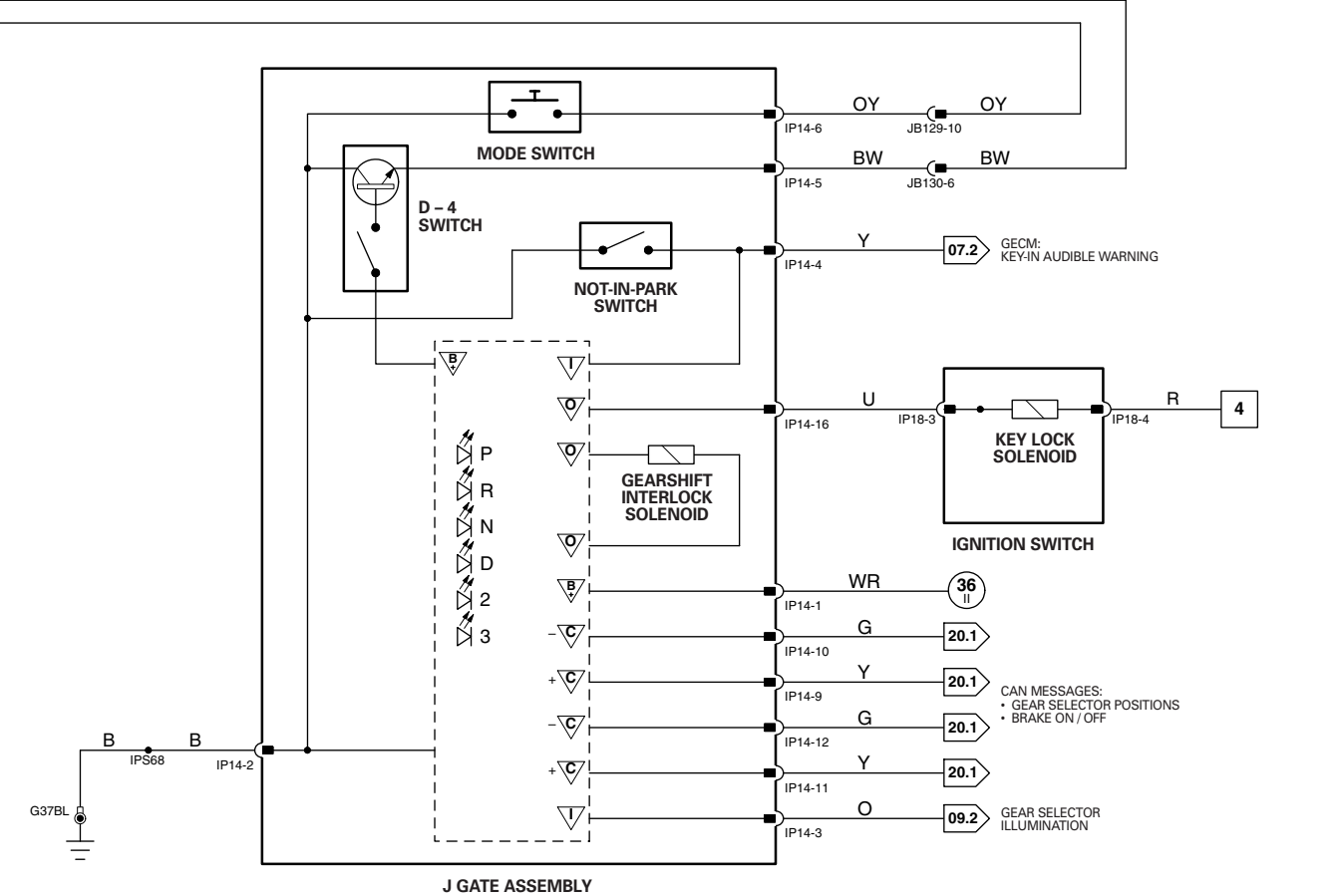
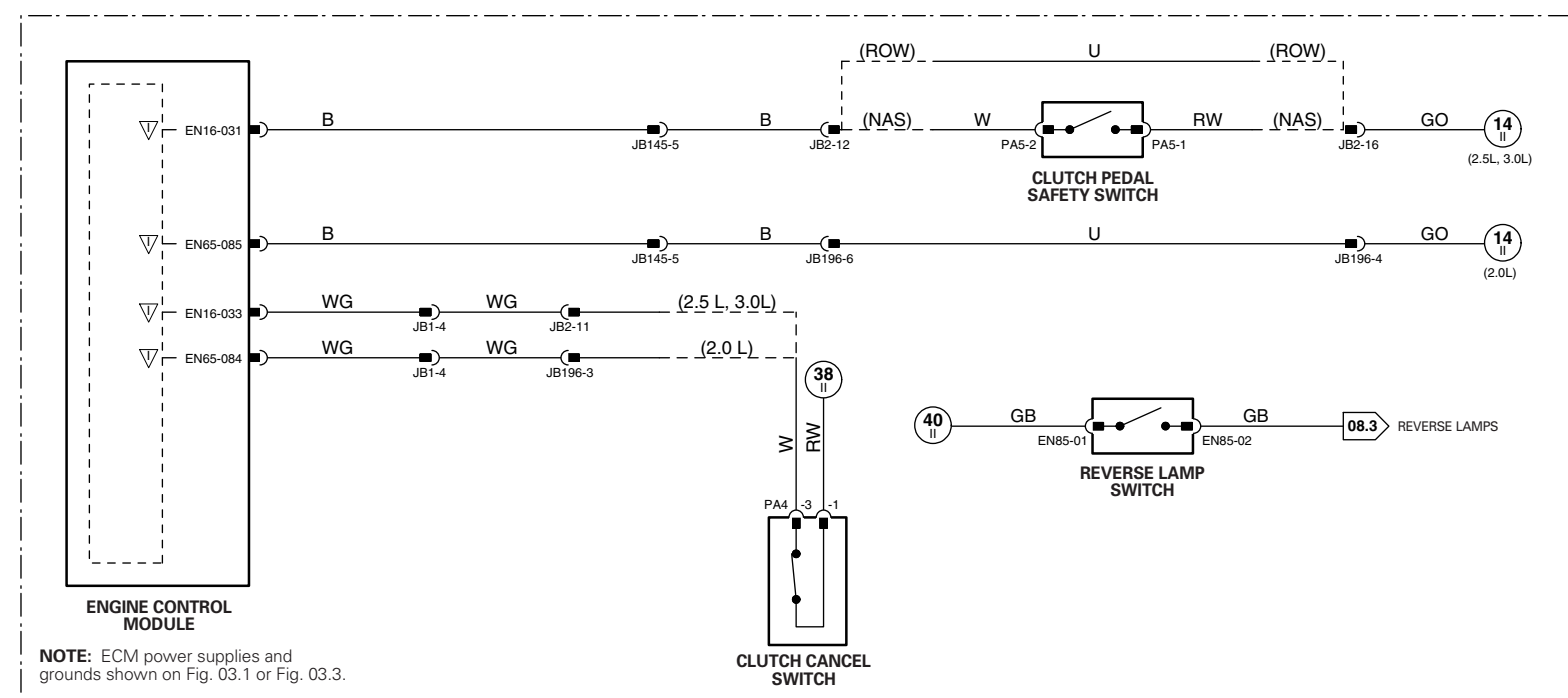
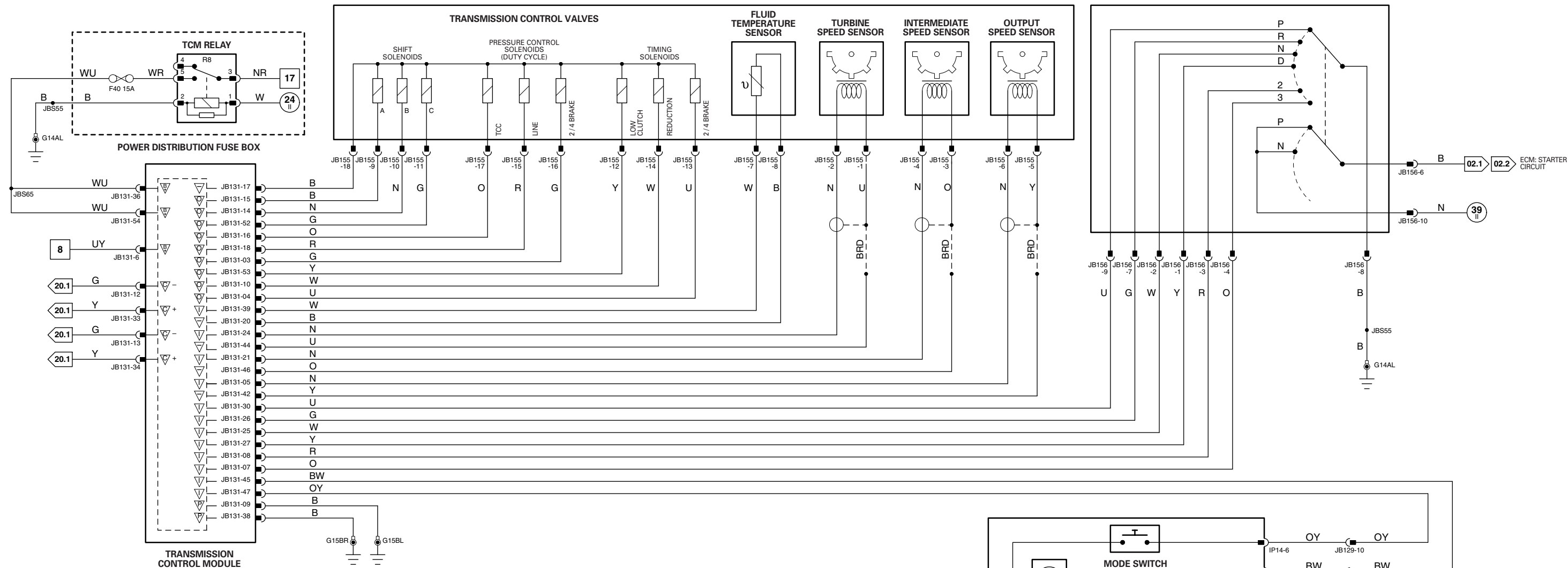

MANUAL TRANSMISSION (VIN C43293 →)

J GATE ASSEMBLY

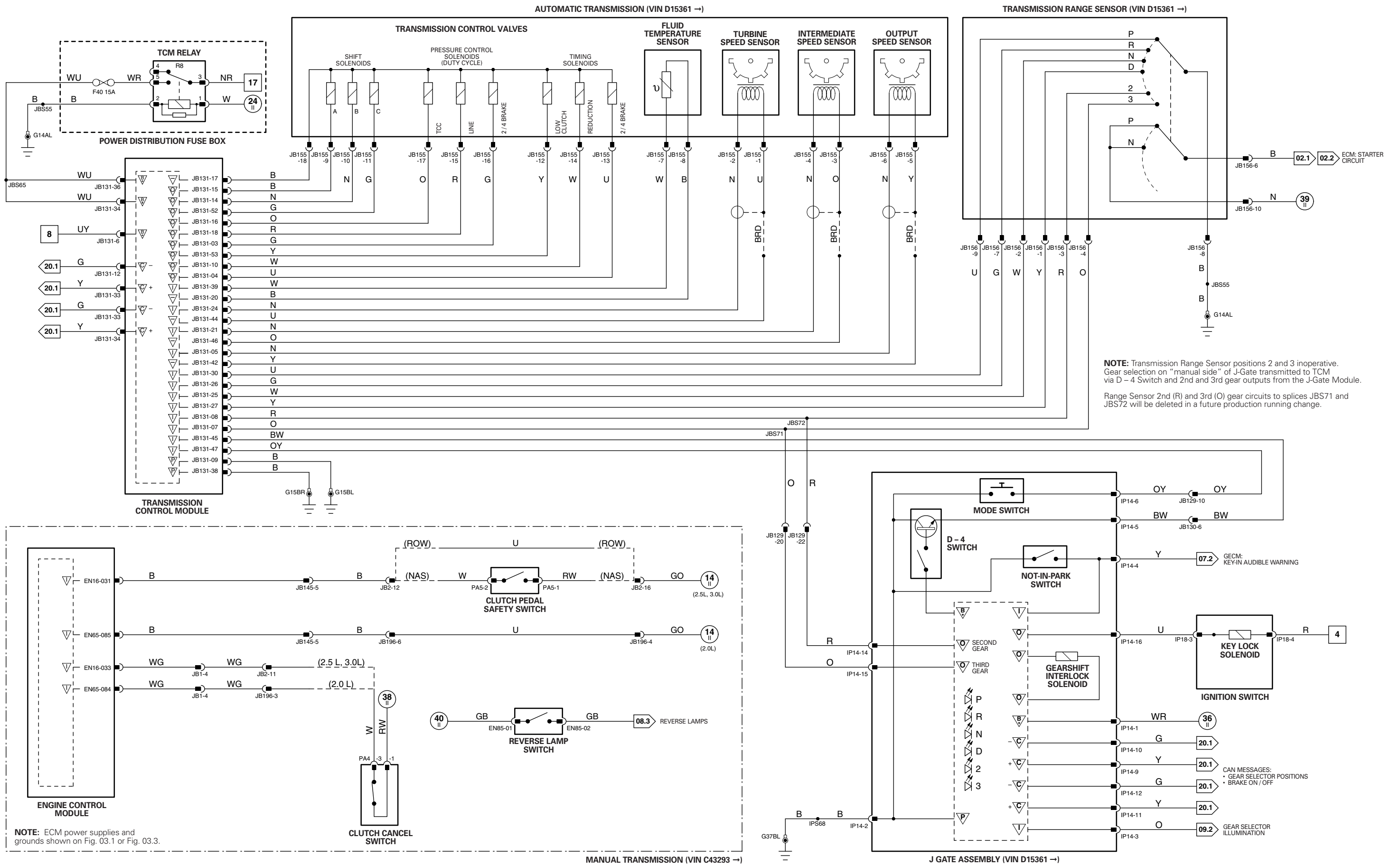

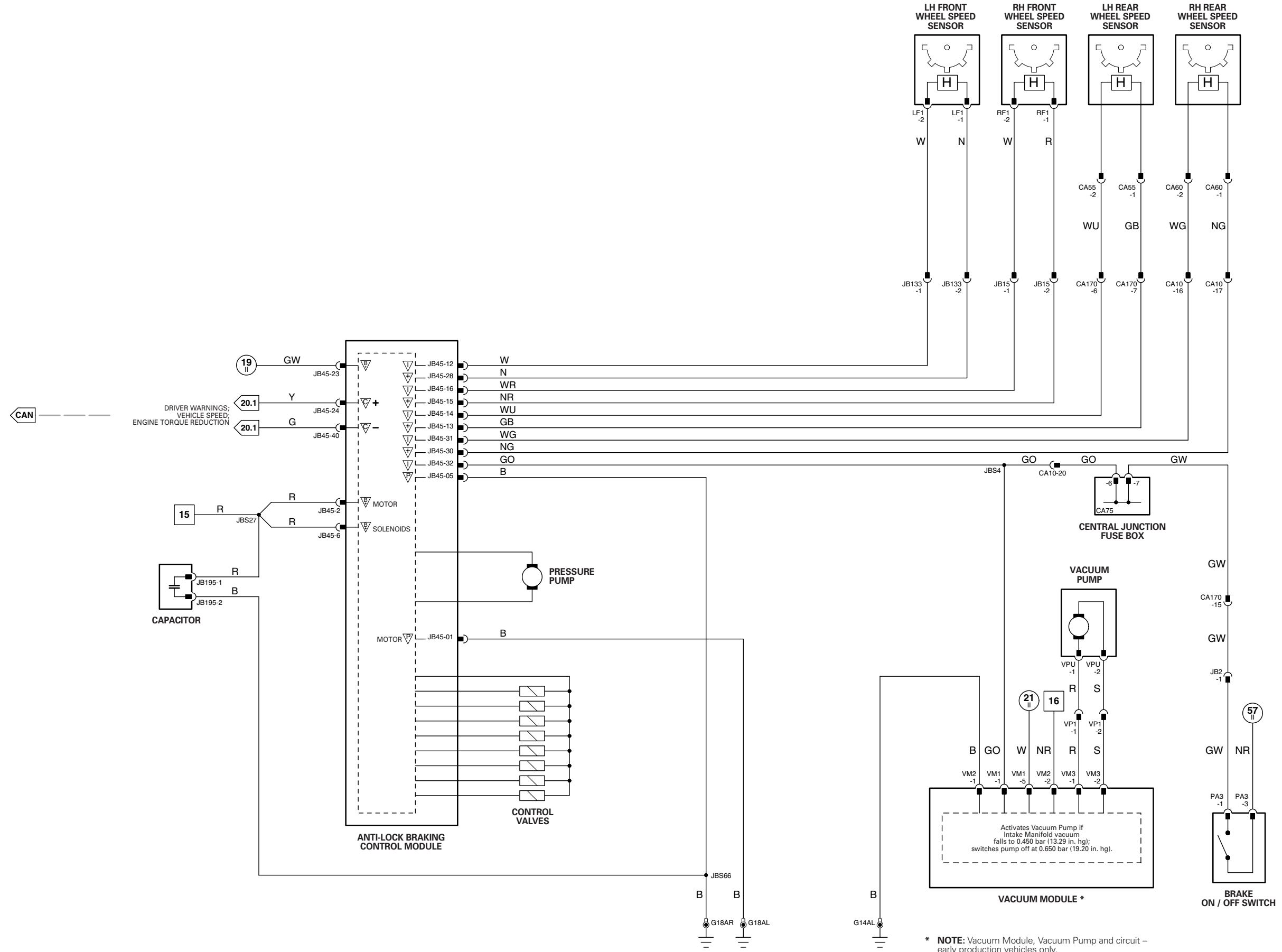

* NOTE: Vacuum Module, Vacuum Pump and circuit – early production vehicles only.

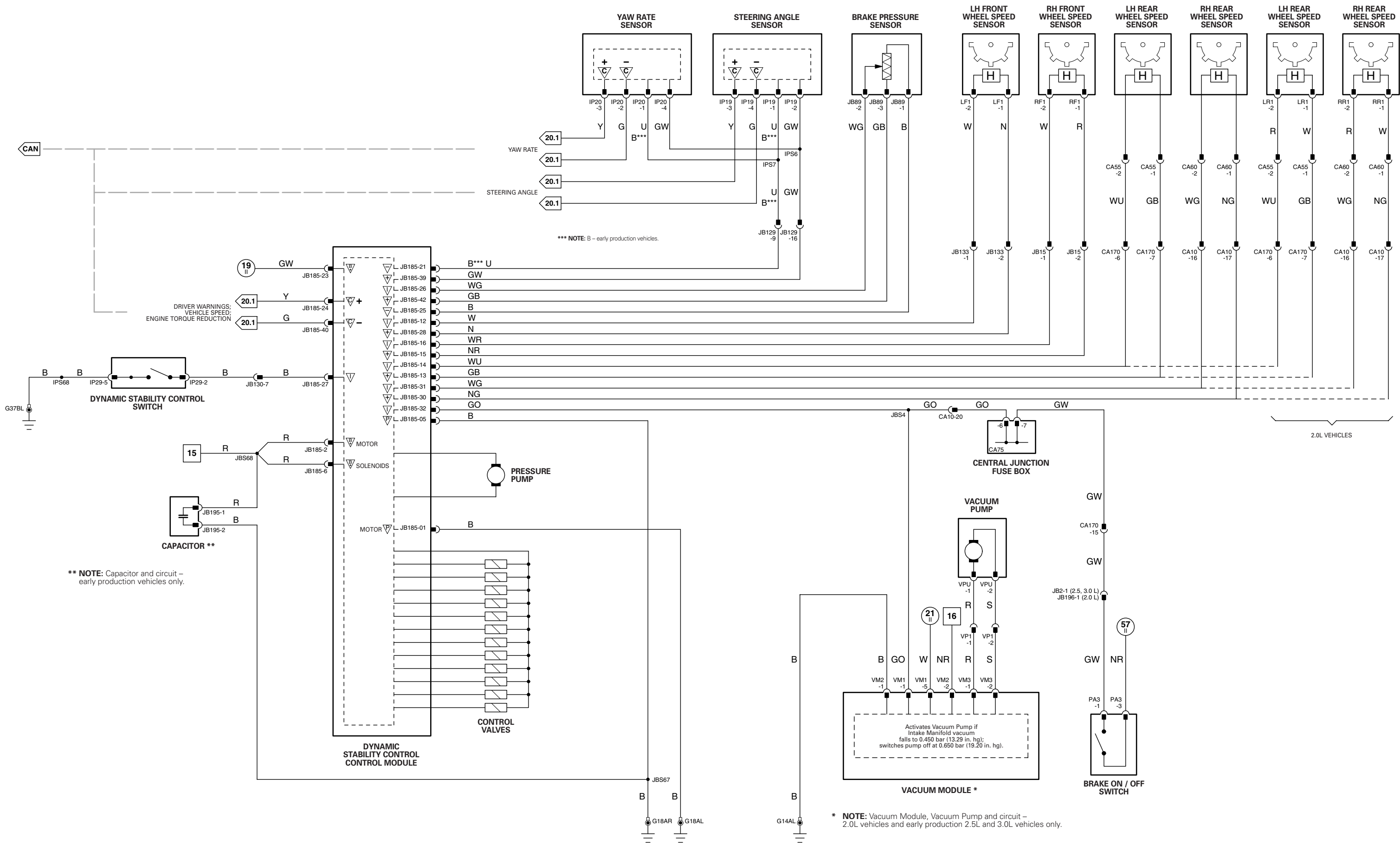

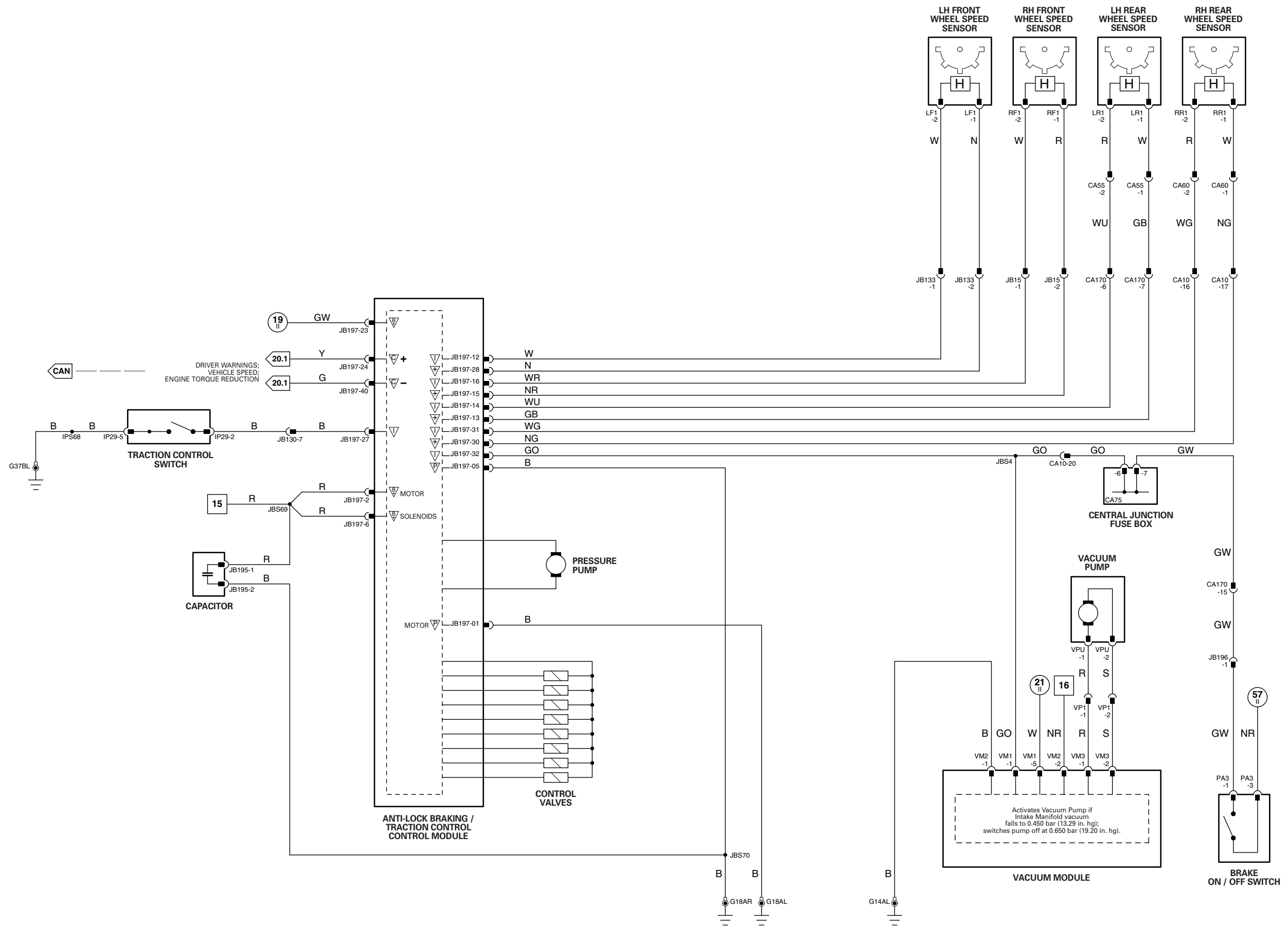



NOTE: The A/CCM incorporates the control panel for the Climate Control System.

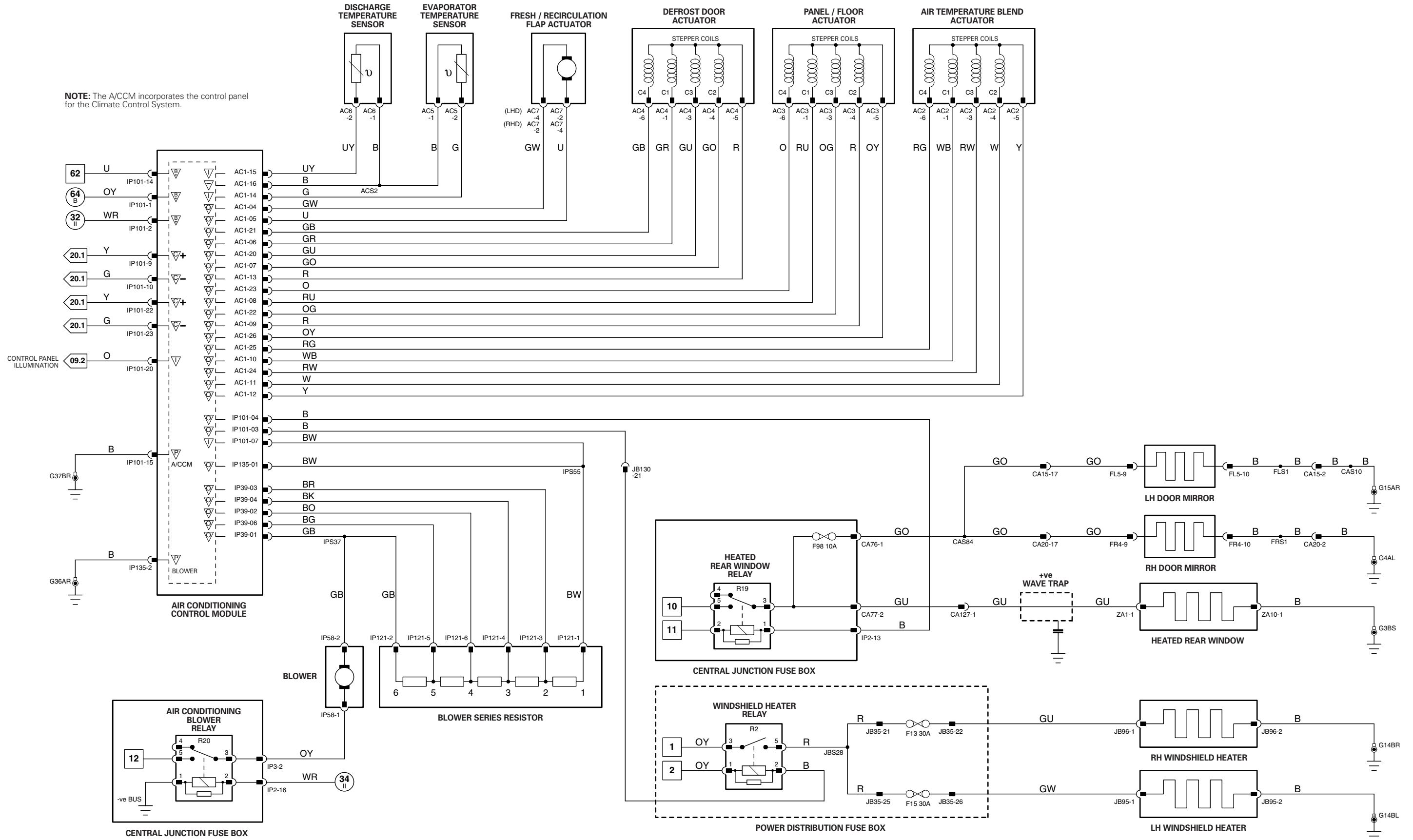

NOTES:
 Refer to Fig. 03.2 or 03.4 for A/C Compressor Clutch and Cooling Fan circuits.
 Check market specification for fitment of Heated Windshield.



NOTE:

Vehicles without Navigation "Touch Screen" - the A/CCM incorporates the Control Panel for the Climate Control System.

Vehicles with Navigation "Touch Screen" - The A/CCM is remotely mounted on the Climate Control Unit. Driver control inputs are received via Network communication.

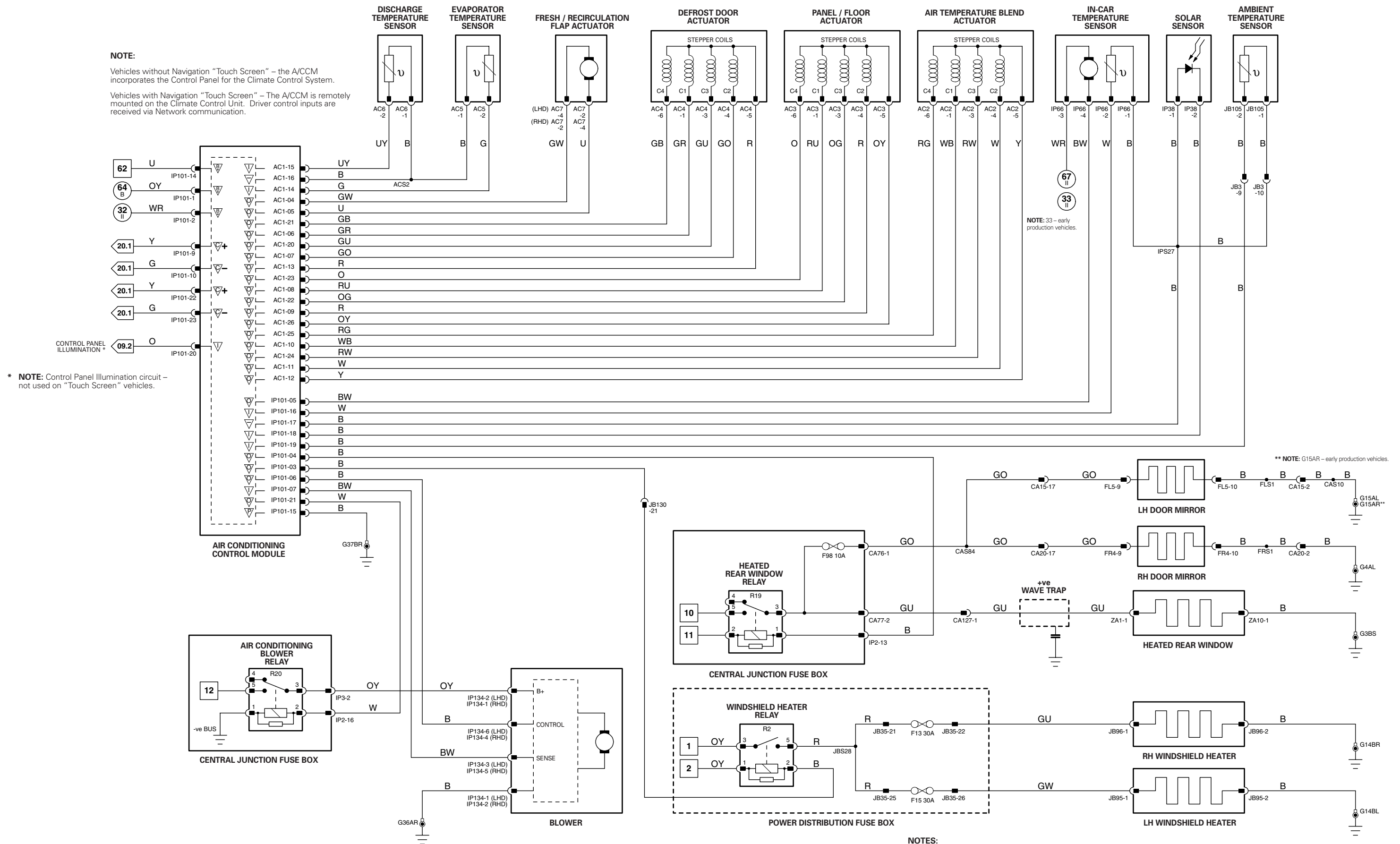

* NOTE: Control Panel Illumination circuit - not used on "Touch Screen" vehicles.

NOTE: 33 - early production vehicles.

** NOTE: G15AR - early production vehicles.

NOTES: Refer to Fig. 03.2 or Fig. 03.4 for A/C Compressor Clutch and Cooling Fan circuits. Check market specification for fitment of Heated Windshield.

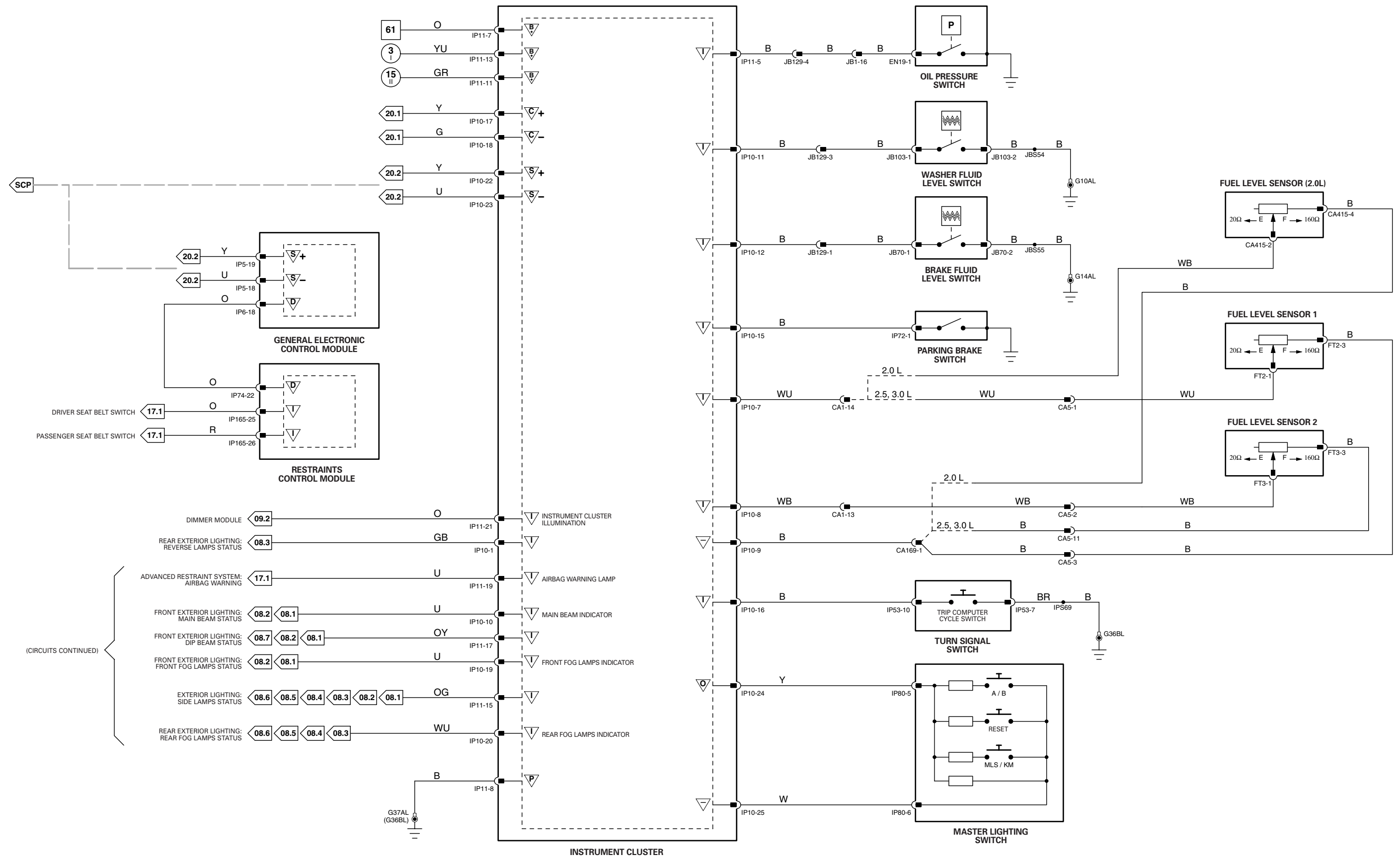

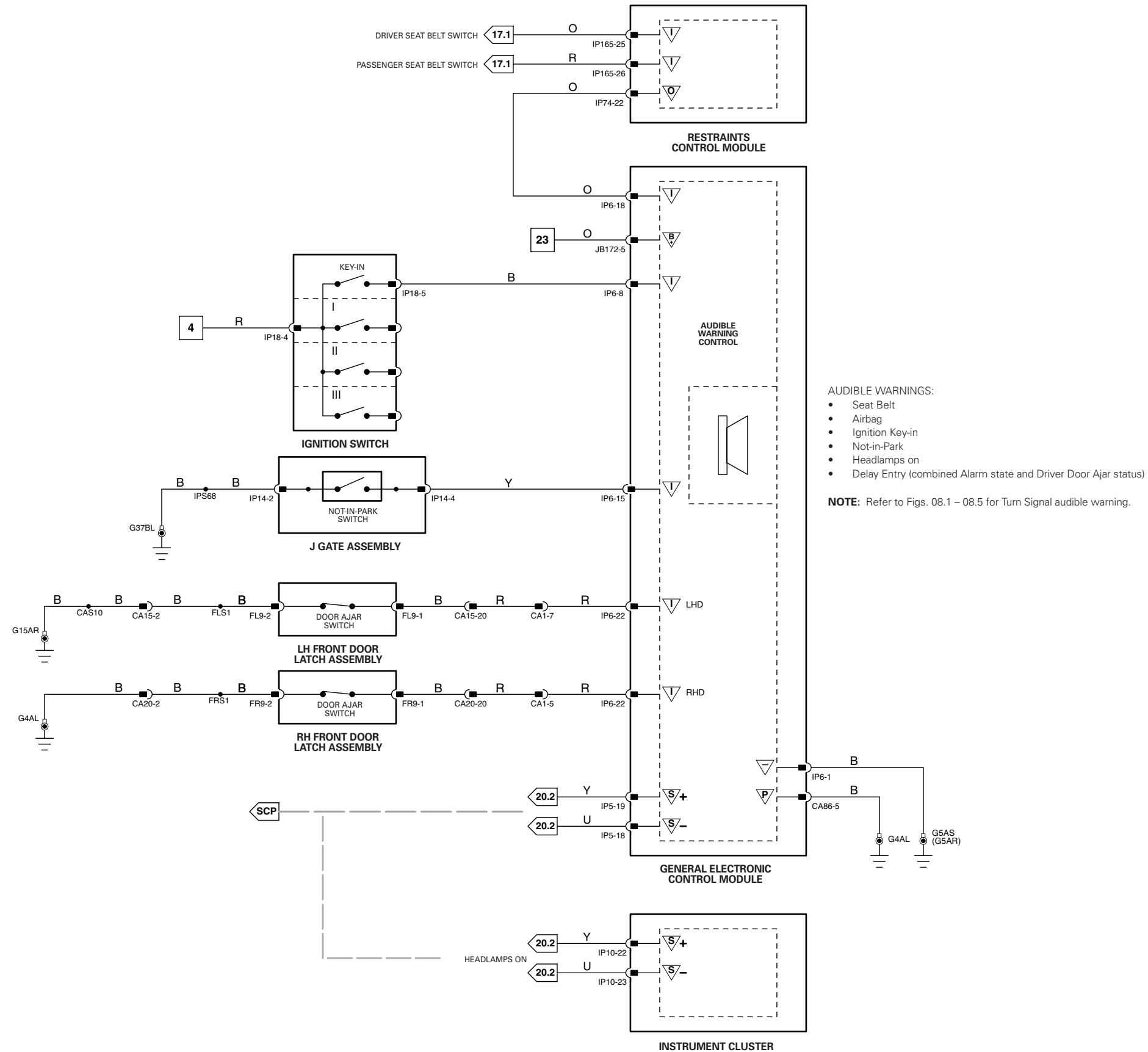

- AUDIBLE WARNINGS:**
- Seat Belt
 - Airbag
 - Ignition Key-in
 - Not-in-Park
 - Headlamps on
 - Delay Entry (combined Alarm state and Driver Door Ajar status)
- NOTE:** Refer to Figs. 08.1 – 08.5 for Turn Signal audible warning.

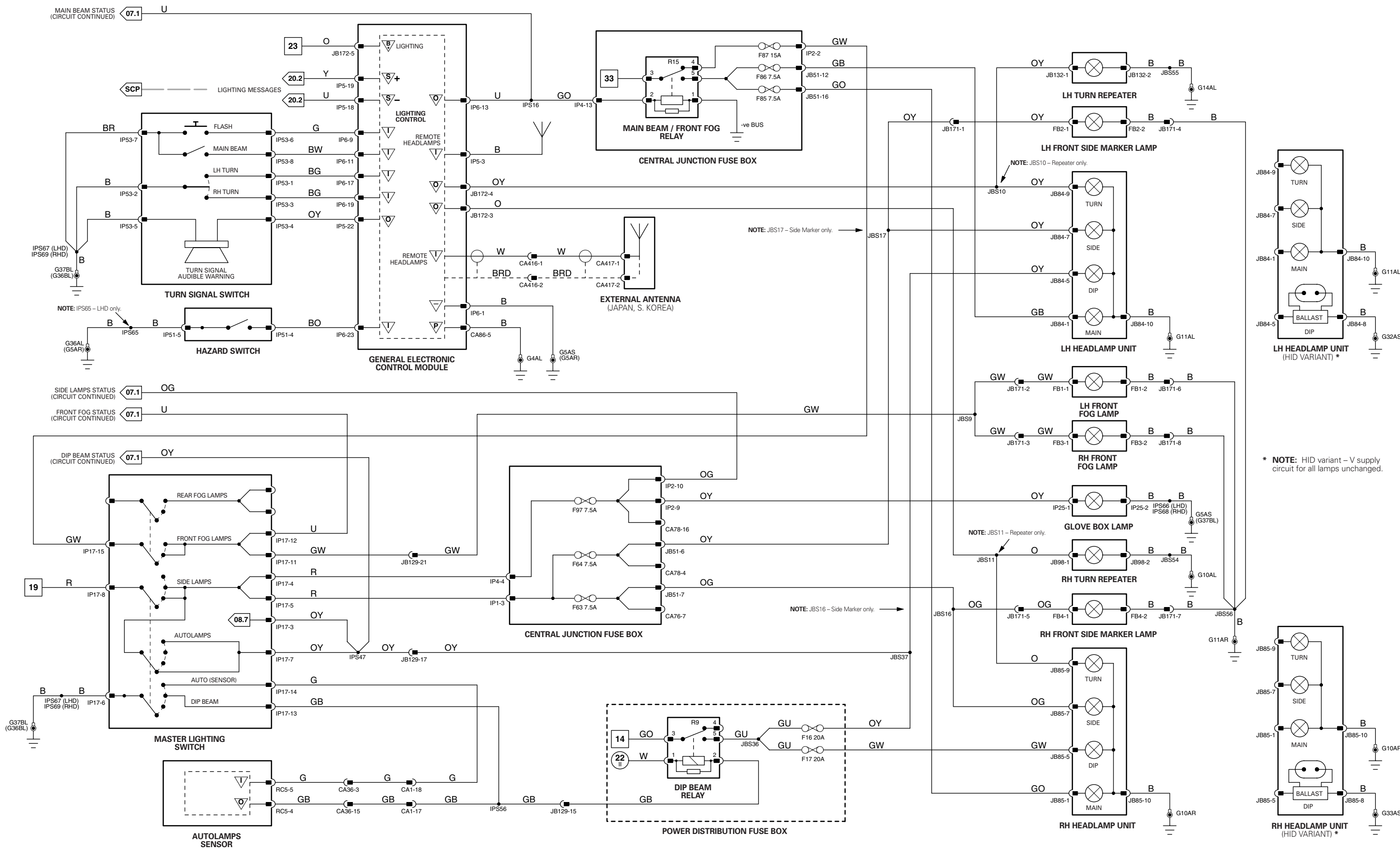

* NOTE: HID variant – V supply circuit for all lamps unchanged.

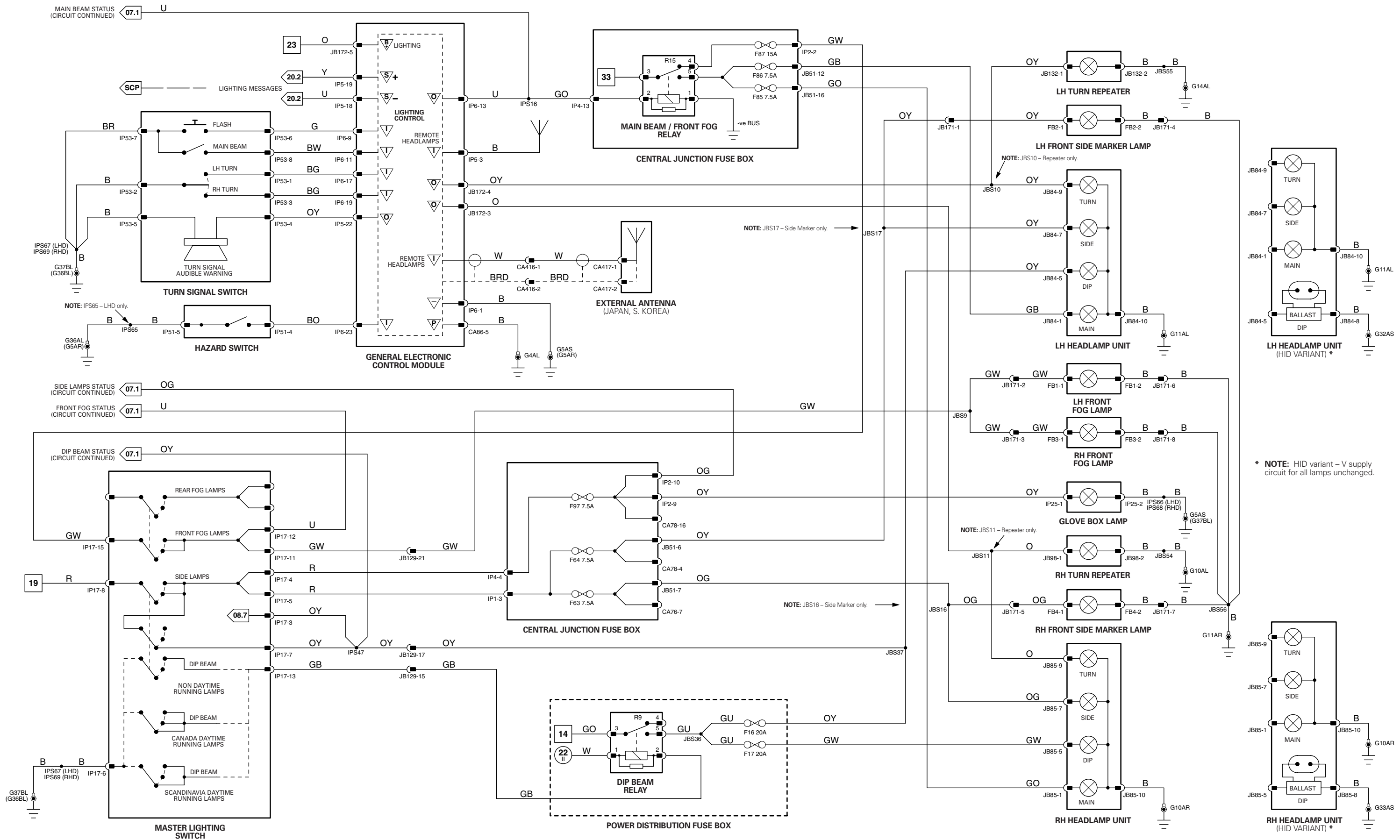

* NOTE: HID variant – V supply circuit for all lamps unchanged.

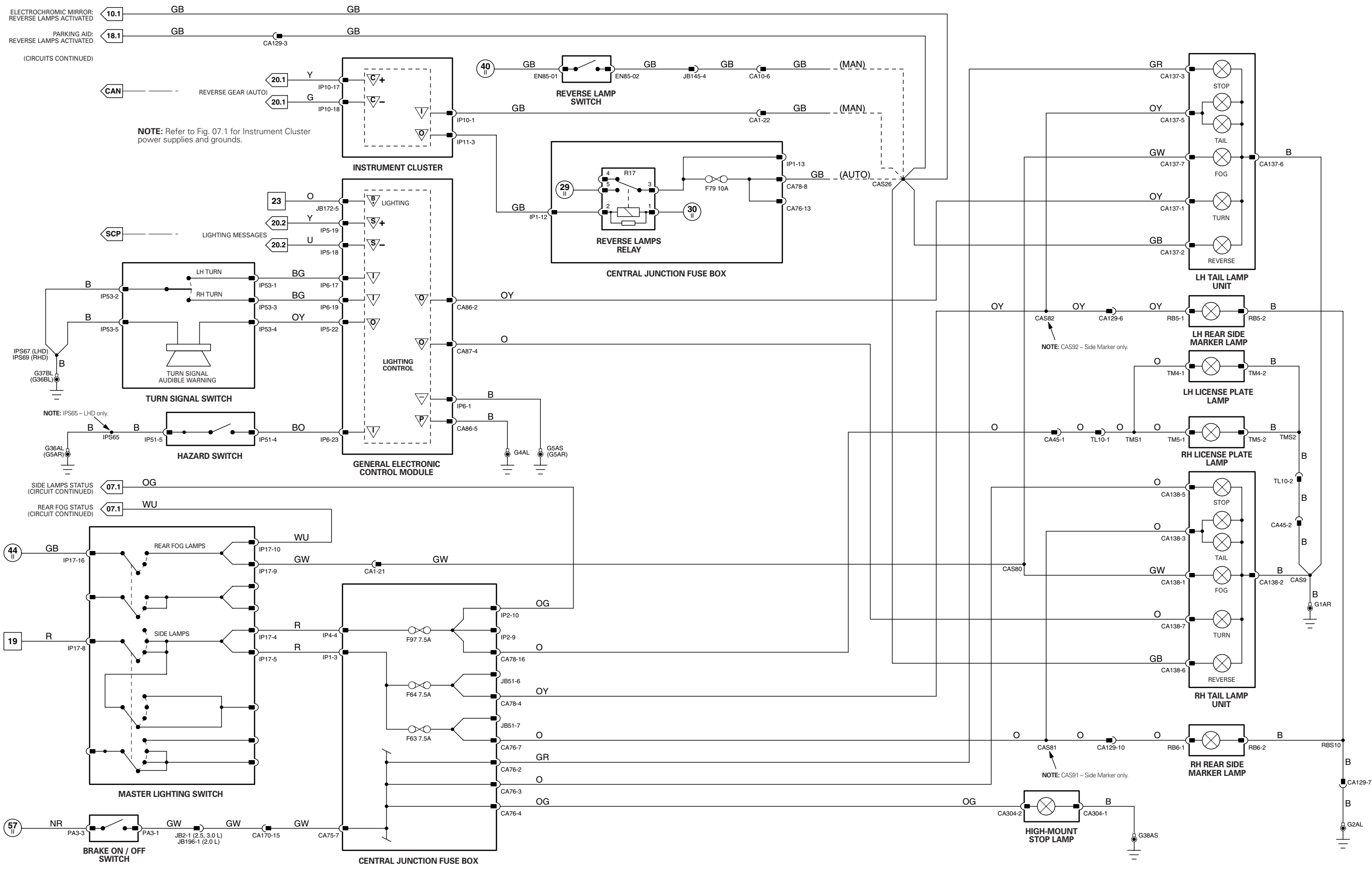

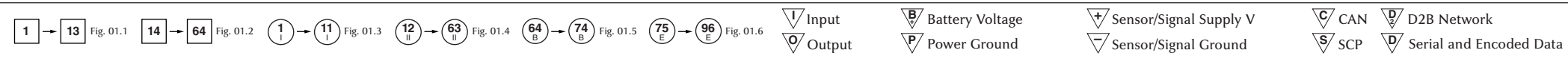
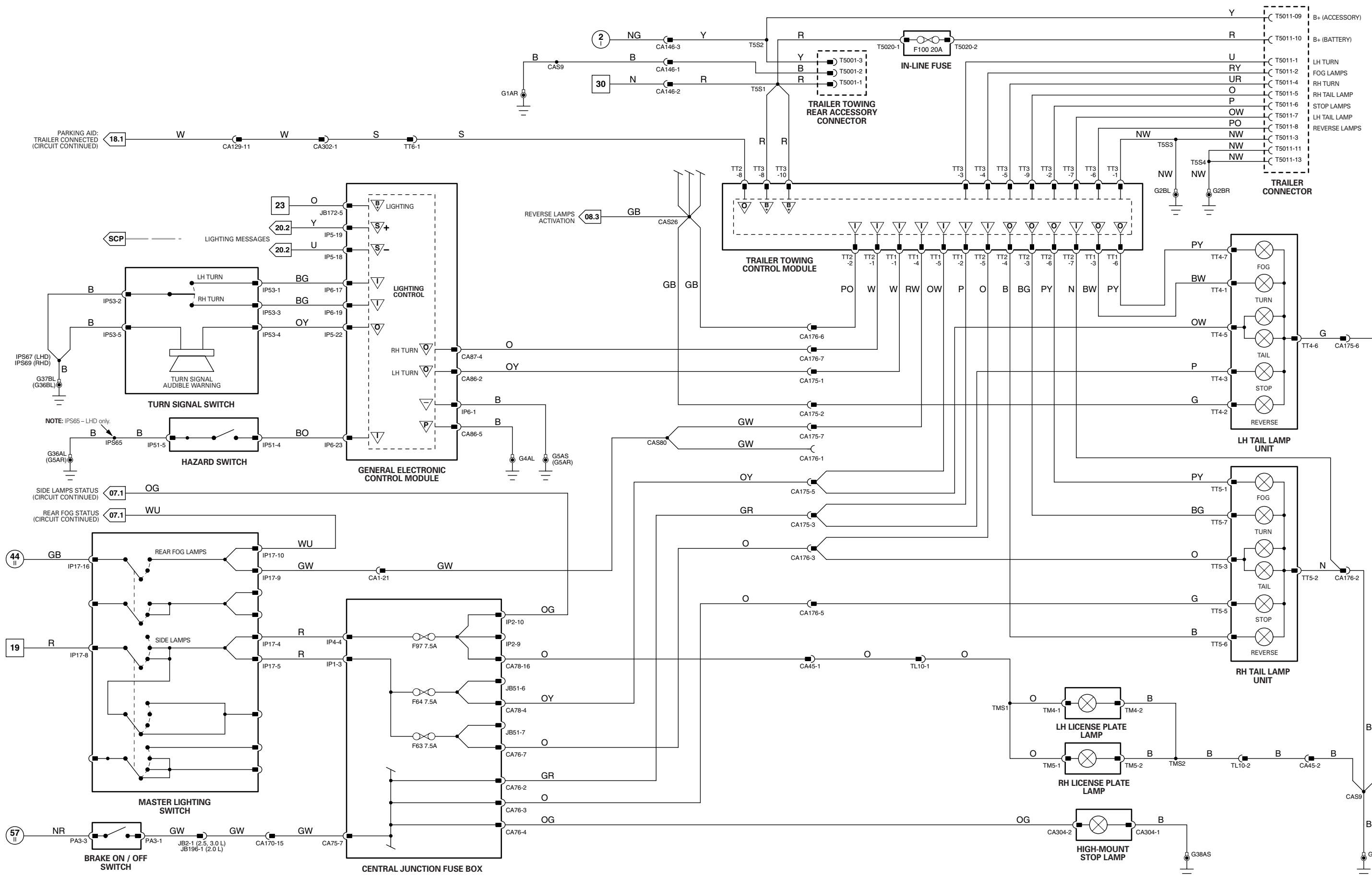

VARIANT: EUR Trailer Towing Vehicles
 VIN RANGE: All
 DATE OF ISSUE: December 2001

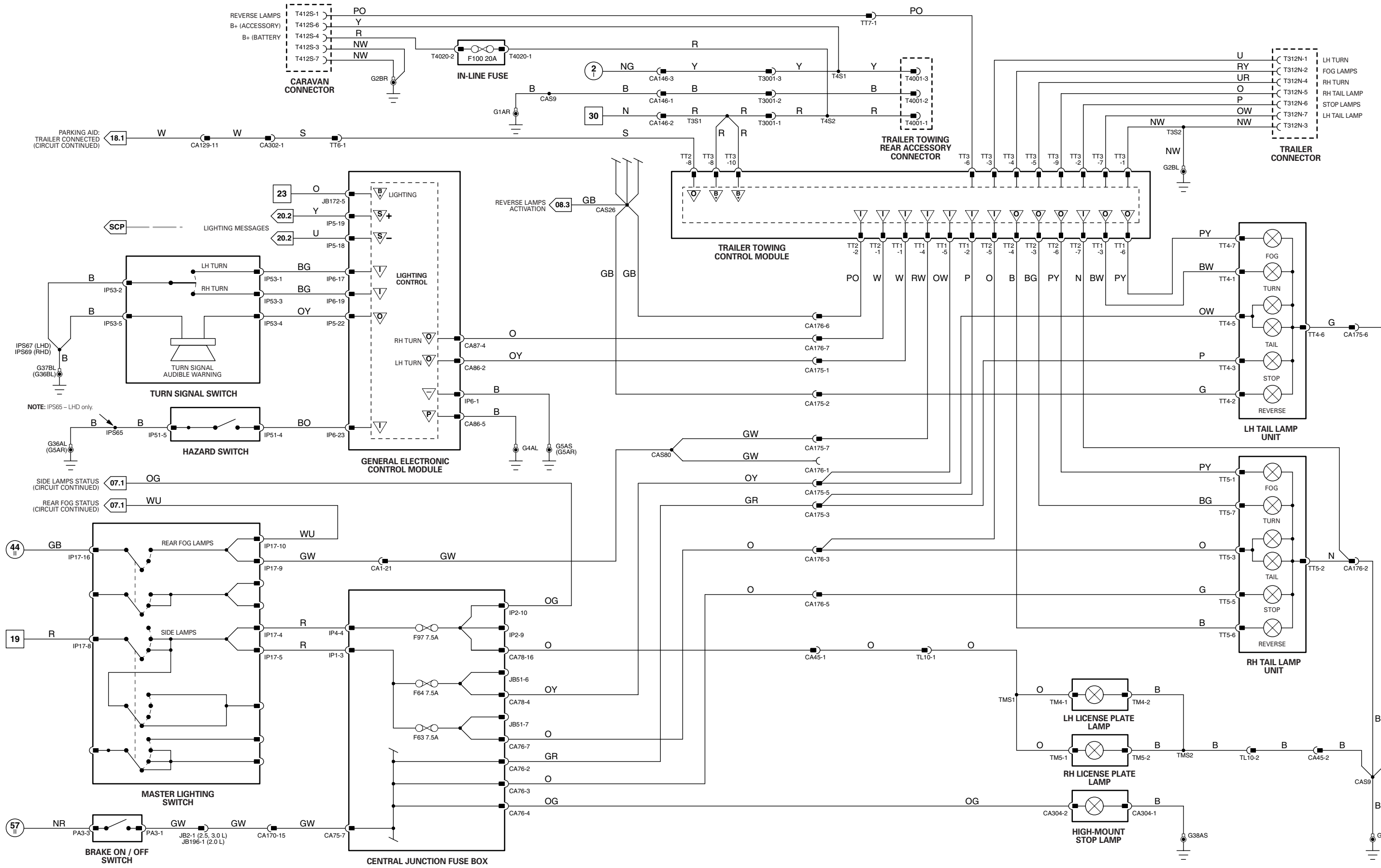

1	13	Fig. 01.1	14	64	Fig. 01.2	1	11	Fig. 01.3	12	63	Fig. 01.4	64	74	Fig. 01.5	75	96	Fig. 01.6
Input	Battery Voltage	Sensor/Signal Supply V	CAN	D2B Network	Output	Power Ground	Sensor/Signal Ground	SCP	Serial and Encoded Data								

VARIANT: U.K. Trailer Towing Vehicles
 VIN RANGE: All
 DATE OF ISSUE: December 2001

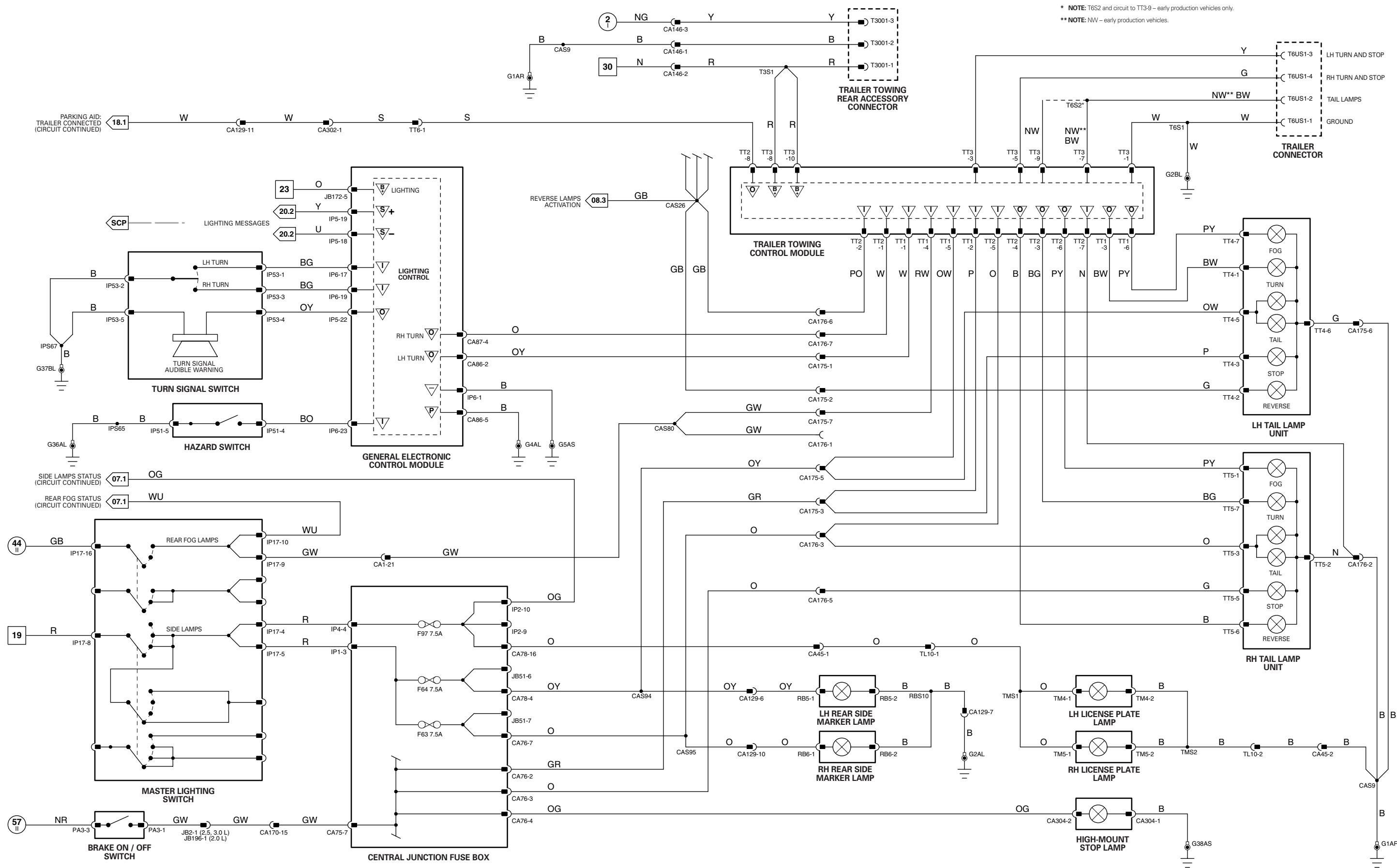

* NOTE: T6S2 and circuit to TT3-9 – early production vehicles only.
 ** NOTE: NW – early production vehicles.

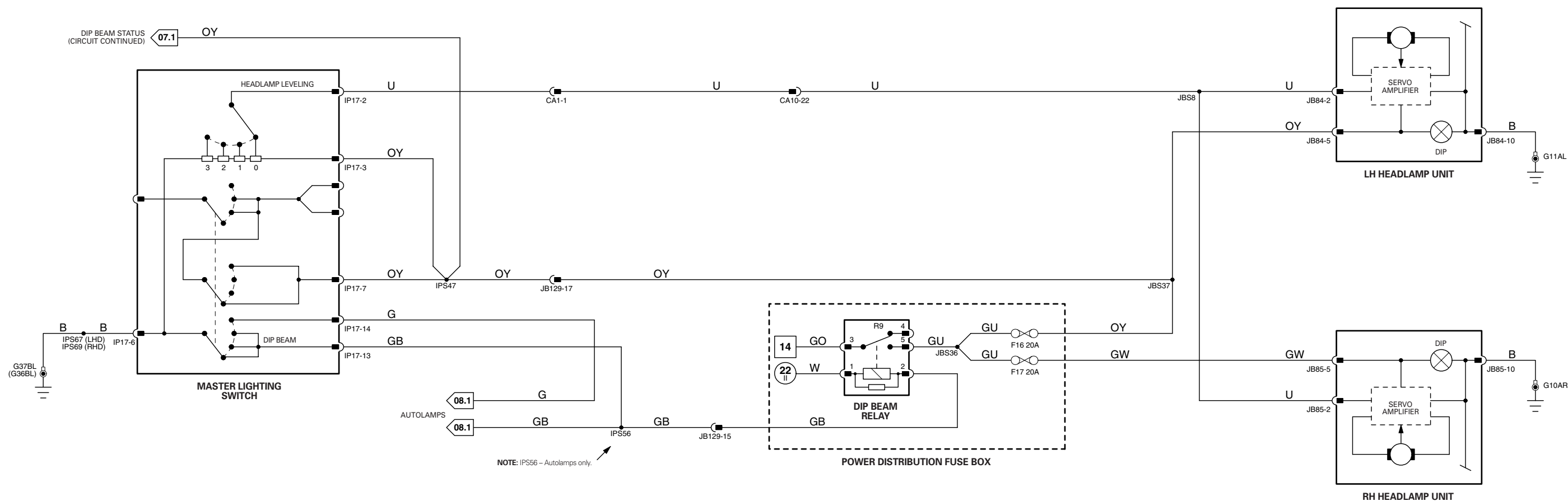

DRIVER-CONTROLLED HEADLAMP LEVELING

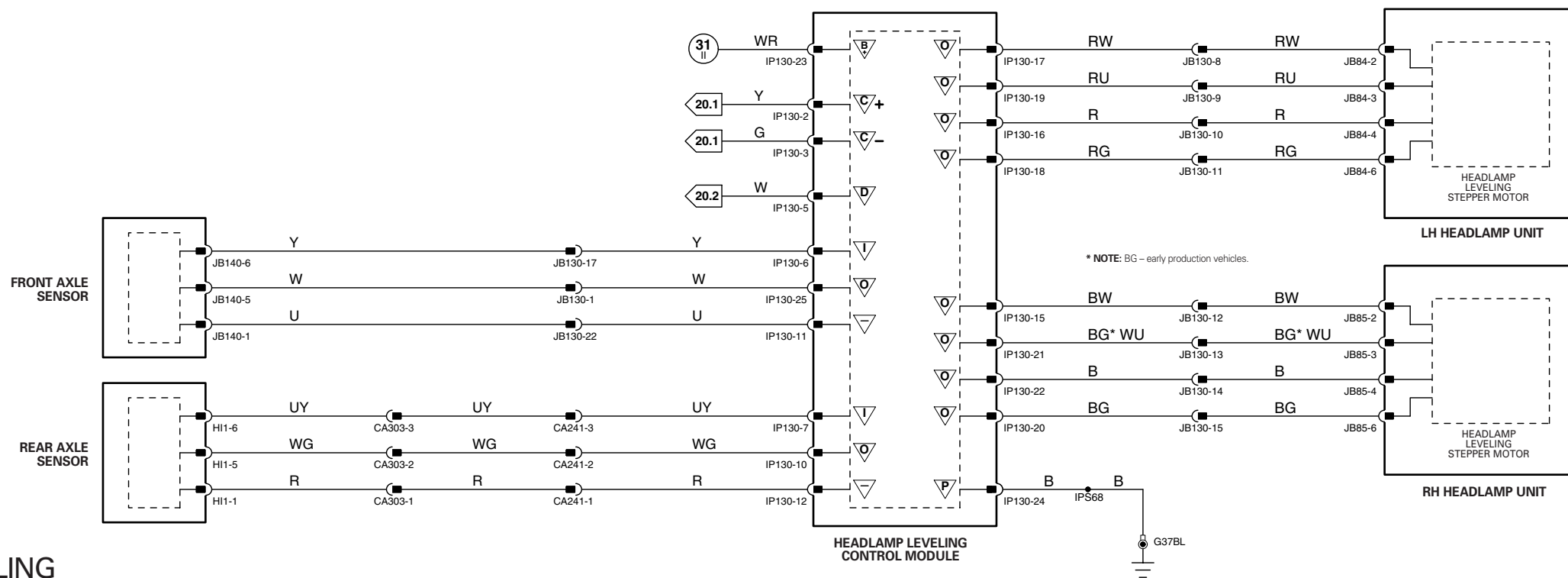

AUTOMATIC HEADLAMP LEVELING

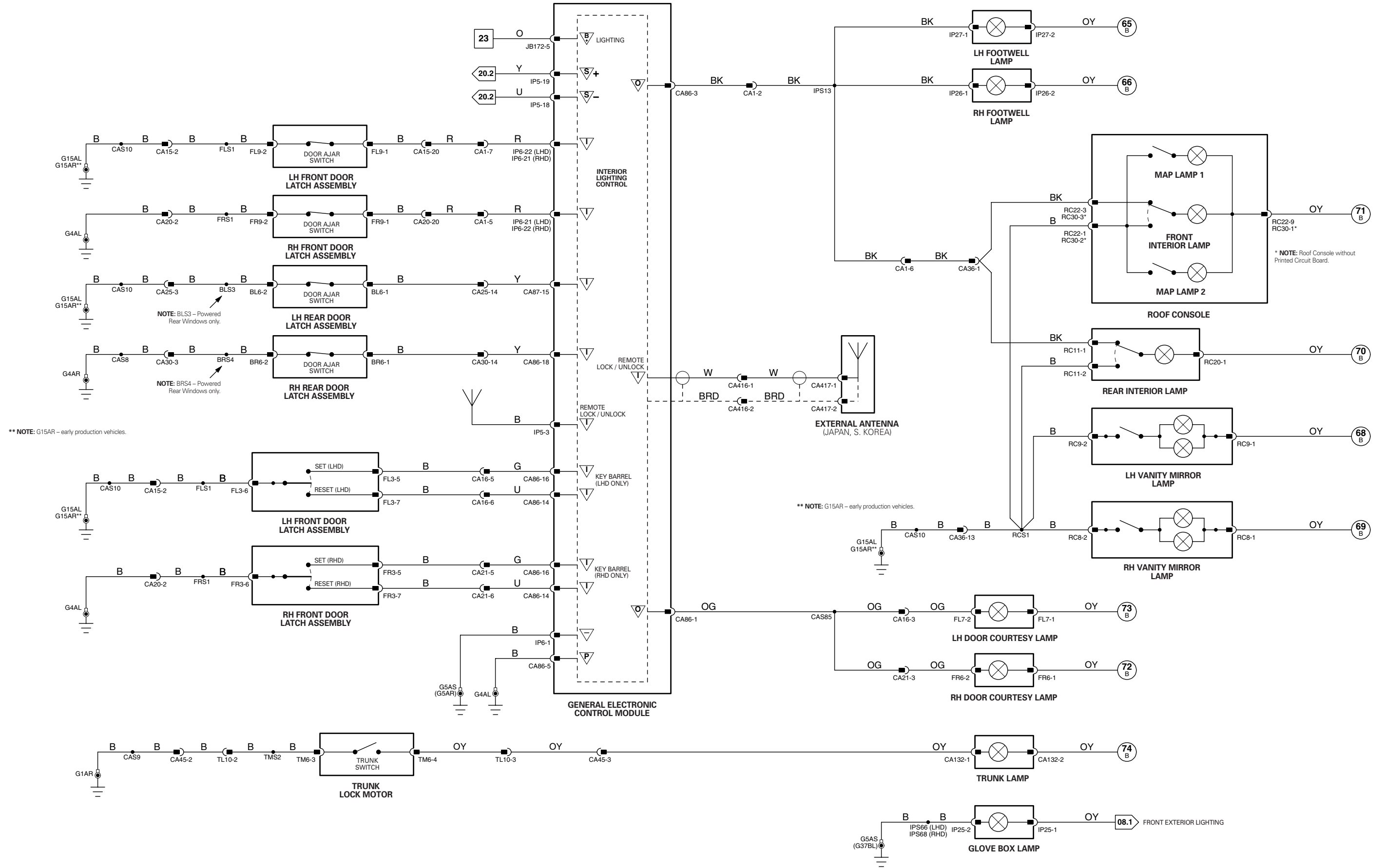

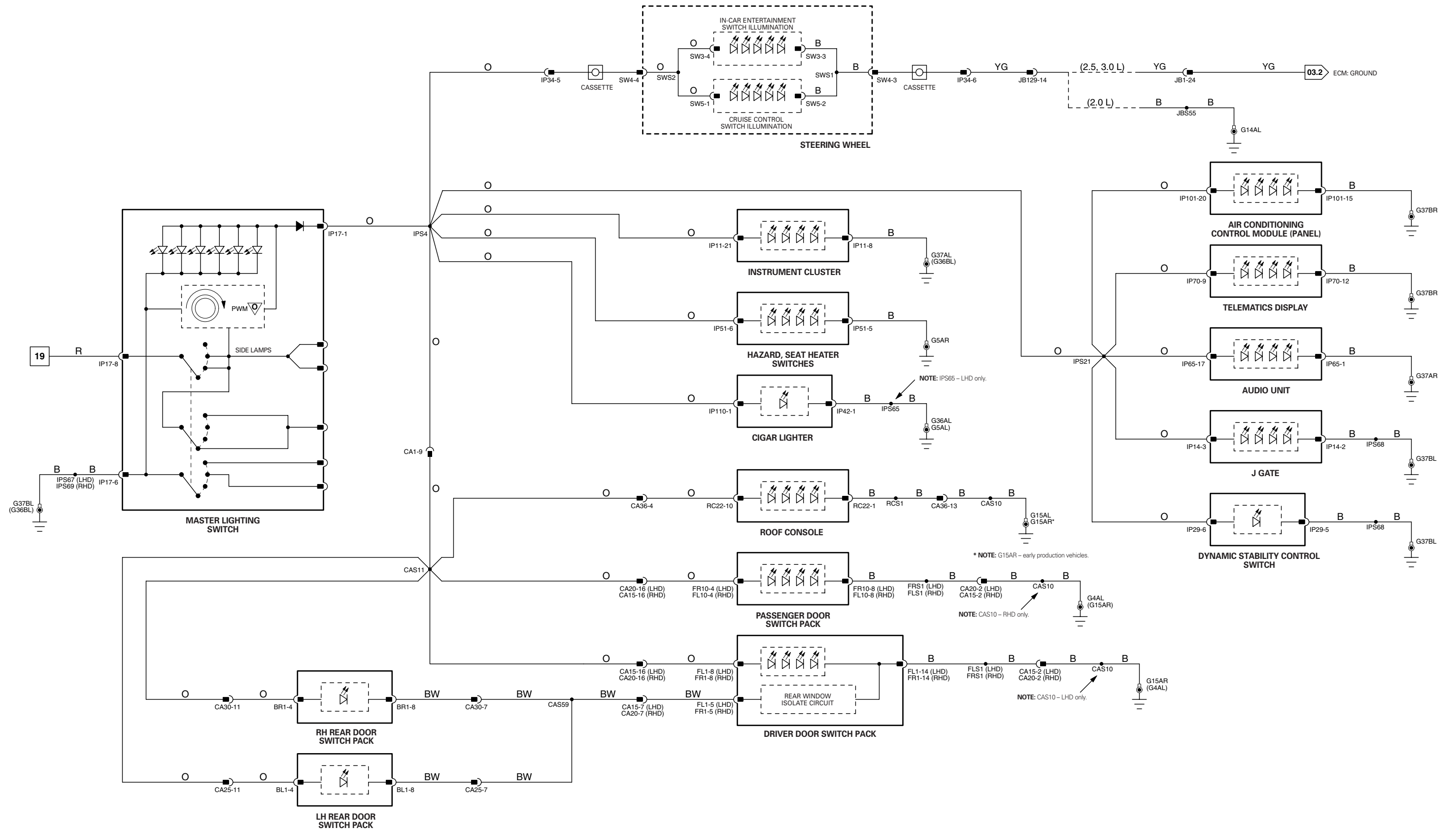

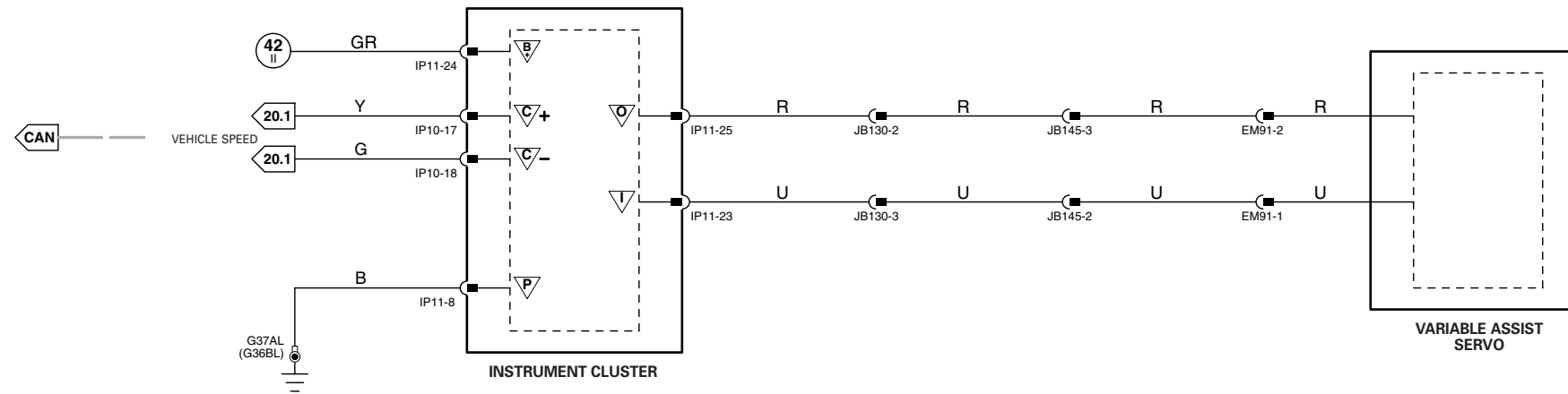

VARIABLE ASSIST STEERING

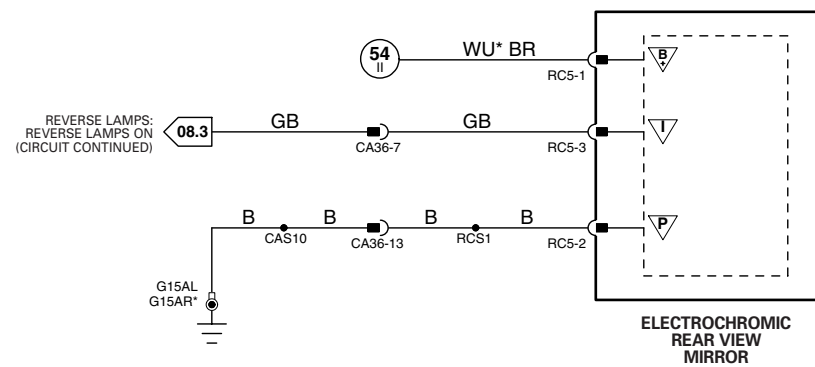

* NOTE: G15AR, WU – early production vehicles.

ELECTROCHROMIC REAR VIEW MIRROR

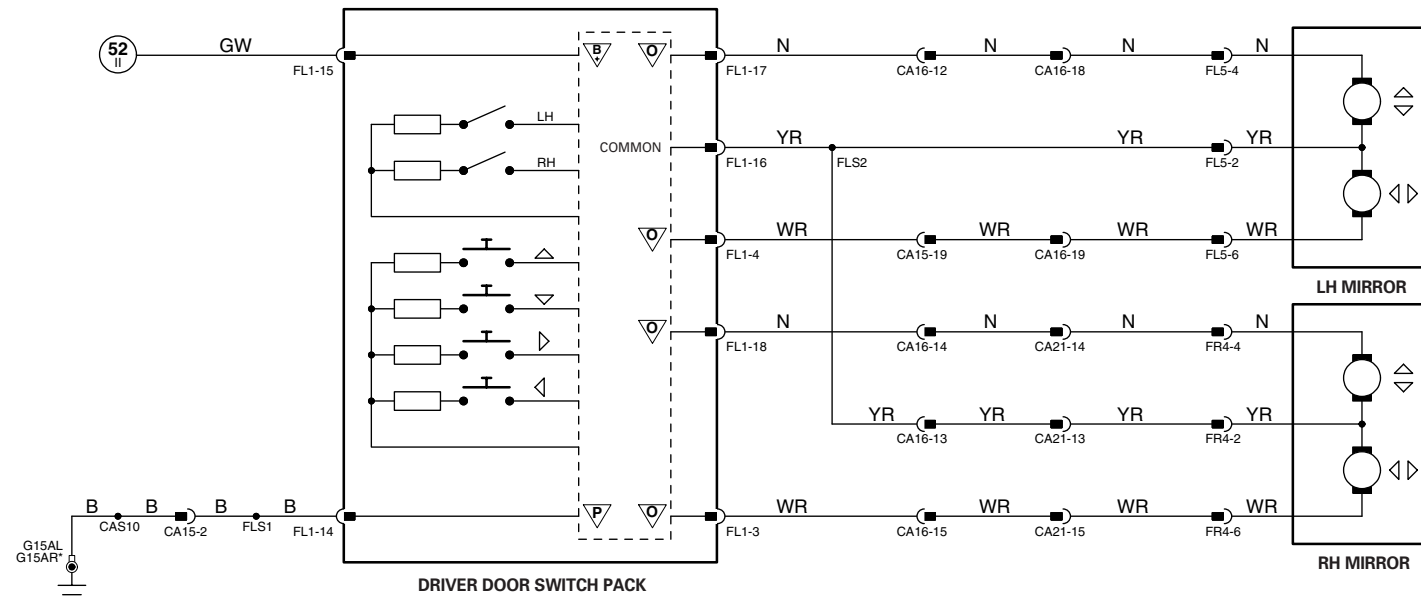

* NOTE: G15AR - early production vehicles.

DOOR MIRROR MOVEMENT: LHD

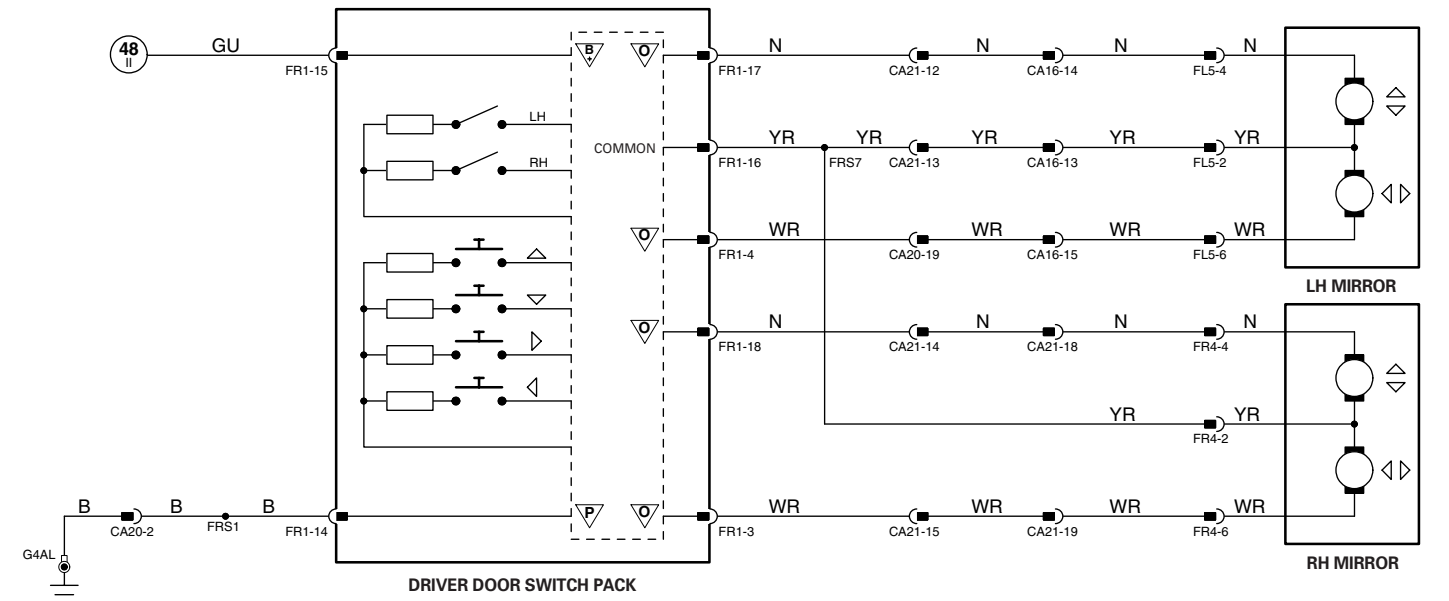

DOOR MIRROR MOVEMENT: RHD

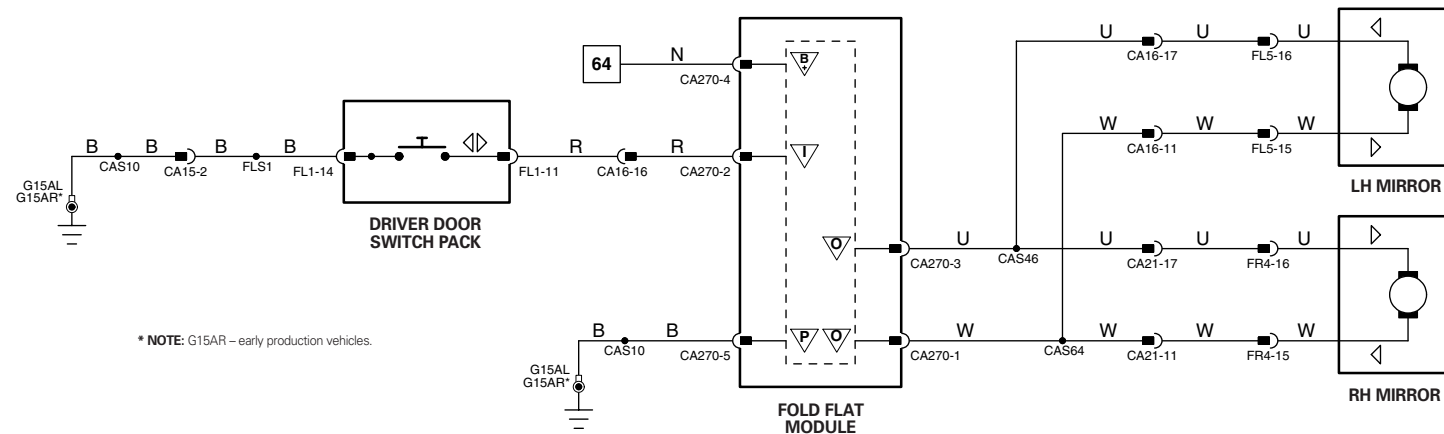

* NOTE: G15AR - early production vehicles.

DOOR MIRROR FOLD: LHD

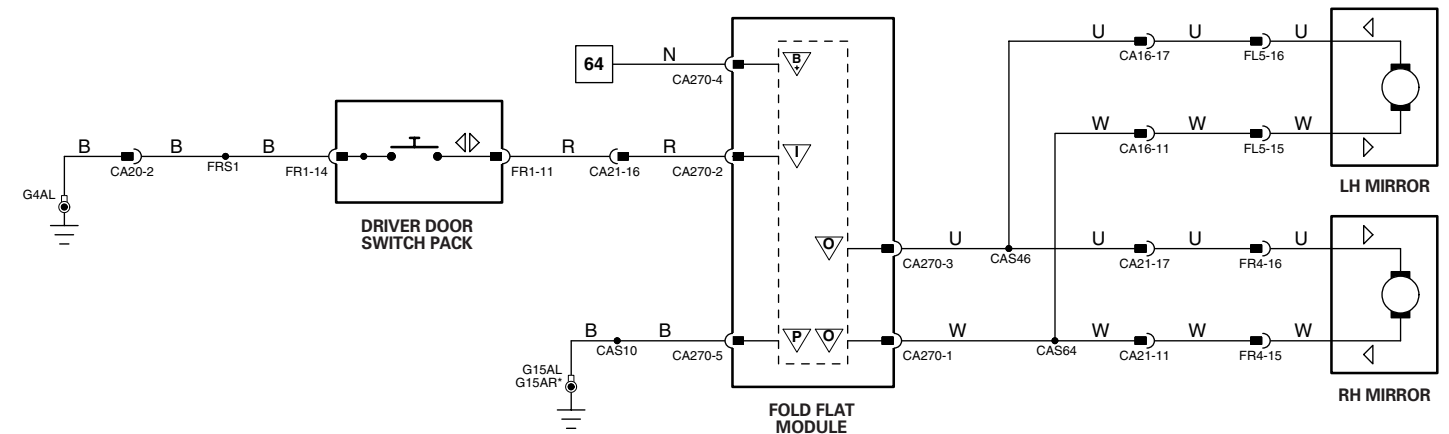

* NOTE: G15AR - early production vehicles.

DOOR MIRROR FOLD: RHD

NOTE: Refer to Figures 06.1 and 06.2 for Mirror Heaters.



NOTE:

40 - Non Heated Seat.
42 - Heated Seat.

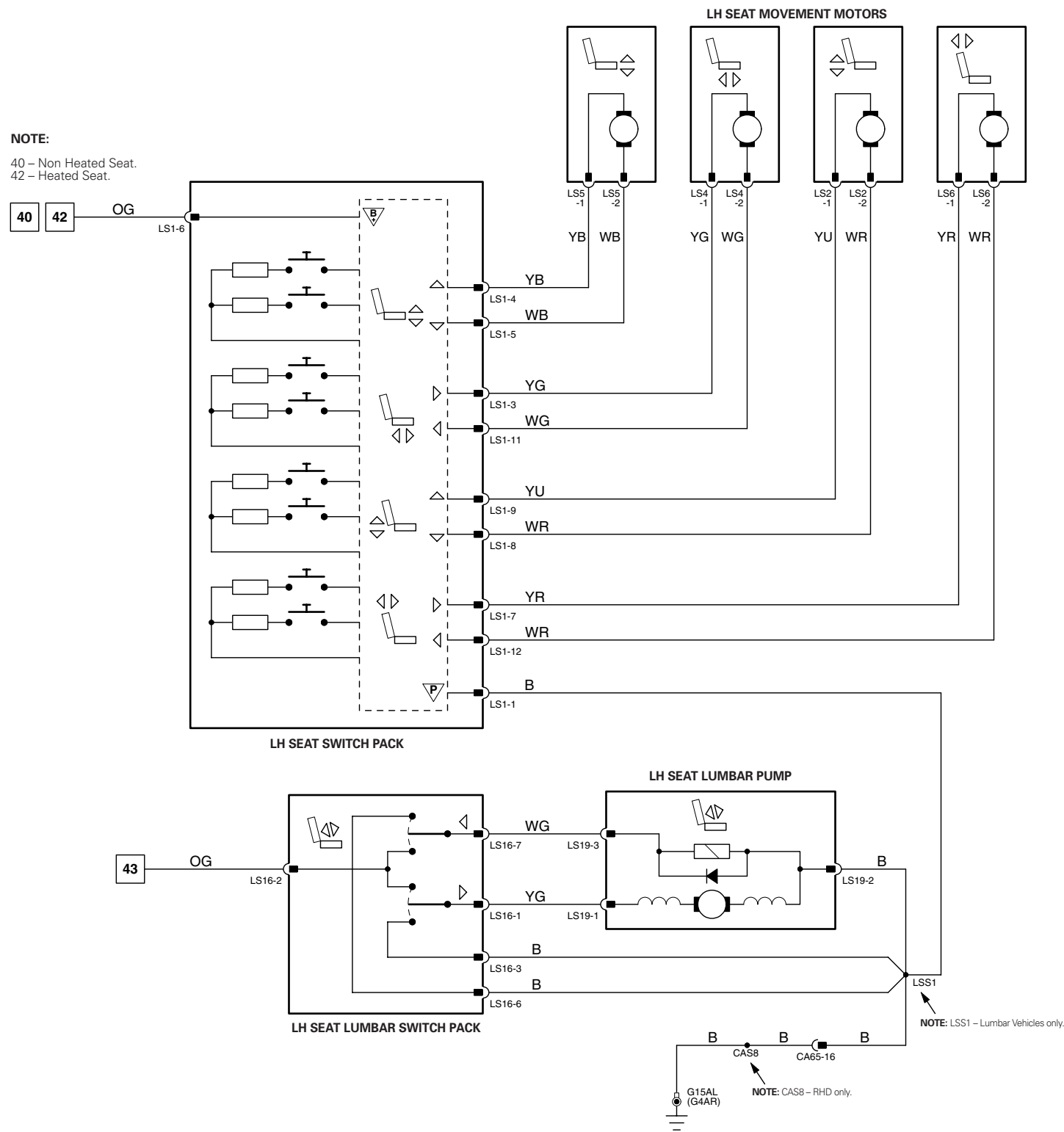

LH SEAT

NOTE:

45 - Non Heated Seat.
47 - Heated Seat.

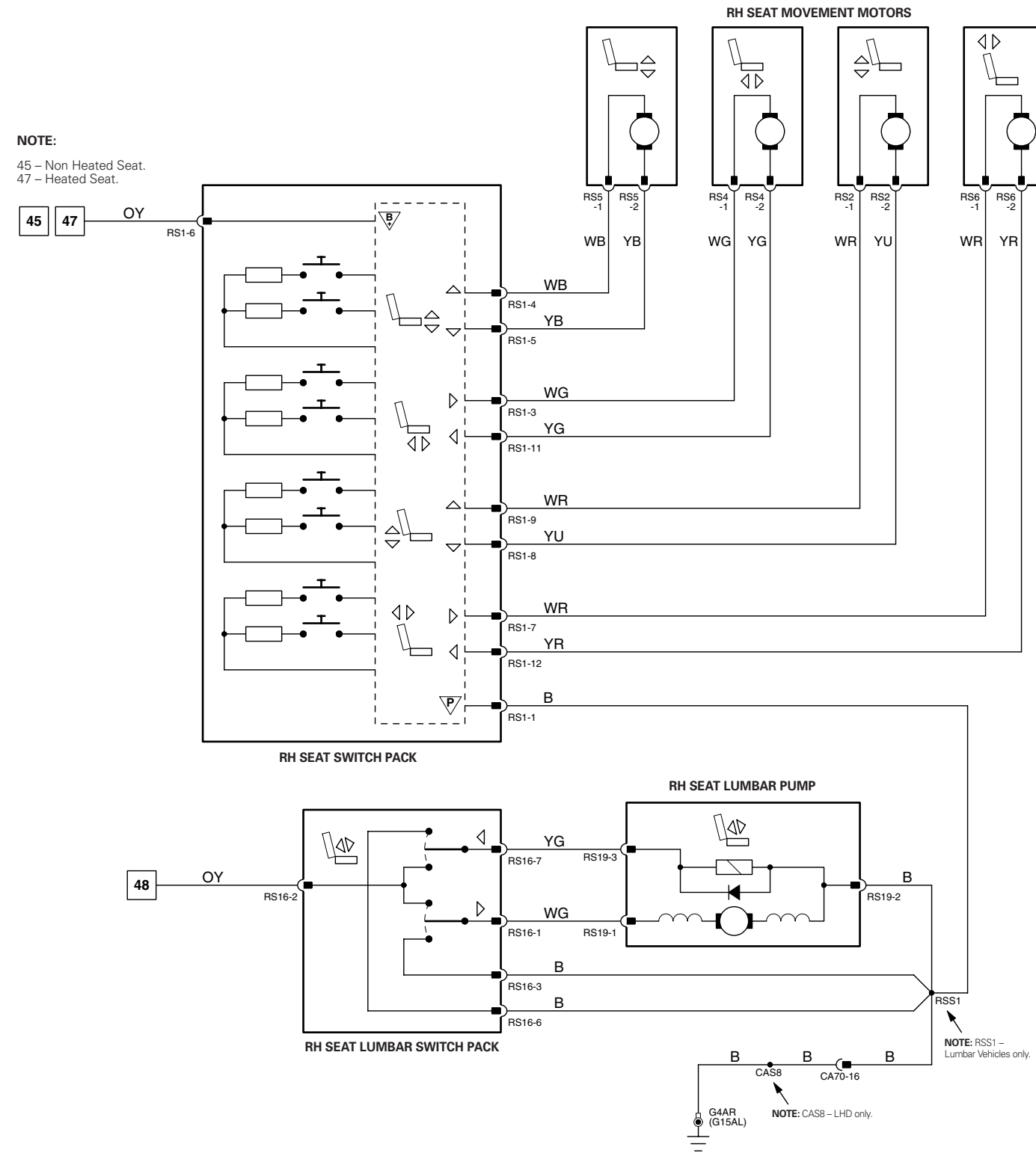

RH SEAT

NOTE: Powered Lumbar Circuit and components - Powered Lumbar Seats only.

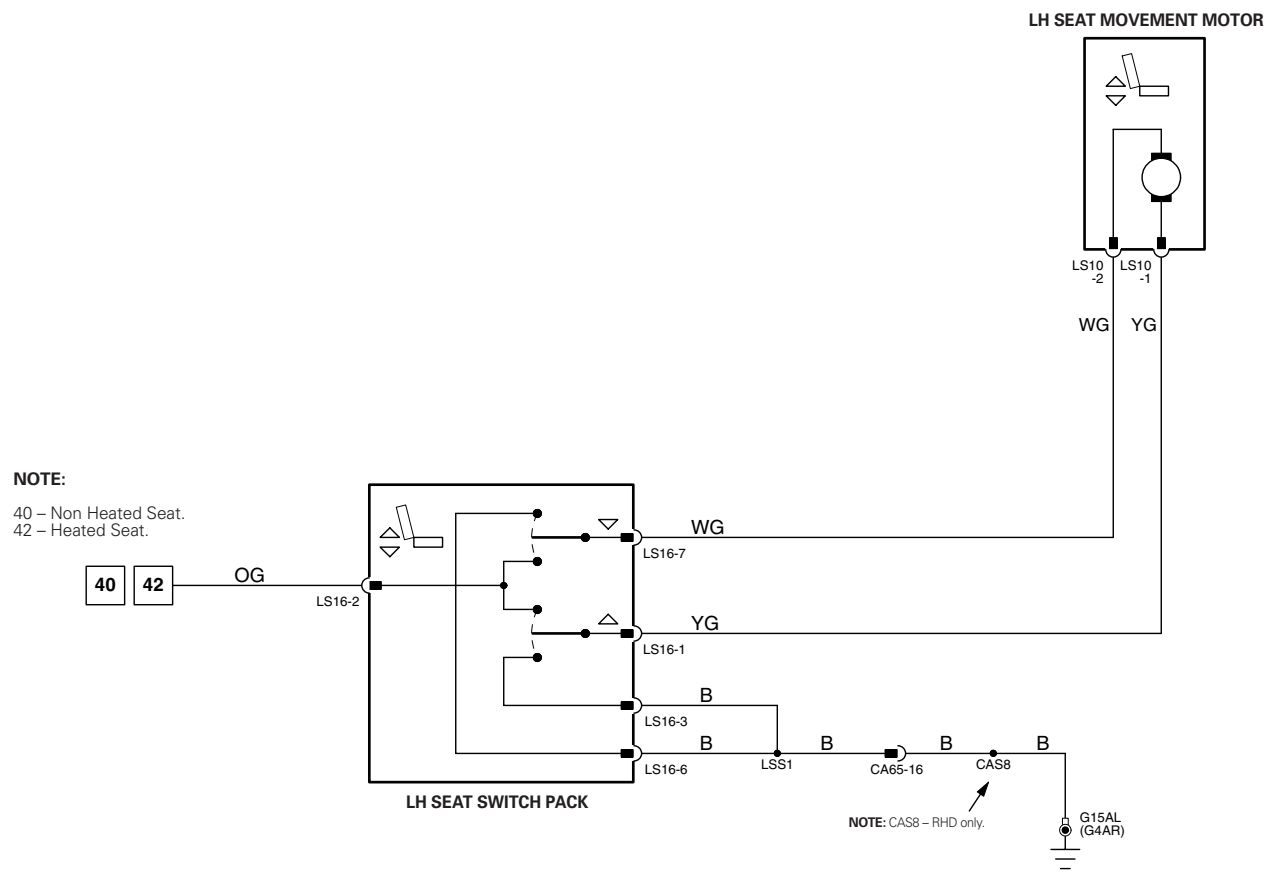

LH SEAT

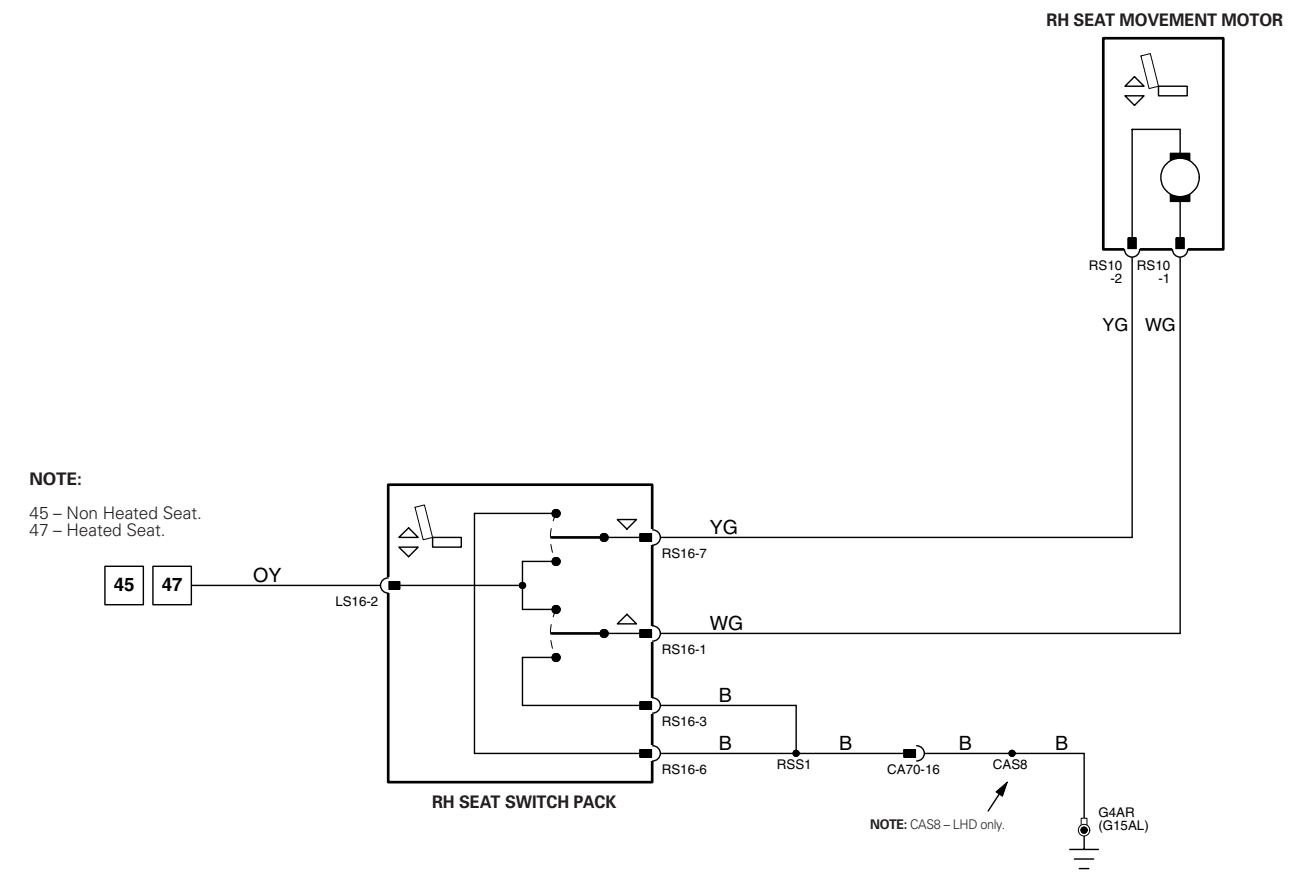

RH SEAT

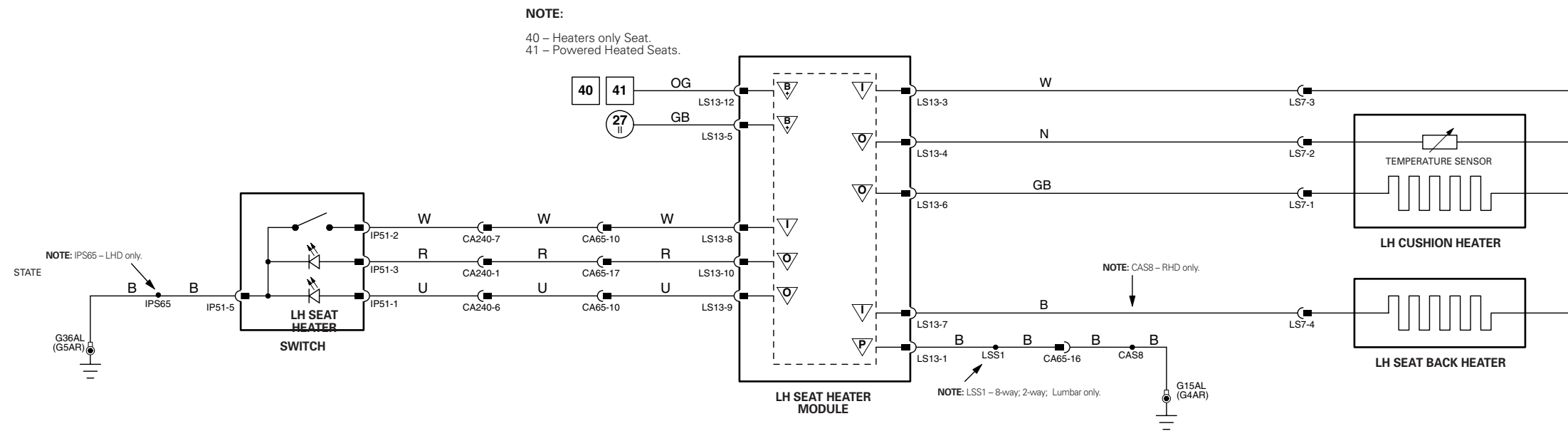

LH SEAT

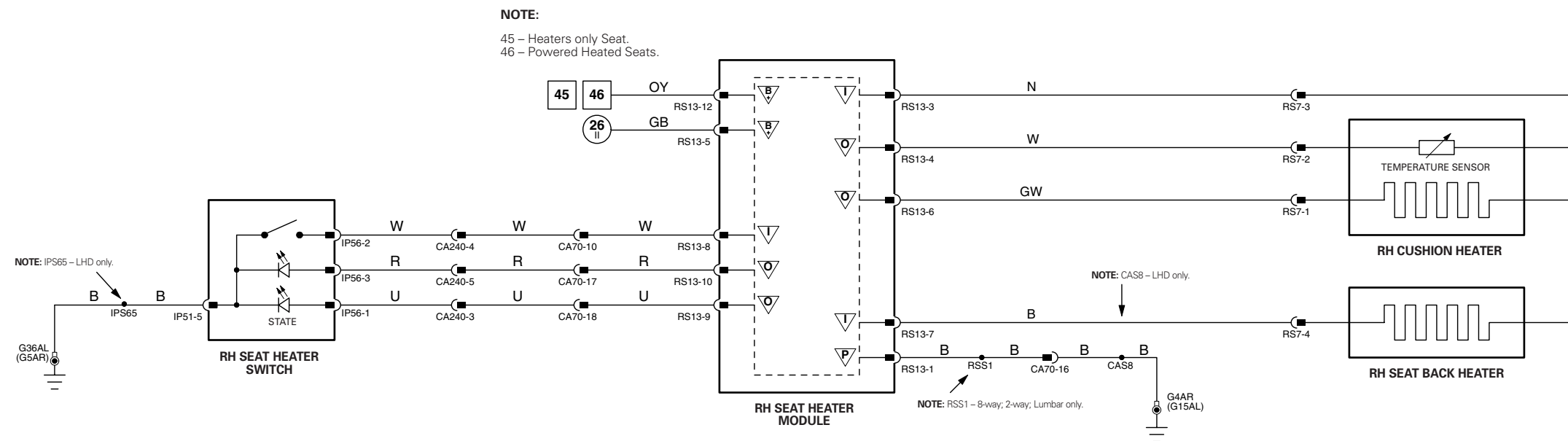

RH SEAT

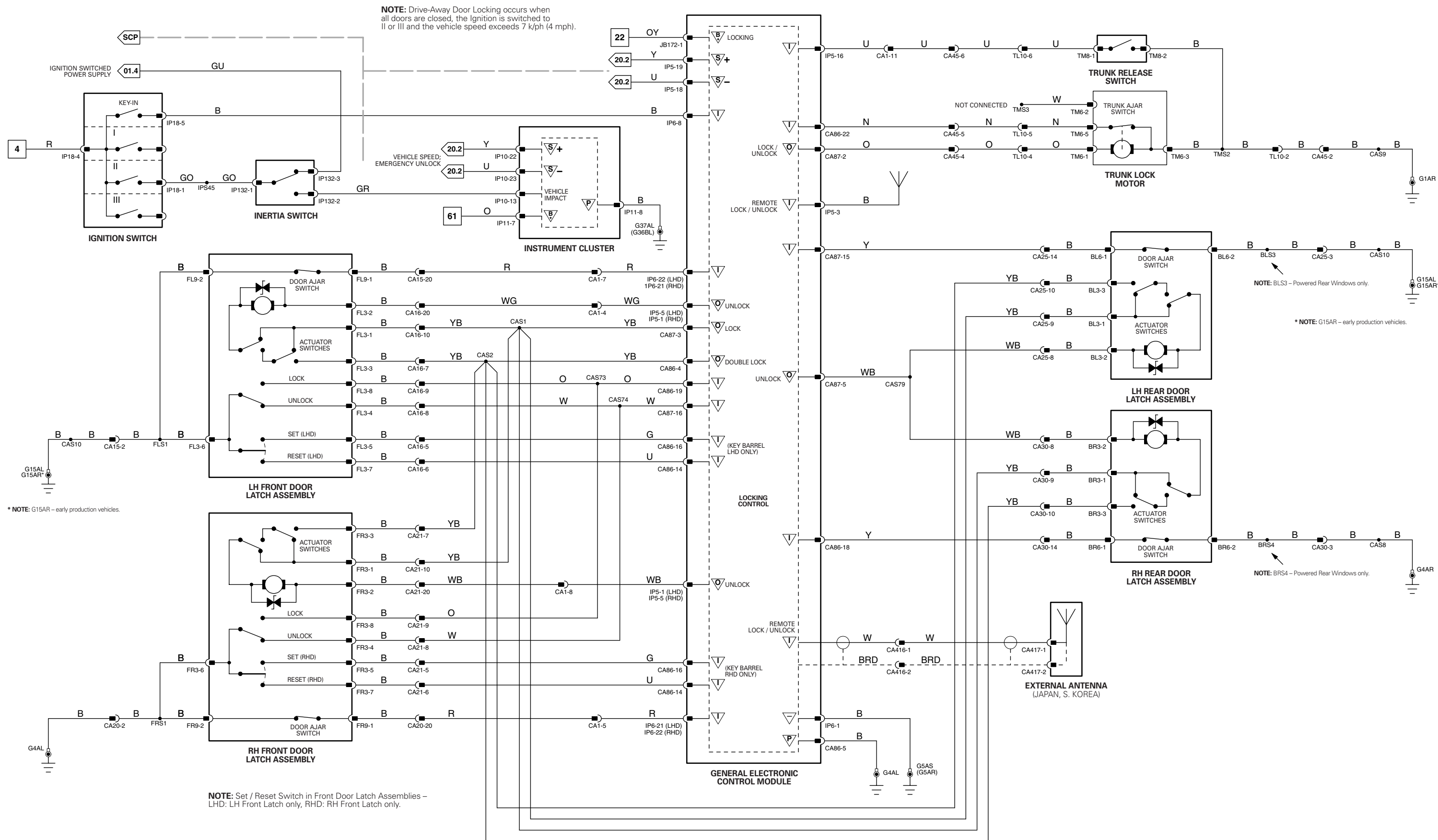



NOTE: Drive-Away Door Locking occurs when all doors are closed, the Ignition is switched to II or III and the vehicle speed exceeds 7 k/ph (4 mph).

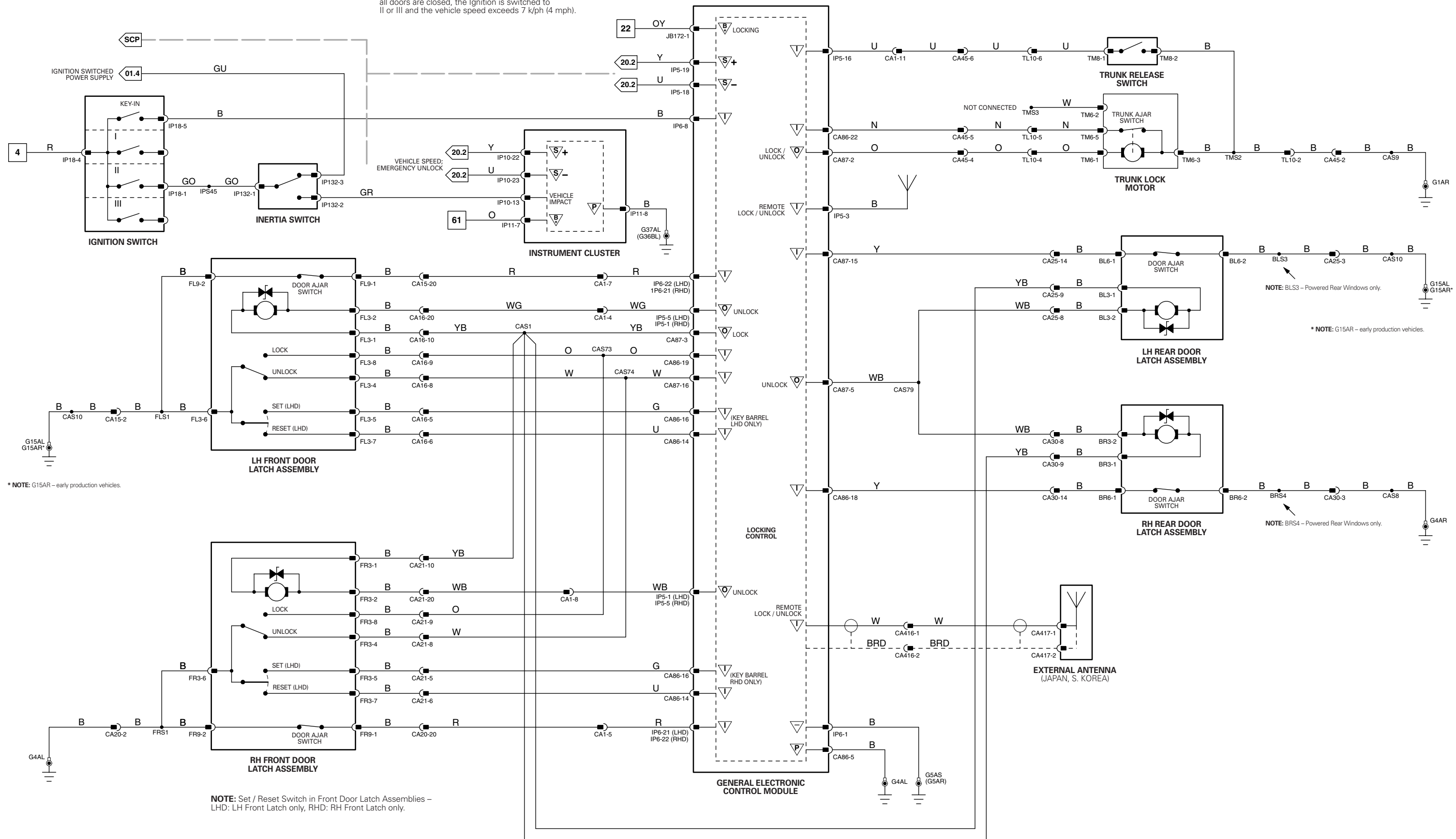

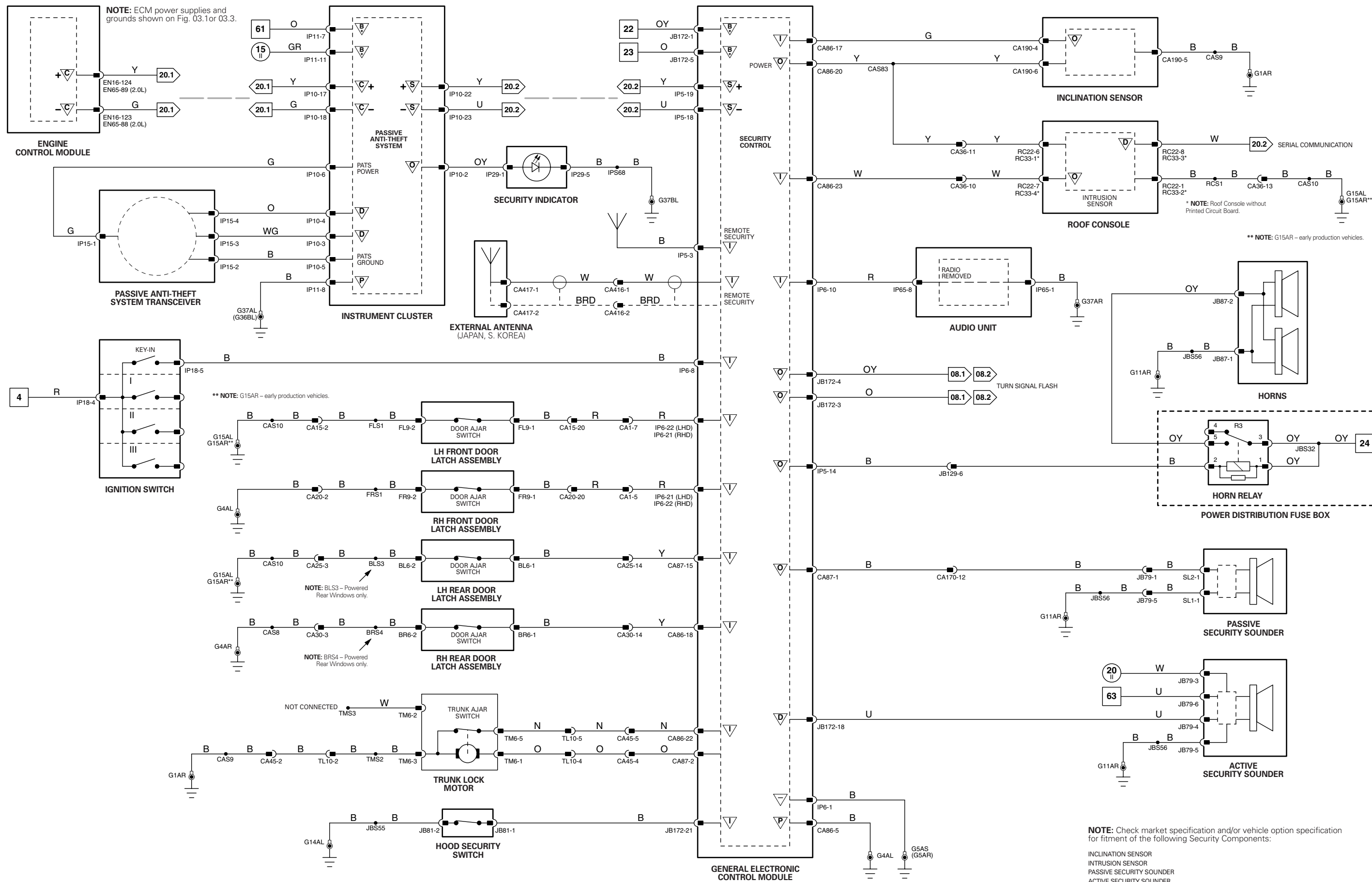

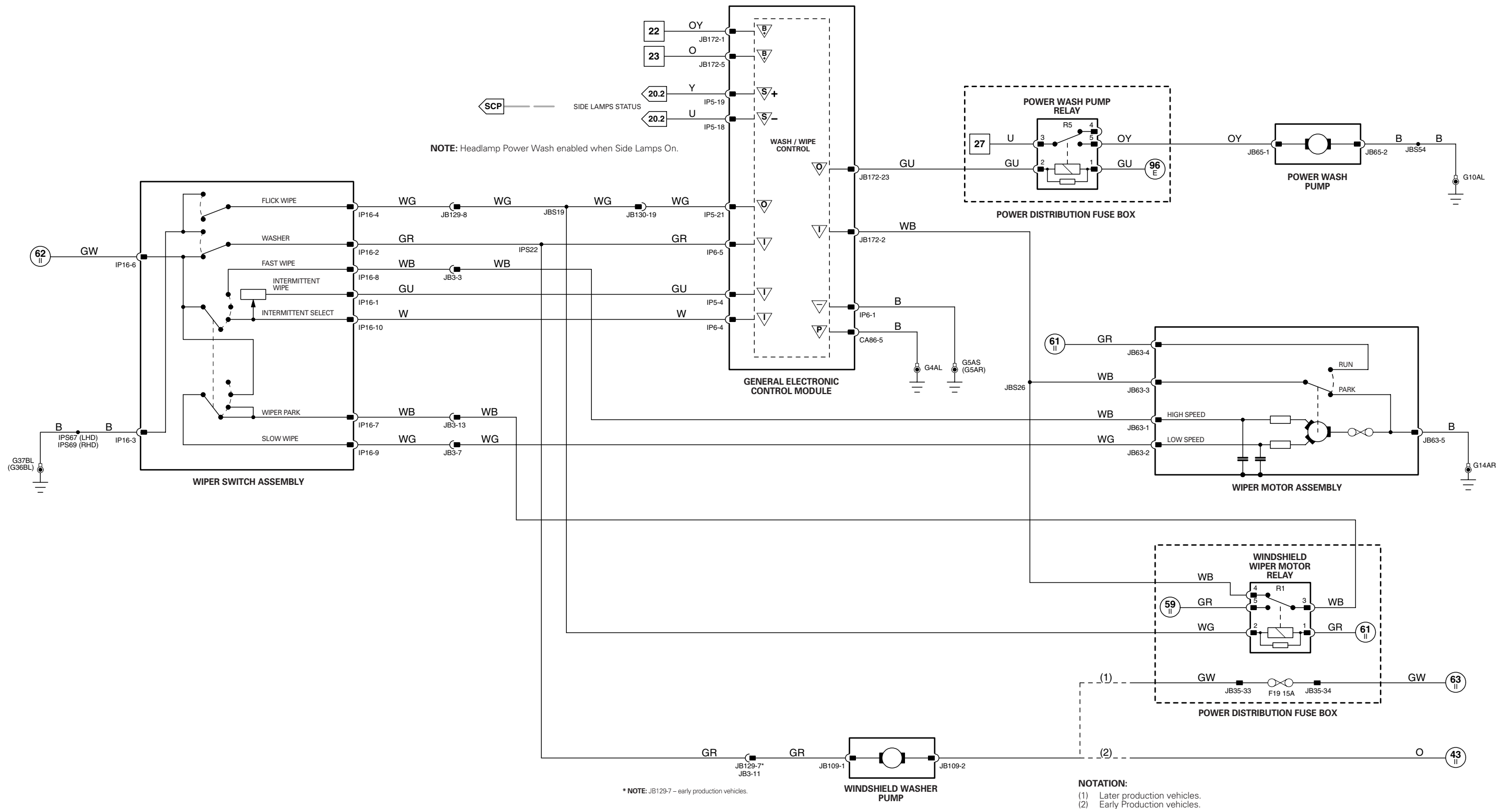

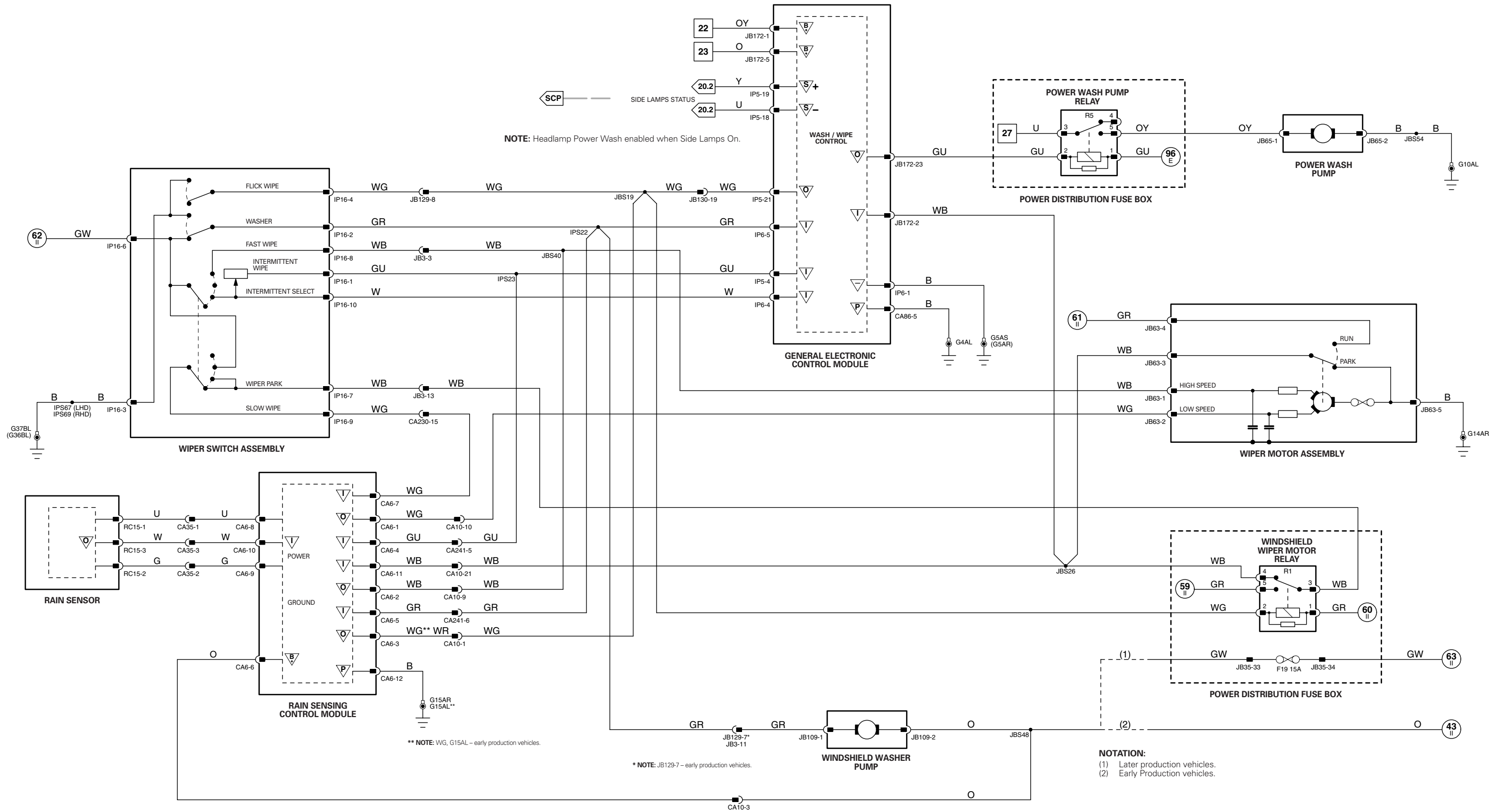



* NOTE: Remote Global Close - ROW vehicles only.

EXTERNAL ANTENNA (JAPAN, S. KOREA)

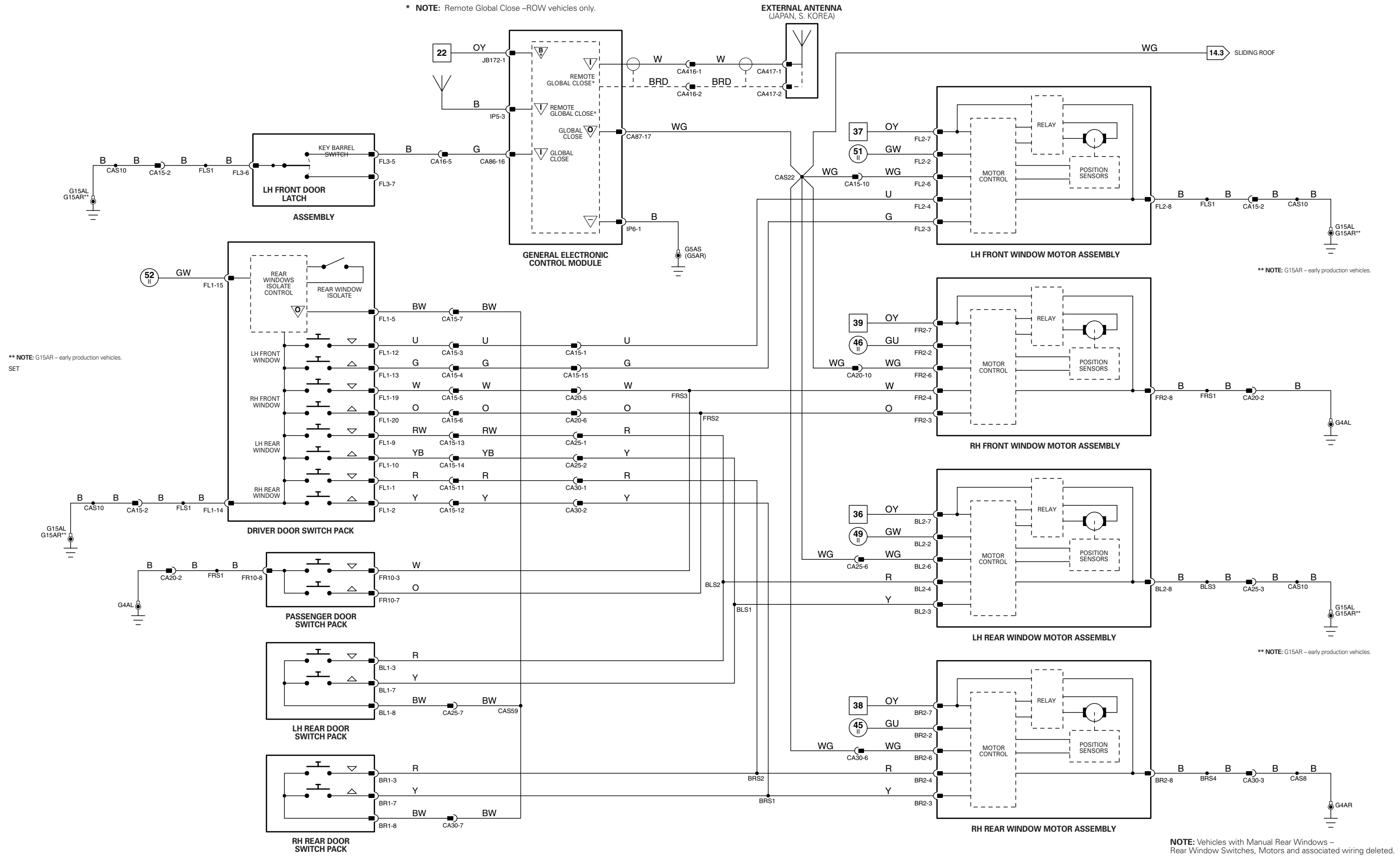

** NOTE: G15AR - early production vehicles. SET

** NOTE: G15AR - early production vehicles.

** NOTE: G15AR - early production vehicles.

NOTE: Vehicles with Manual Rear Windows - Rear Window Switches, Motors and associated wiring deleted.

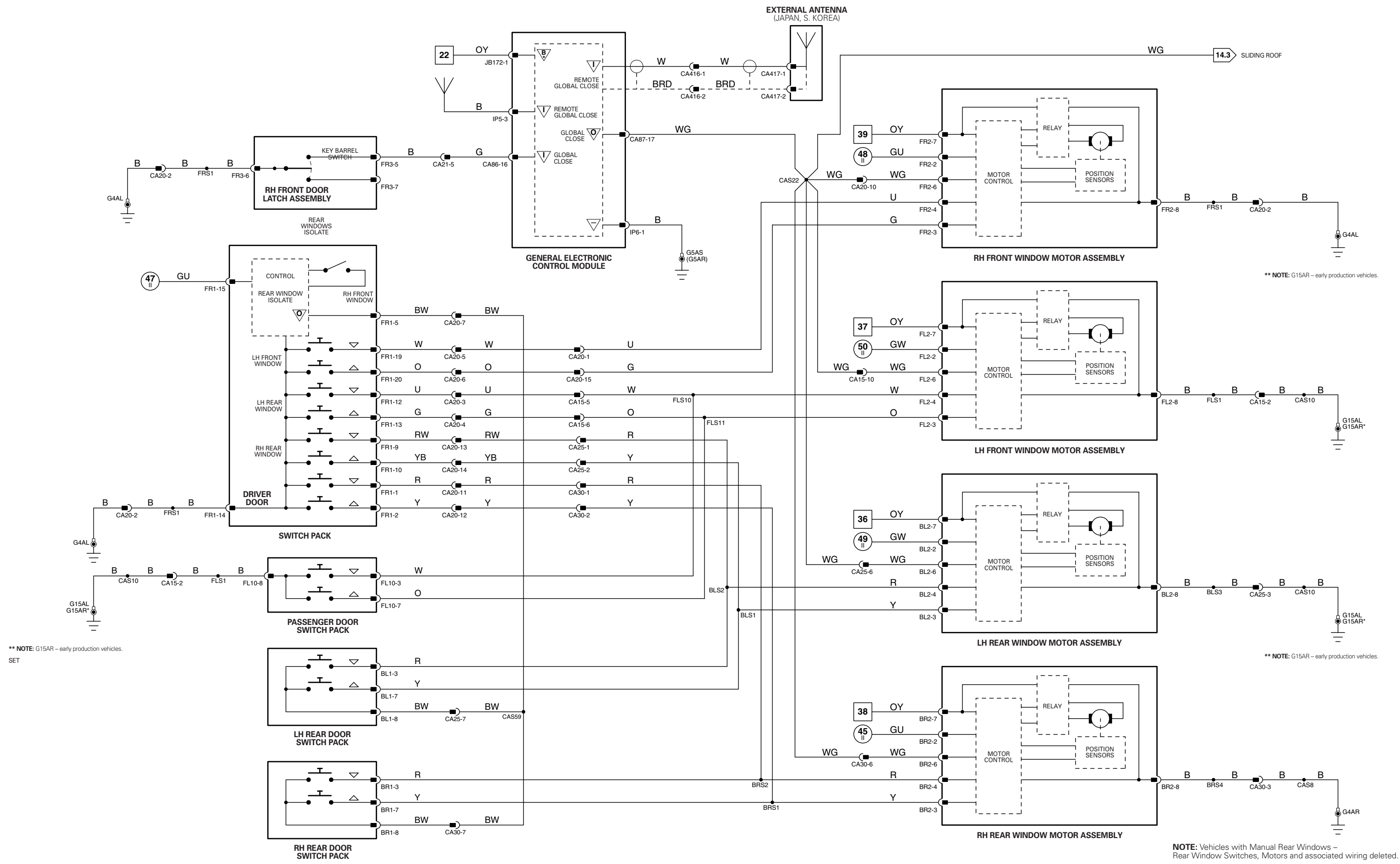

** NOTE: G15AR – early production vehicles. SET

** NOTE: G15AR – early production vehicles.

** NOTE: G15AR – early production vehicles.

NOTE: Vehicles with Manual Rear Windows – Rear Window Switches, Motors and associated wiring deleted.

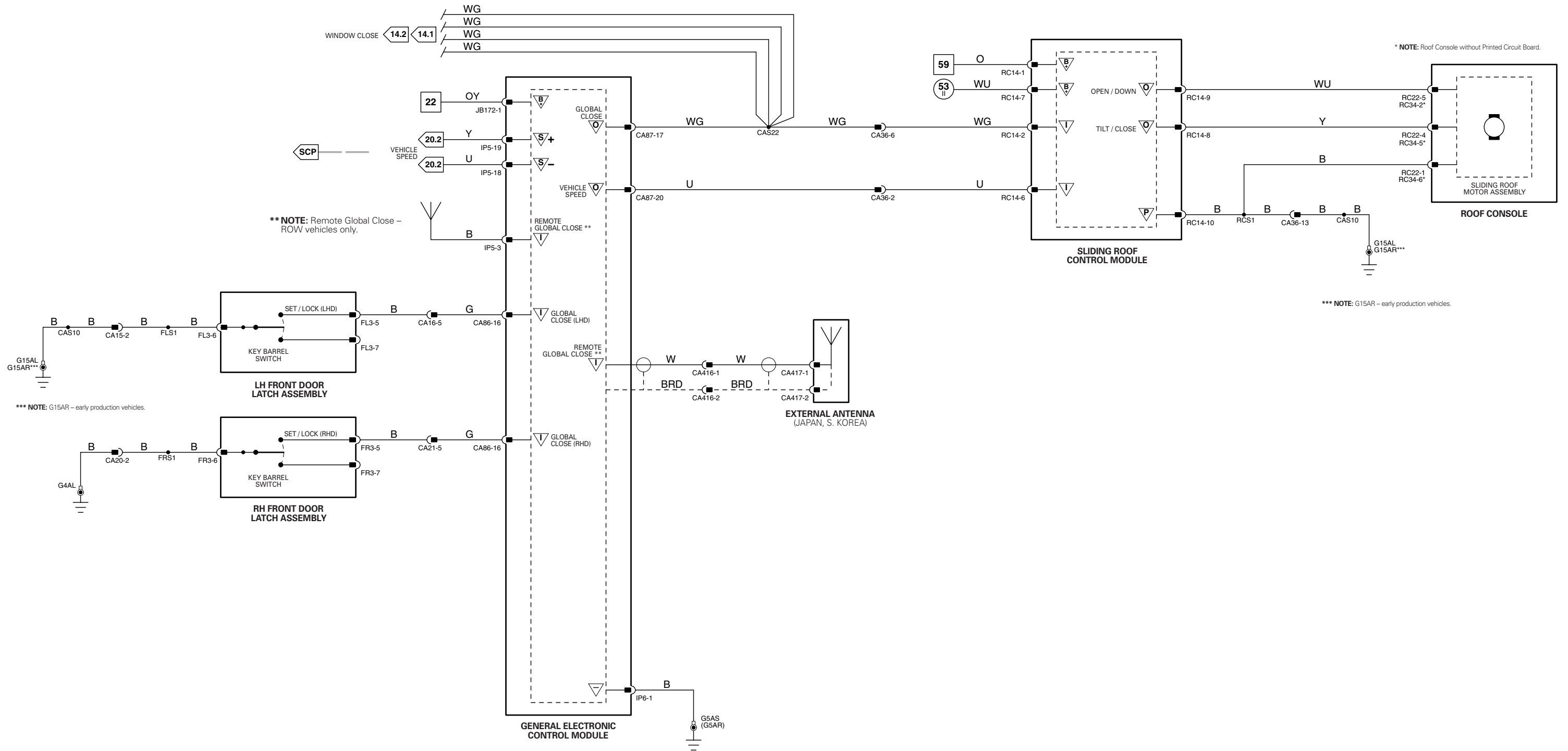

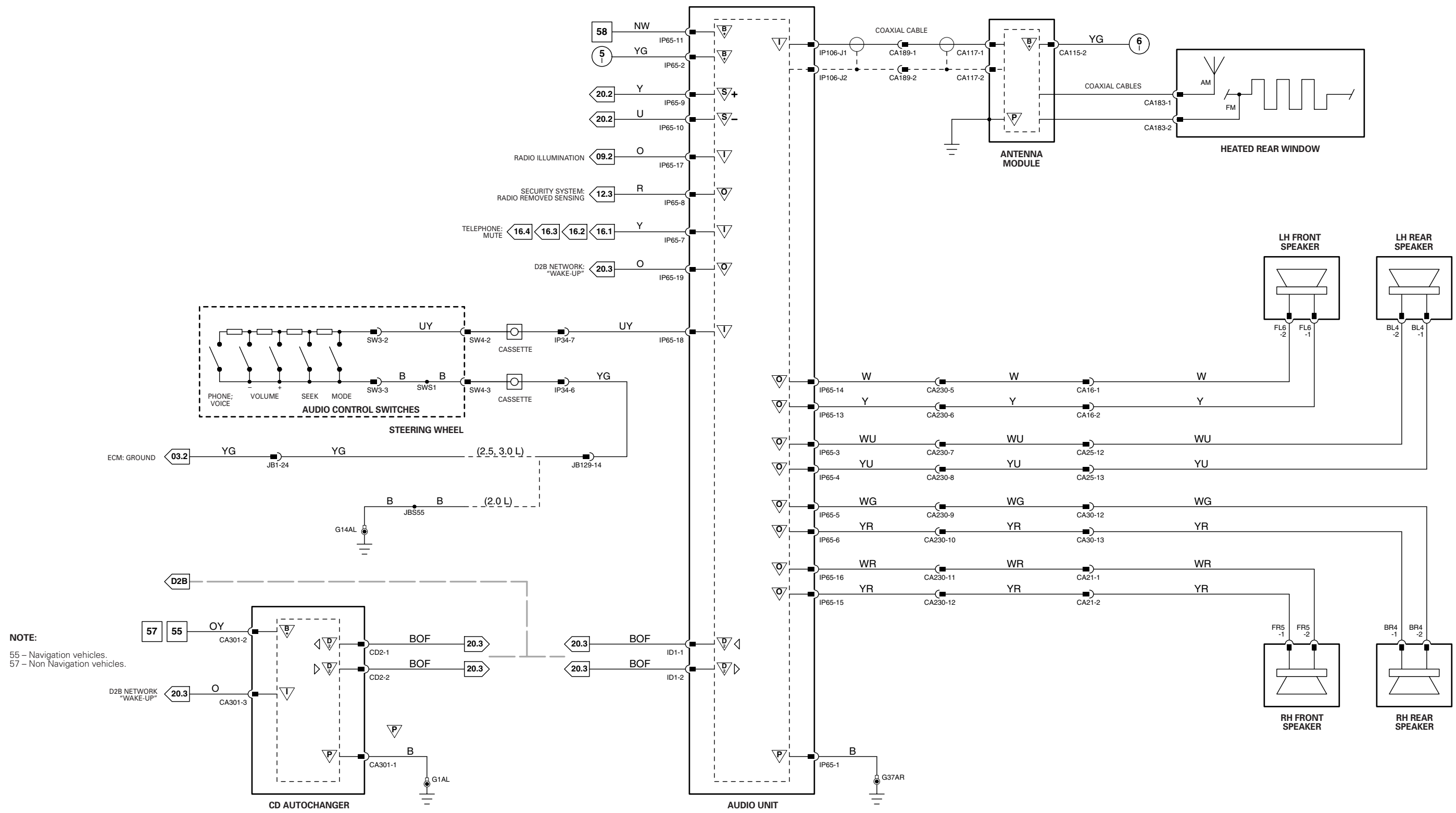

NOTE:
 55 - Navigation vehicles.
 57 - Non Navigation vehicles.

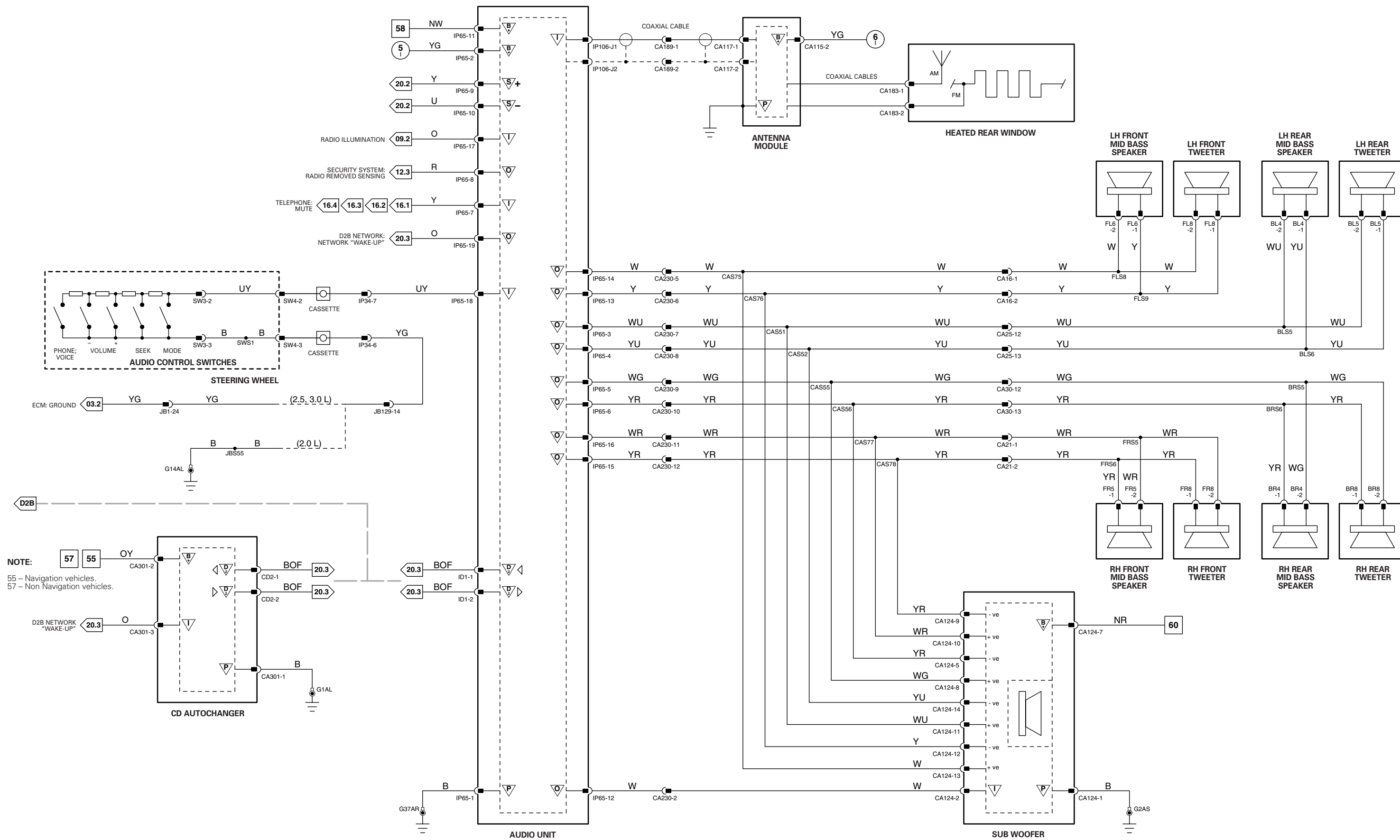

NOTE:
 55 – Navigation vehicles.
 57 – Non Navigation vehicles.

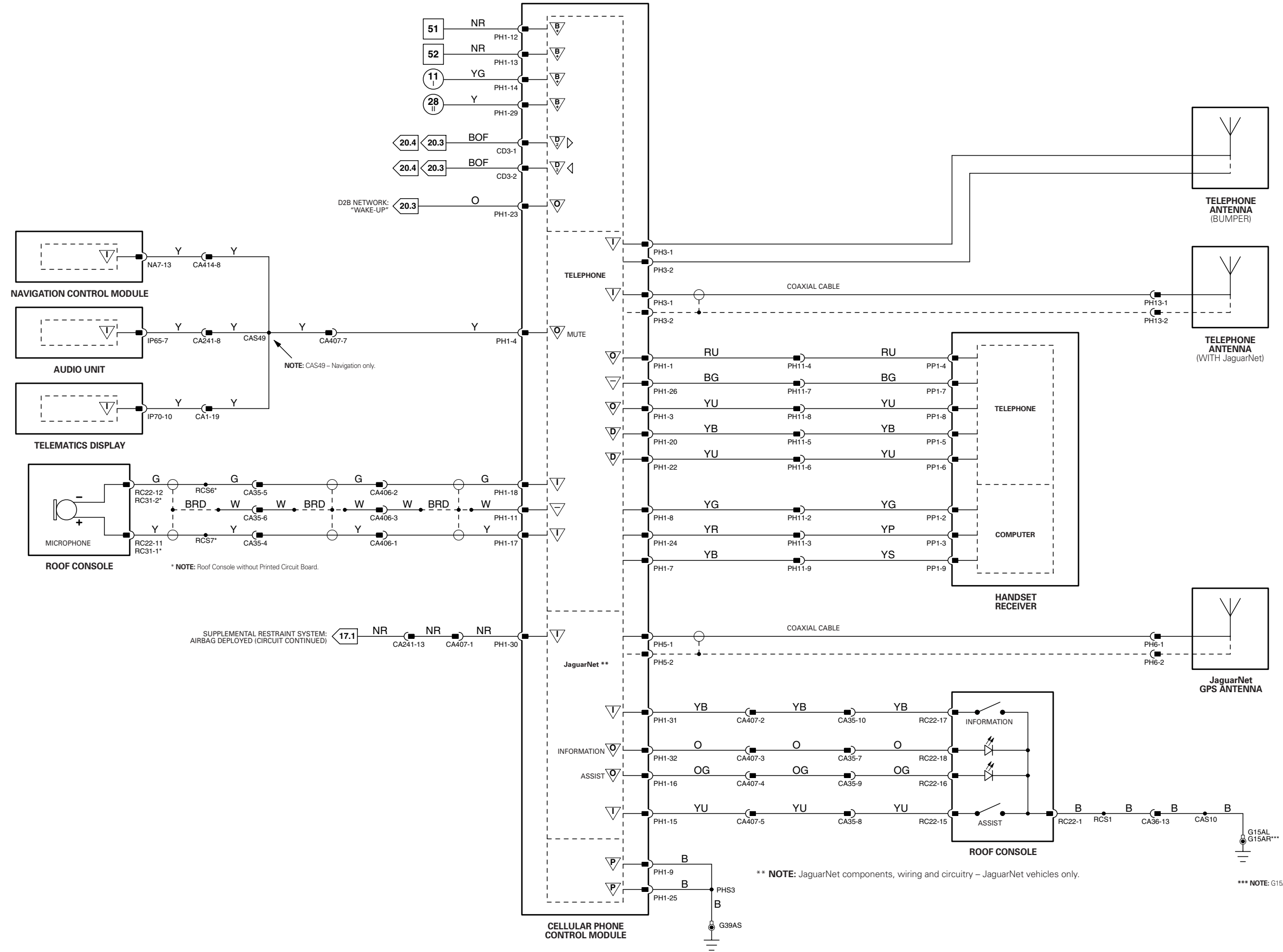

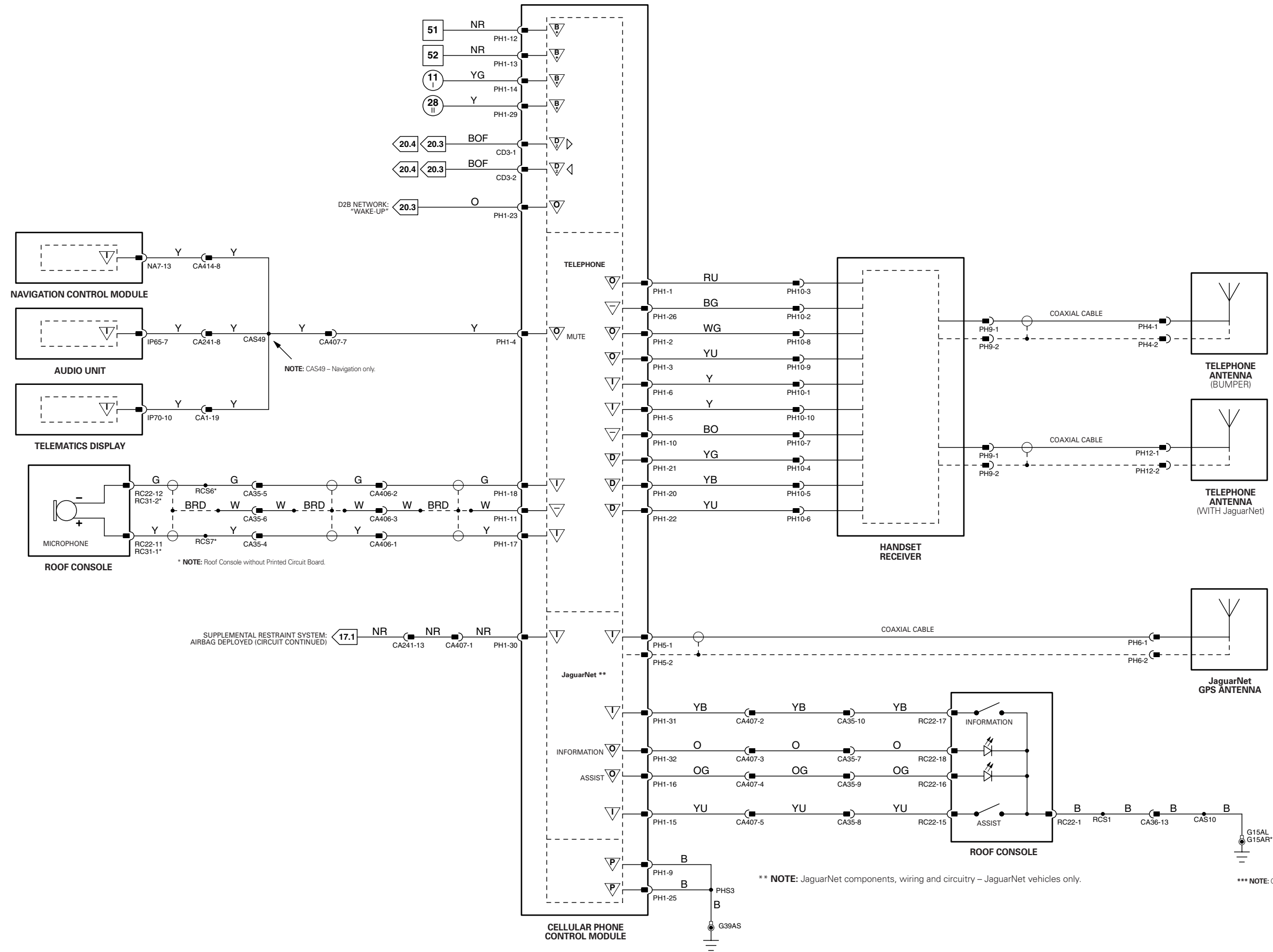

** NOTE: JaguarNet components, wiring and circuitry – JaguarNet vehicles only.

*** NOTE: G15AR – early production vehicles.

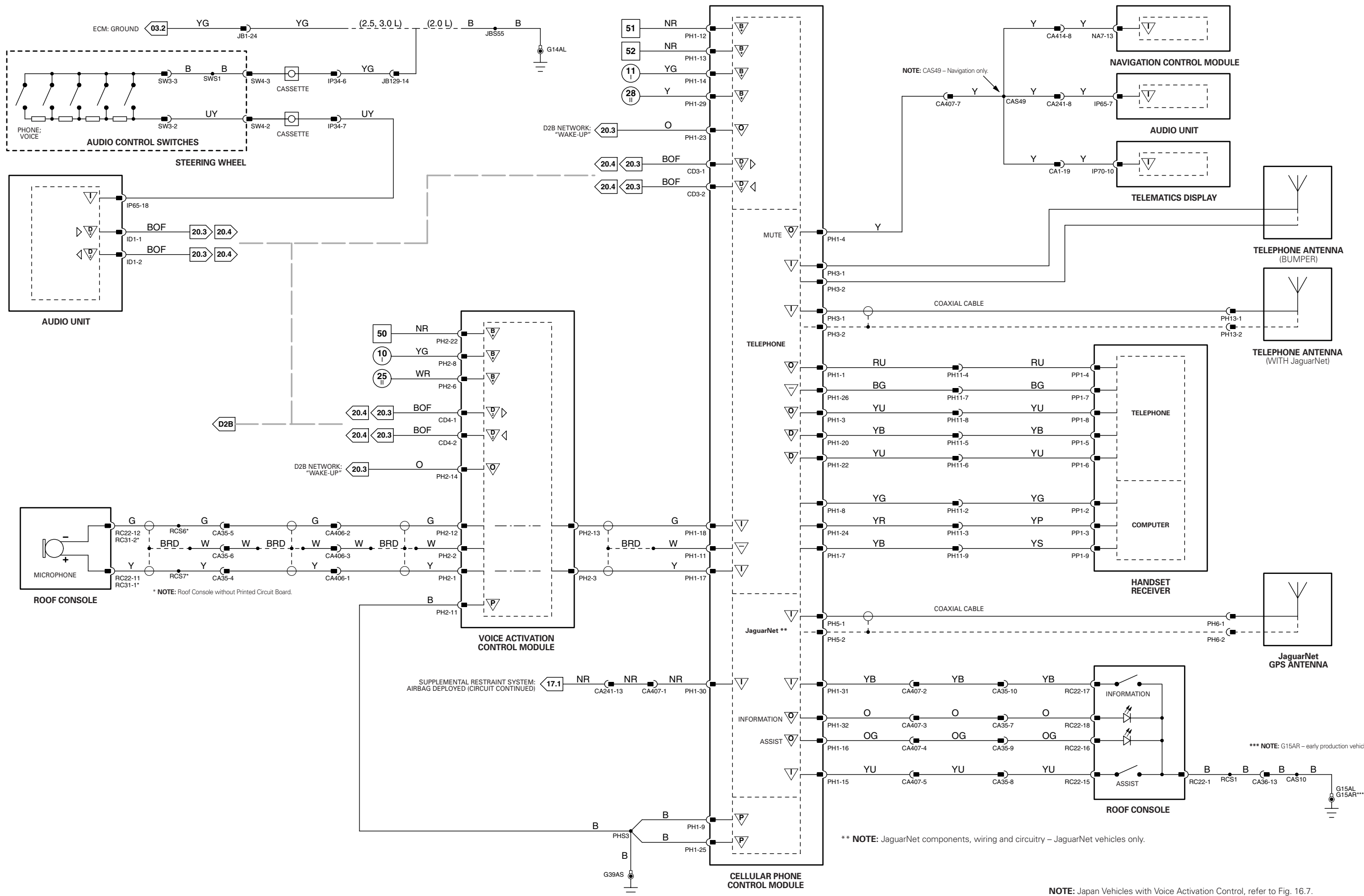

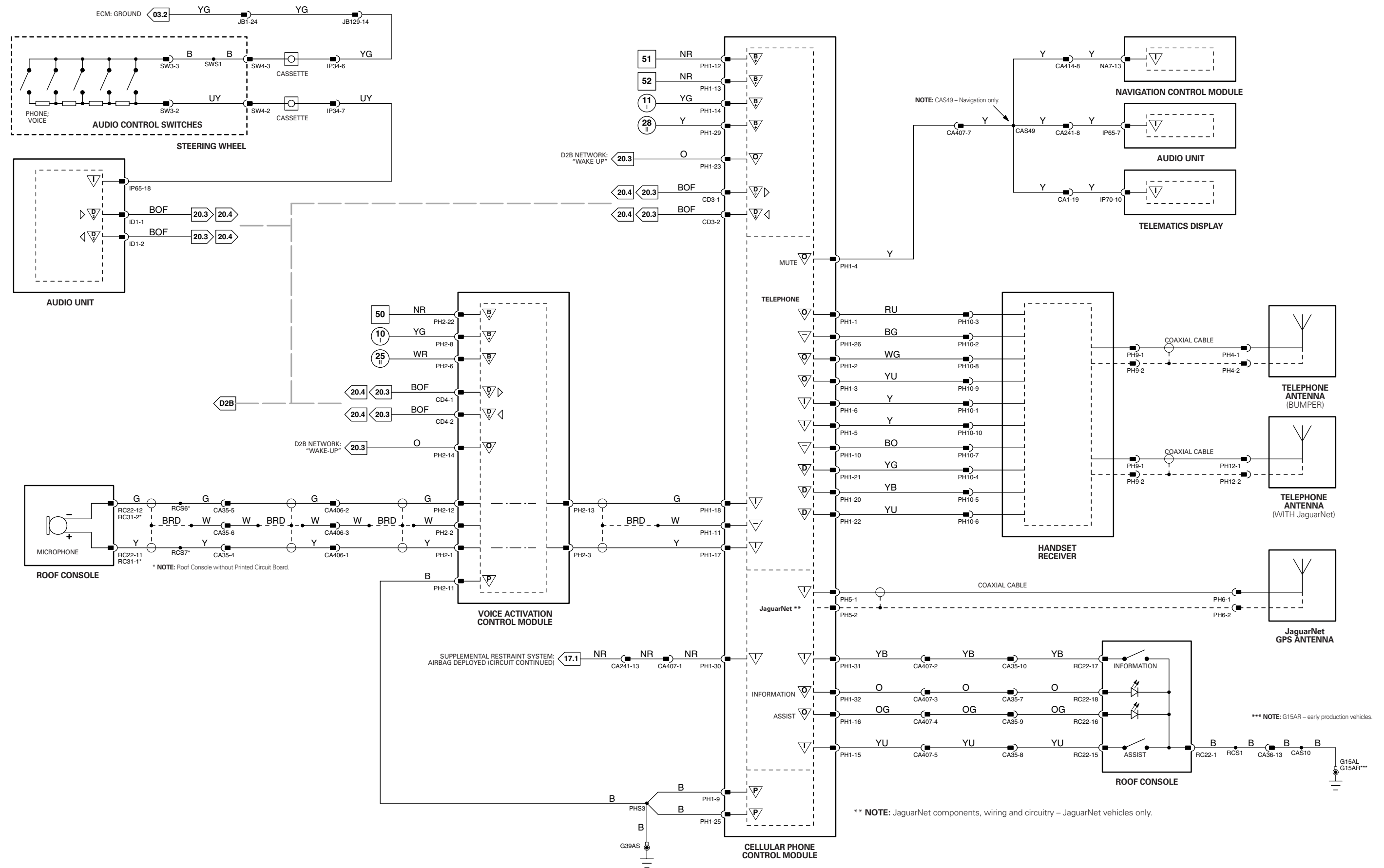

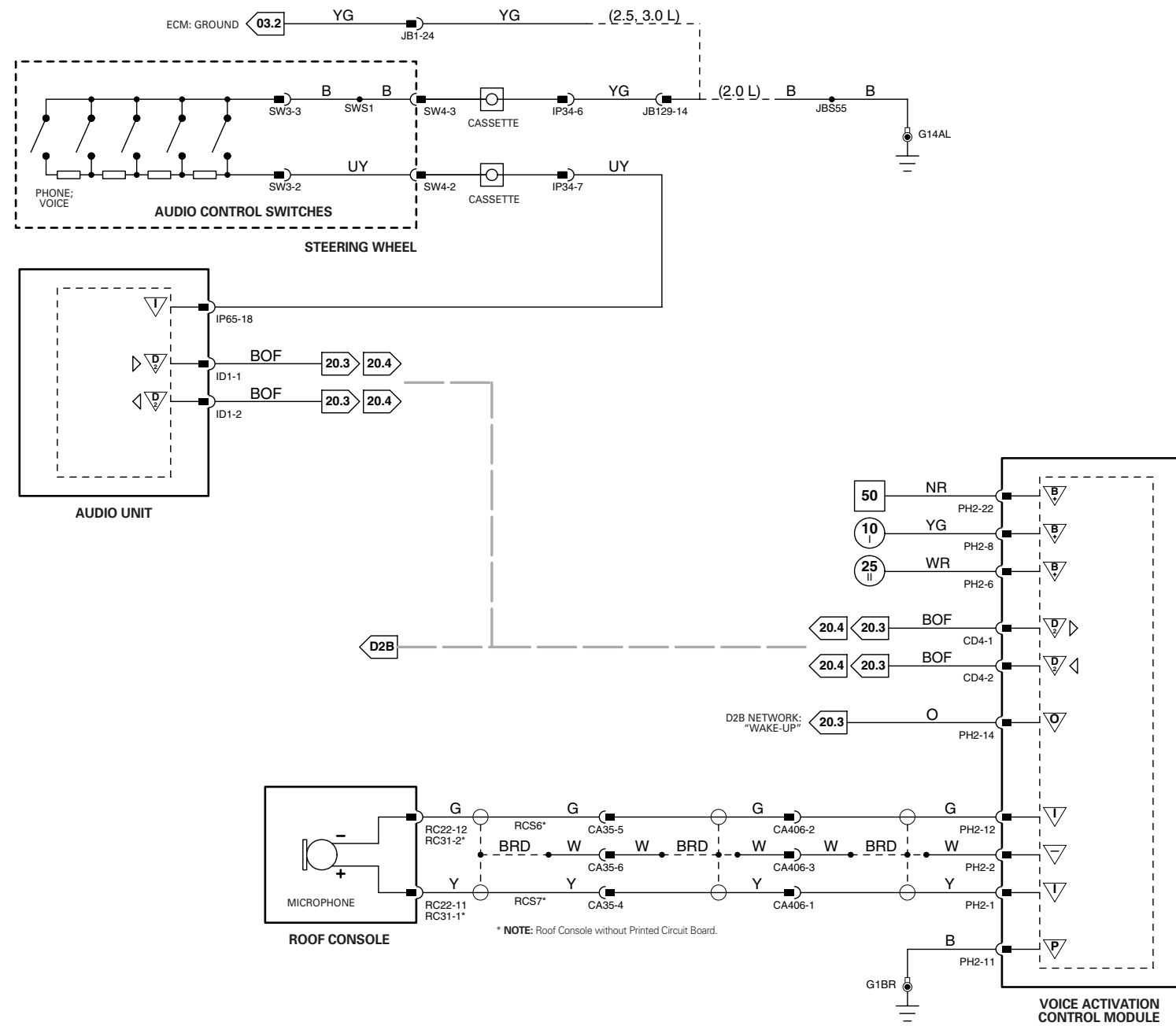

NOTE: Japan Vehicles with Voice Activation Control, refer to Fig. 16.7.



NOTE:

54 – Vehicles with Navigation and CD Autochanger.
56 – Vehicles with Navigation only.

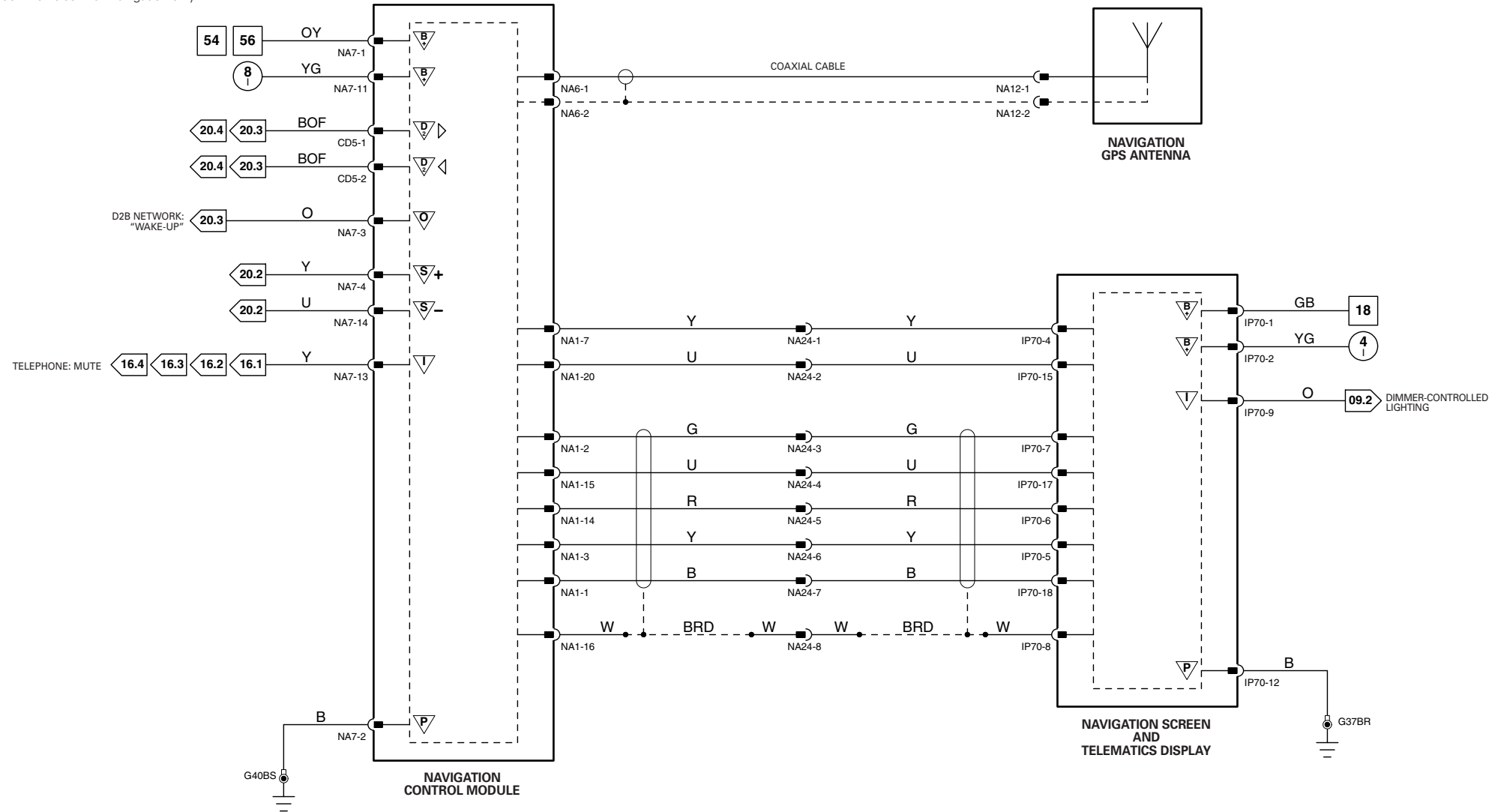



NOTE:

54 – Vehicles with Navigation and CD Autochanger.
56 – Vehicles with Navigation only.

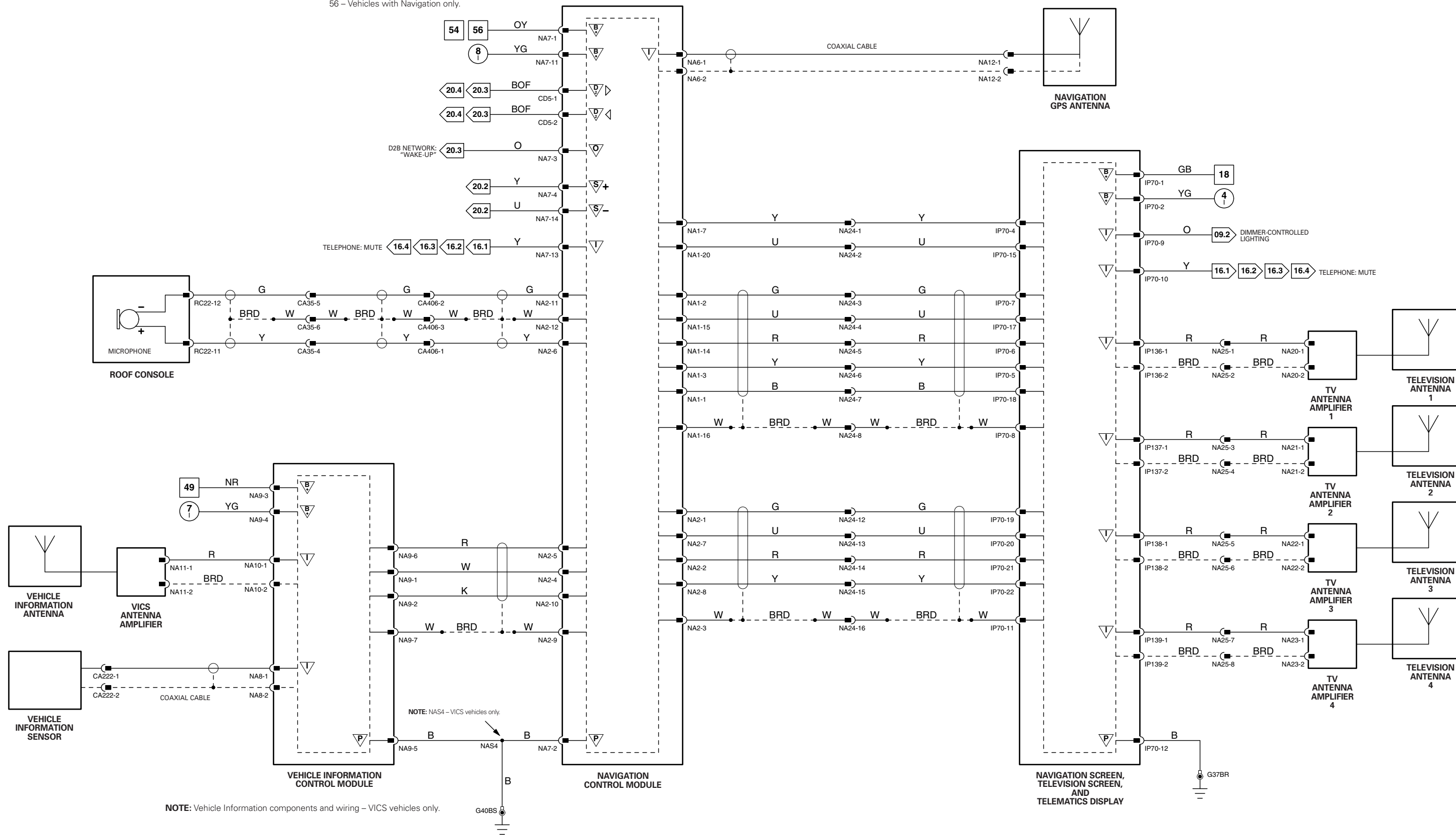

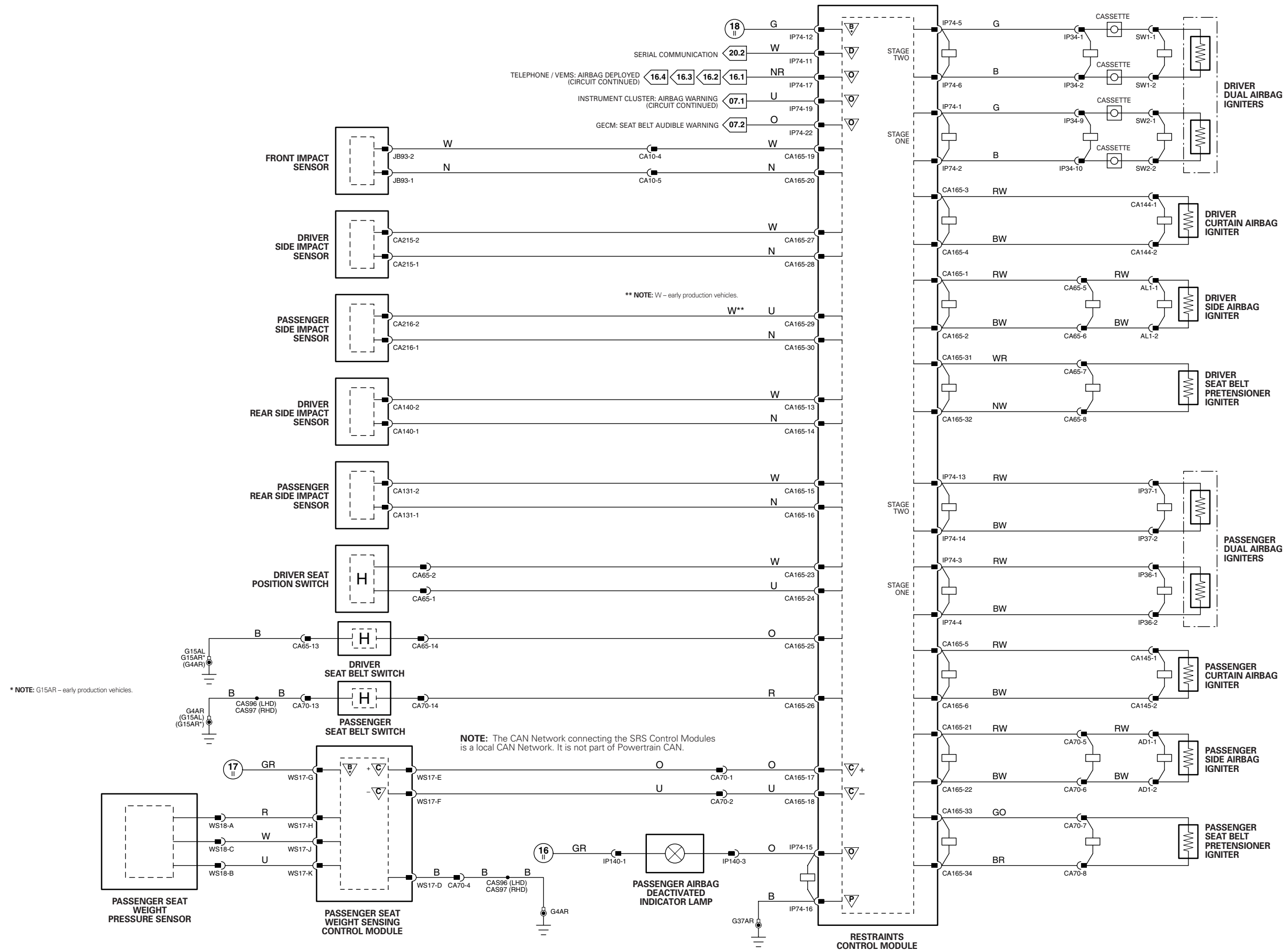

* NOTE: G15AR - early production vehicles.

NOTE: The CAN Network connecting the SRS Control Modules is a local CAN Network. It is not part of Powertrain CAN.

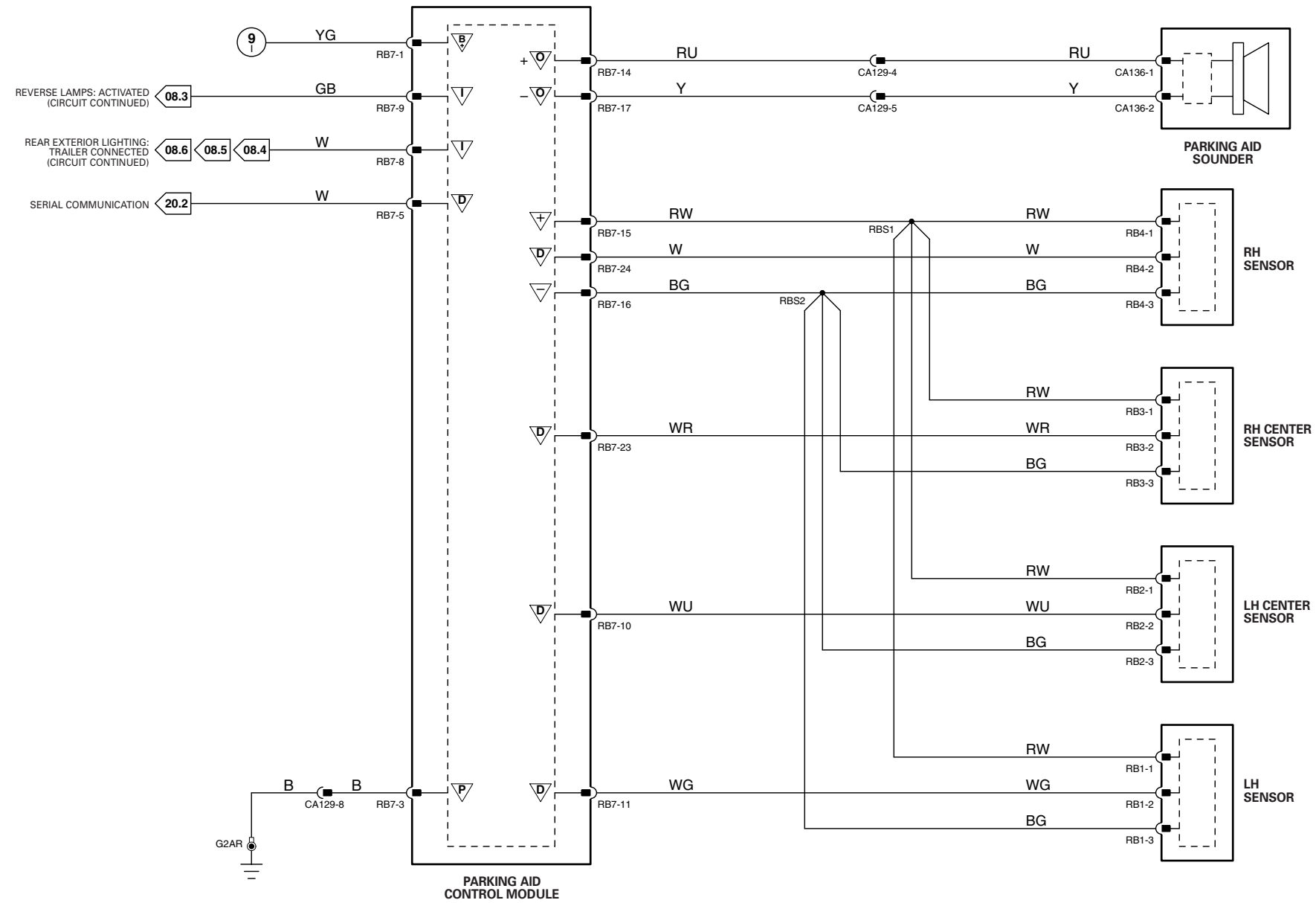

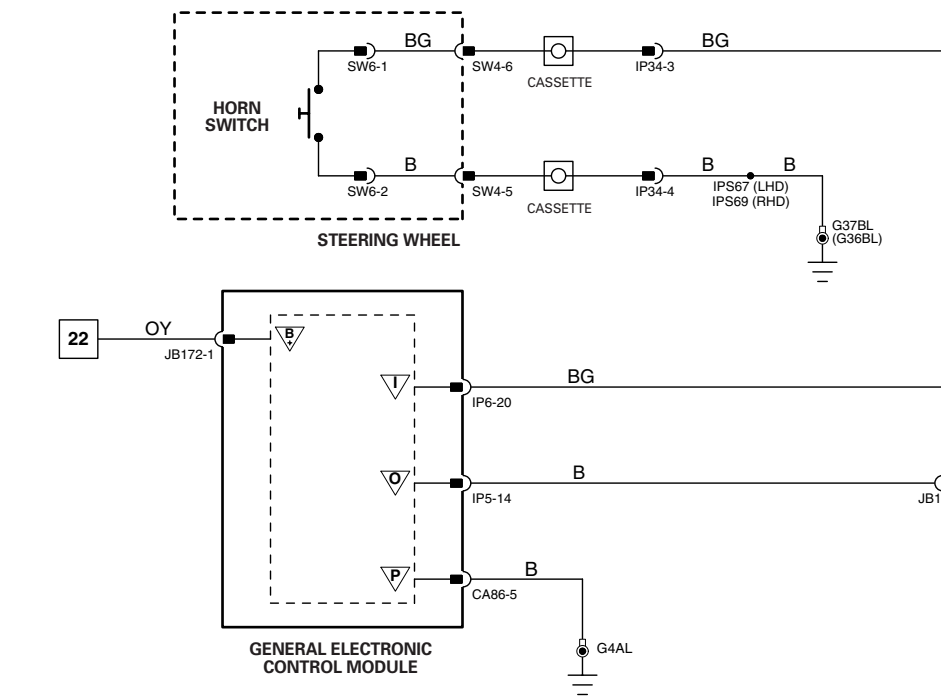

HORN

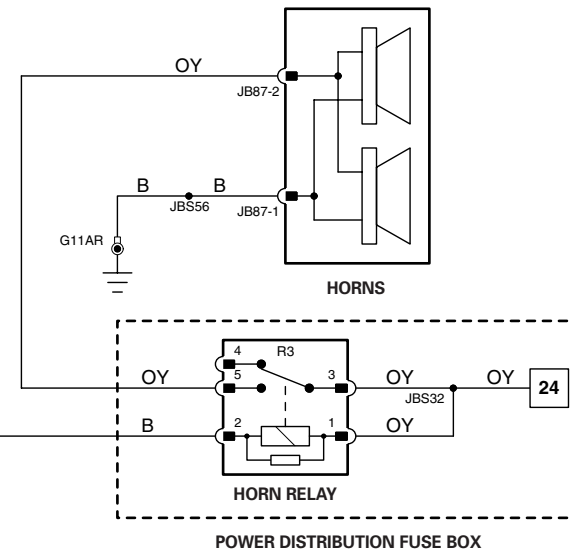

CIGAR LIGHTER

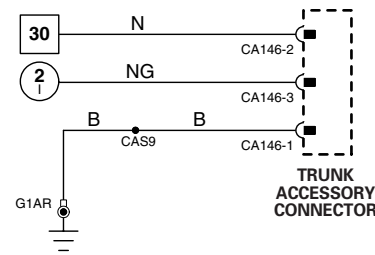
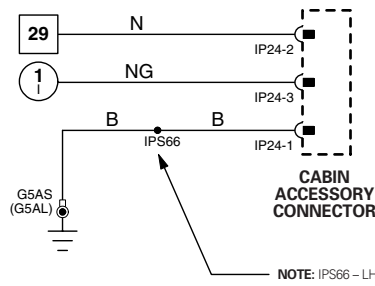
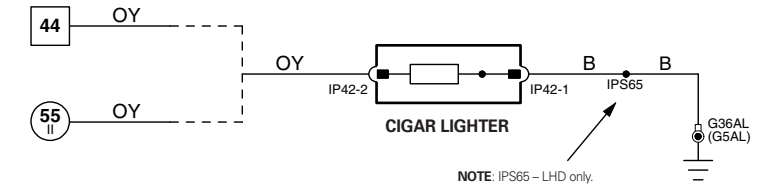

ACCESSORY CONNECTORS

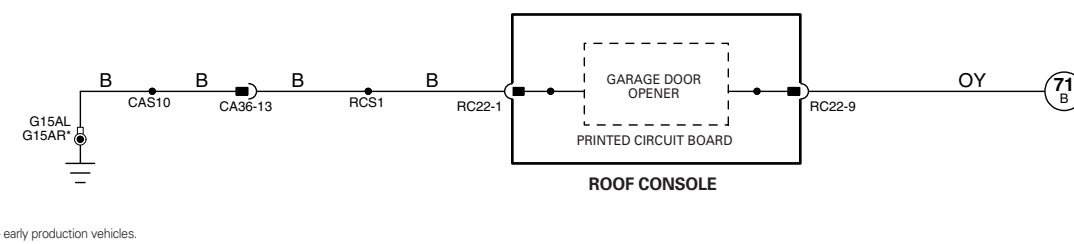

GARAGE DOOR OPENER

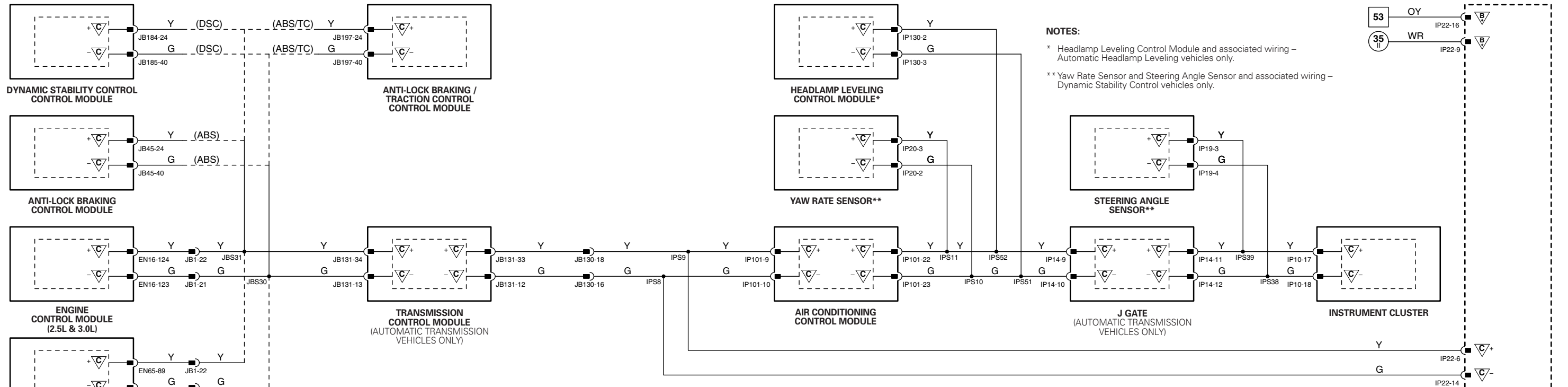

CONTROLLER AREA NETWORK: LHD

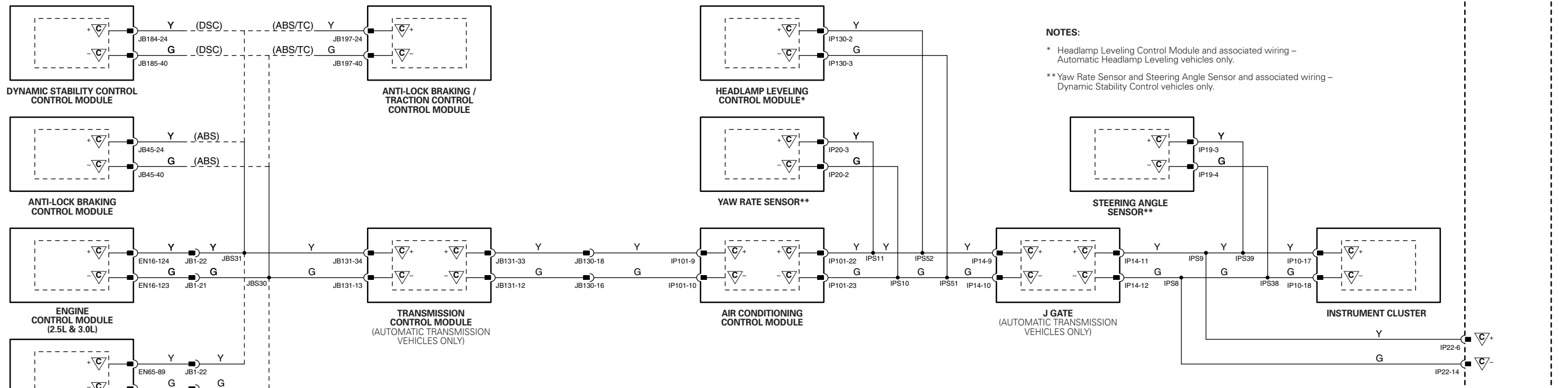

CONTROLLER AREA NETWORK: RHD

NOTES:

* Headlamp Leveling Control Module and associated wiring – Automatic Headlamp Leveling vehicles only.

** Yaw Rate Sensor and Steering Angle Sensor and associated wiring – Dynamic Stability Control vehicles only.

NOTES:

* Headlamp Leveling Control Module and associated wiring – Automatic Headlamp Leveling vehicles only.

** Yaw Rate Sensor and Steering Angle Sensor and associated wiring – Dynamic Stability Control vehicles only.

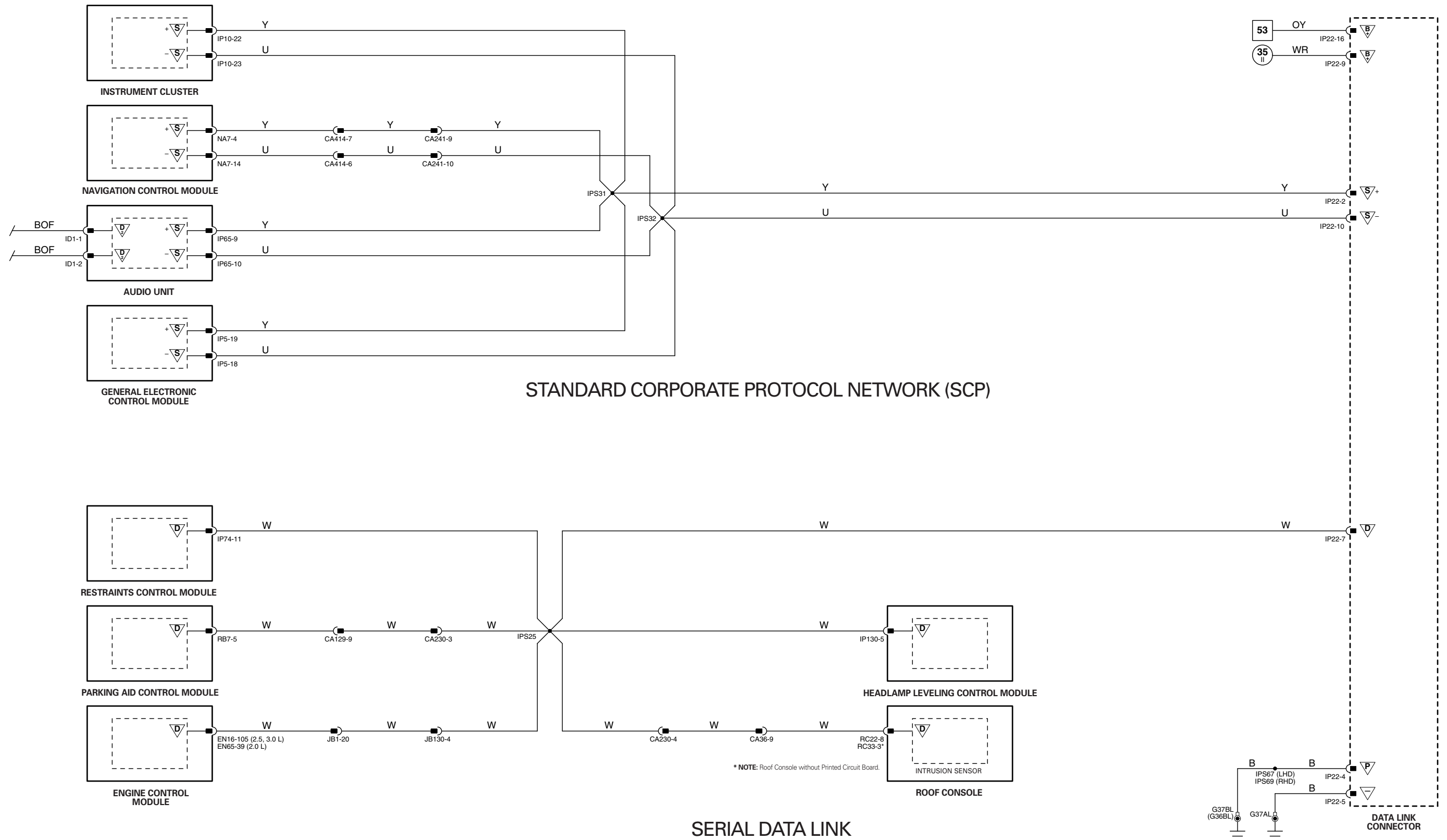

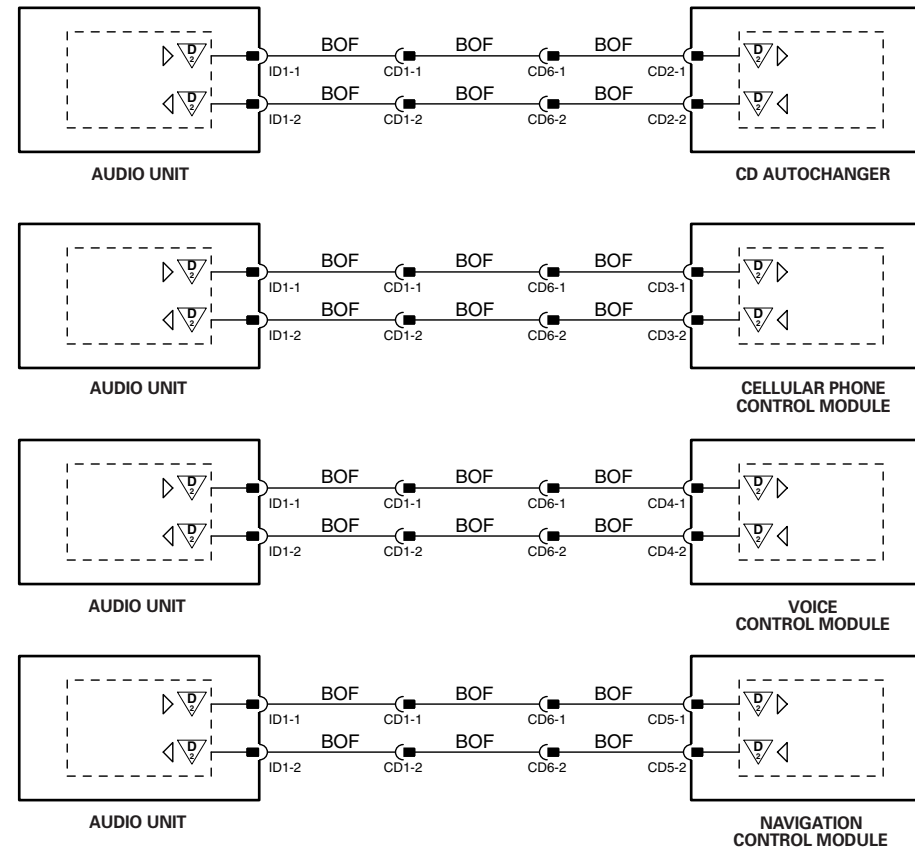
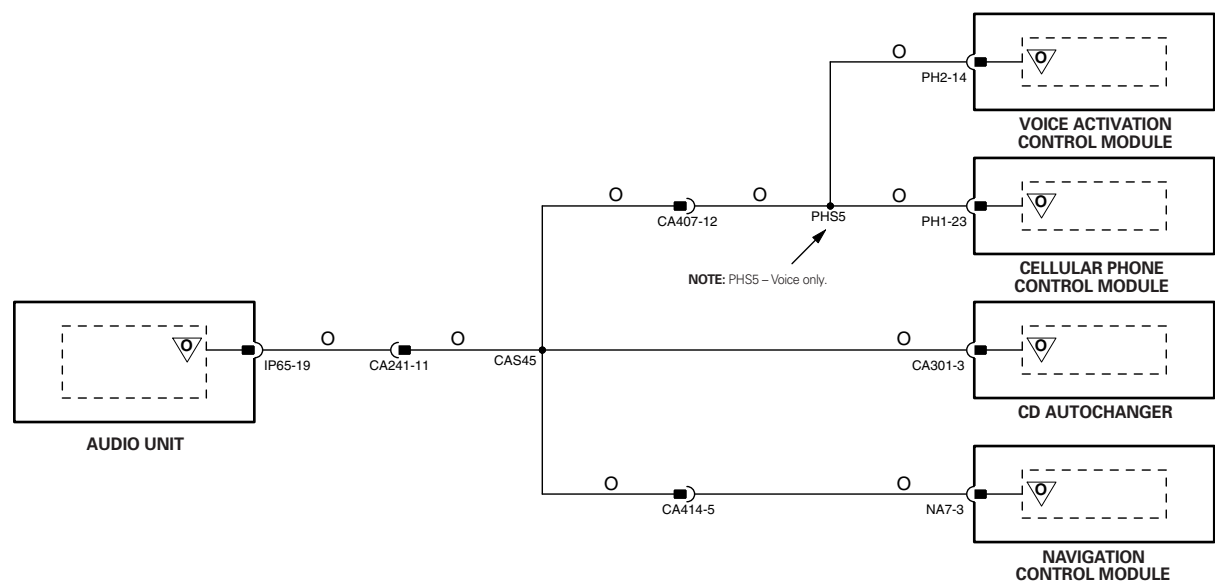

D2B NETWORK "WAKE-UP"

TWO-MODULE NETWORKS

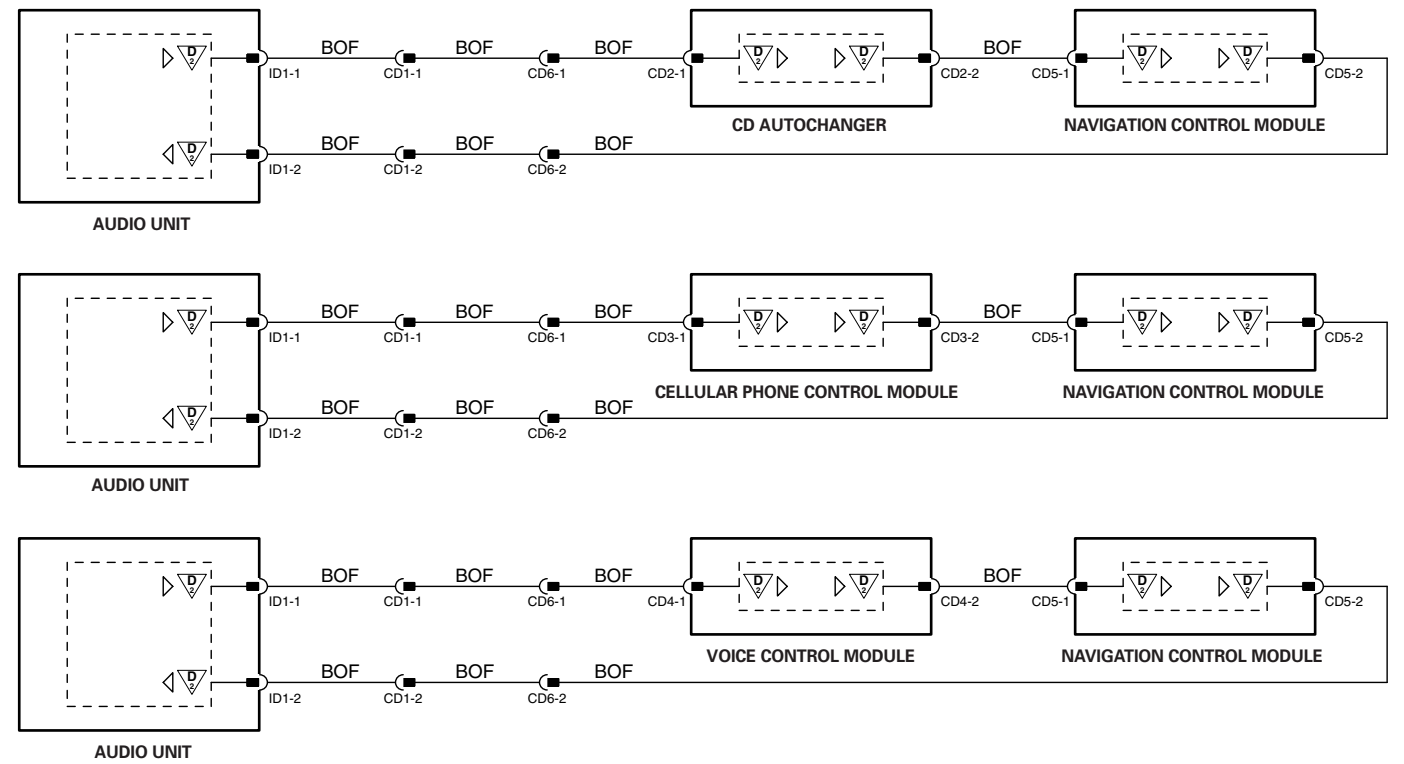
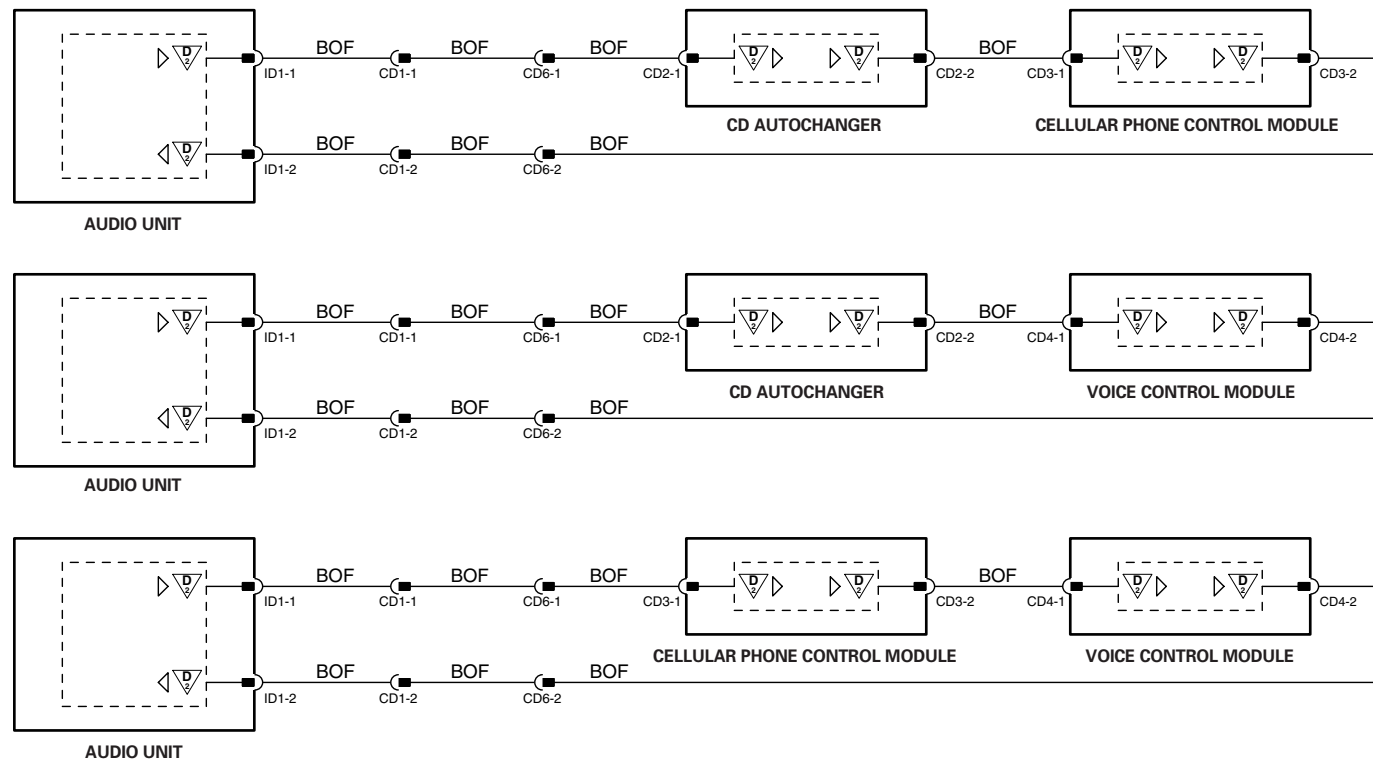

THREE-MODULE NETWORKS

NOTE: Figs. 20.3 and 20.4 show all possible combinations of D2B Networks.

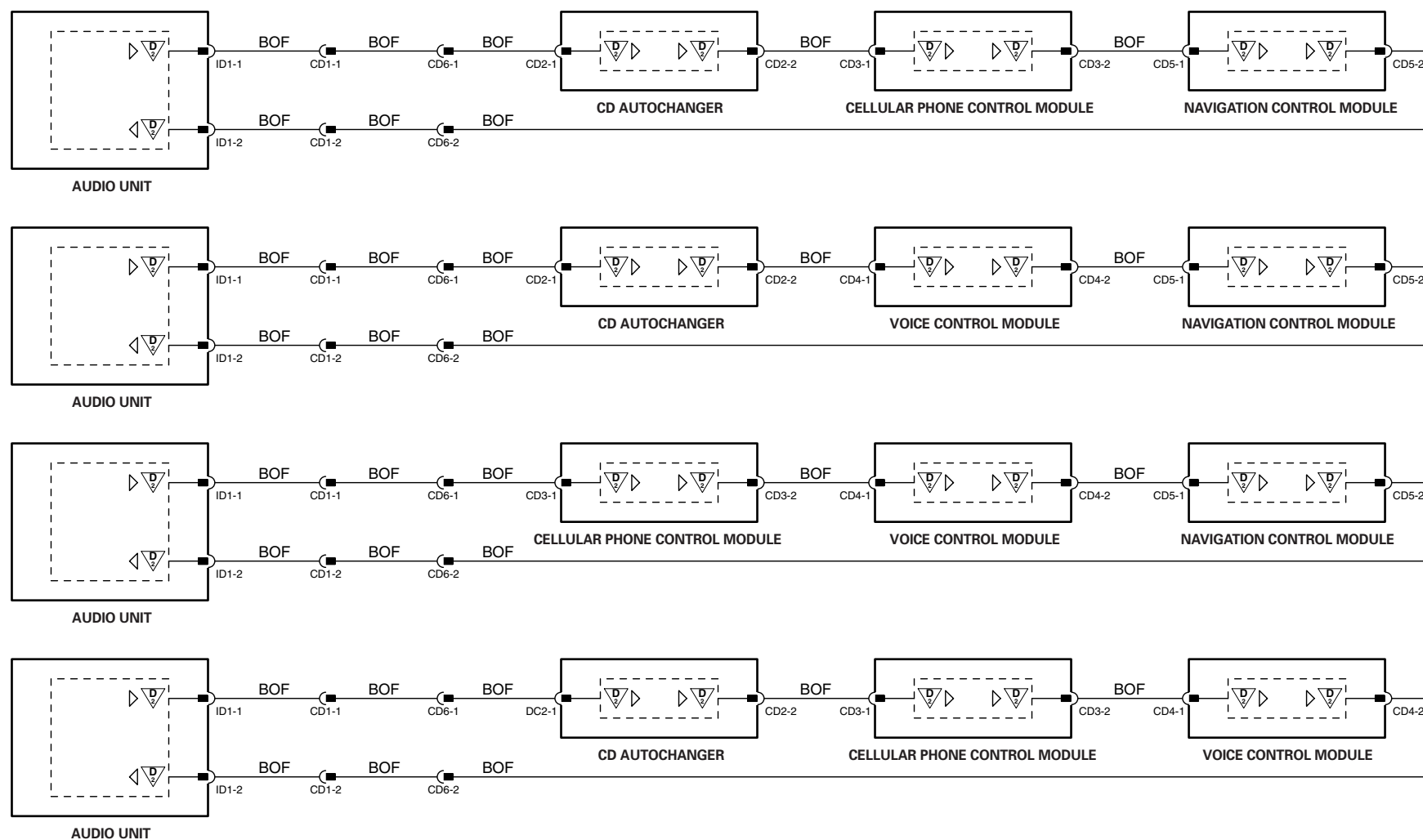

FOUR-MODULE NETWORKS

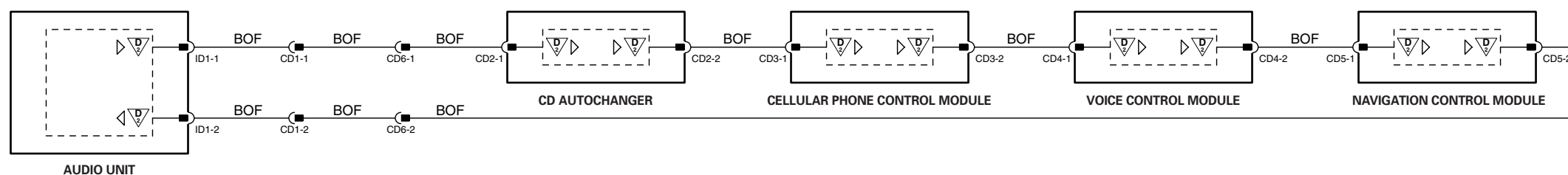

FIVE-MODULE NETWORK

NOTES:

Figs. 20.3 and 20.4 show all possible combinations of D2B Networks.
 Network "Wake-Up" Circuit – refer to Fig. 20.3.
 D2B Network Diagnostics – refer to Fig. 20.2.



This Appendix contains a listing of CAN and SCP Network messages.

The following acronyms and abbreviations are used throughout this section:

A/C	Air Conditioning
ABS	Anti Lock Braking System
ABSCM	Anti Lock Braking System Control Module
ABS/TCCM	Anti Lock Braking / Traction Control Control Module
A/CCM	Air Conditioning Control Module
ACK	Acknowledge
AIRCON	Climate Control
AT Cmd	Commands for configuring and controlling telecommunication devices
AUDIO	Audio Unit
BIT	Smallest element of data code (1 or 0)
BYTE	Grouping of 8 bits (one alphanumeric character)
°C	Degrees Centigrade
CAL	Calibrate
CAN	Controller Area Network
CID	CAN Identifier
CM	Control Module
CONFIG	Configure
D2B OPC	Instructions for translating and routing data for D2B use
D2B	Fibre Optic Network
DIAG	Diagnostics
DSCCM	Dynamic Stability Control Control Module
DTC	Diagnostic Trouble Code
ECM	Engine Control Module
°F	Degrees Fahrenheit
FL	Front Left
FR	Front Right
Gateway	Device that converts messages between different types of networks
GECM	General Electronic Control Module
HLCM	Headlight Levelling Control Module
IC	Instrument Cluster
IDB	Identification Byte
JGM	J Gate Module
Lb. Ft.	Pound Feet (Measure of Torque)
LED	Light Emitting Diode
m	Meter (length)
MIL	Malfunction Indicator Lamp
ml	Millilitre
ms	Millisecond
MSG	Message
NCM	Navigation Control Module
Nm	Newton Meter (Measure of Torque)
OBD	On Board Diagnostics
OBD II	On Board Diagnostics II
ODO	Odometer
Oz	Ounce
PATS	Passive Anti Theft System
PECUS	Programmable Electronic Control Units System
POS	Positive (+)
PTT	Push to Talk
RCC	Climate Control
RL	Rear Left
RPM	Revolutions Per Minute
RR	Rear Right
SCP	Standard Corporate Protocol Network
SMS	Short Message Service for Mobile Communications
STM	Switch to Test Mode
SWS	Steering Wheel Angle Sensor
TCM	Transmission Control Module
VEMS	JaguarNet
WDS	World Diagnostic System
YRS	Yaw Rate Sensor



SCP Message Matrix

No.	Message Name	Source	Receivers			
			GECM	IC	NCM	AUDIO
1	All headlamp status: OFF	IC	X			X
2	All headlamp status: ON	IC	X			X
3	All park lamp status: OFF	IC	X		X	X
4	All park lamp status: ON	IC	X		X	X
5	All turn lamp Command: OFF	GECM		X		
6	All turn lamp Command: ON	GECM		X		
7	Cellular phone in use: NO (False)	AUDIO		X		
8	Cellular phone in use: YES (True)	AUDIO		X		
9	Trunk lid ajar switch: ACTIVE	GECM		X		X
10	Trunk lid ajar switch: INACTIVE	GECM		X		X
11	Display access confirmation status: ACCEPT	IC			X	X
12	Display access confirmation status: REJECT	IC			X	X
13	Display access display string: Clear Display	AUDIO		X		
14	Display access display string: Clear Display	NCM		X		
15	Display access display string: Overwrite Display	AUDIO		X		
16	Display access display string: Overwrite Display	NCM		X		
17	Display access terminate command	AUDIO		X		
18	Display access terminate command	NCM		X		
19	Download block to display command	AUDIO		X		
20	Download block to display command	NCM		X		
21	Driver's front door ajar switch status: ACTIVE	GECM		X		X
22	Driver's front door ajar switch status: INACTIVE	GECM		X		X
23	Driver's rear door ajar switch status: ACTIVE	GECM		X		X
24	Driver's rear door ajar switch status: INACTIVE	GECM		X		X
25	Gateway A/CCM to Display	IC			X	
26	Gateway A/CCM to Voice	IC				X
27	Gateway Audio to NCM	AUDIO			X	
28	Gateway Audio to NCM (Multiframe)	AUDIO			X	
29	Gateway Display to A/CCM command	NCM		X		
30	Gateway NCM to Audio	NCM				X
31	Gateway NCM to Phone: AT Cmd frame 1	NCM				X



SCP Message Matrix

No.	Message Name	Source	Receivers			
			GECM	IC	NCM	AUDIO
32	Gateway NCM to Phone: AT Cmd frame 2	NCM				X
33	Gateway NCM to Phone: D2B OPC frame 1	NCM				X
34	Gateway NCM to Phone: D2B OPC frame 2	NCM				X
35	Gateway NCM to SMS: SMS Data frame 1	NCM				X
36	Gateway NCM to SMS: SMS Data frame 2	NCM				X
37	Gateway NCM to VEMS: AT Cmd frame 1	NCM				X
38	Gateway NCM to VEMS: AT Cmd frame 2	NCM				X
39	Gateway NCM to VEMS: D2B OPC frame 1	NCM				X
40	Gateway NCM to VEMS: D2B OPC frame 2	NCM				X
41	Gateway NCM to Voice	NCM				X
42	Gateway Phone to NCM: AT Cmd frame 1	AUDIO			X	
43	Gateway Phone to NCM: AT Cmd frame 2	AUDIO			X	
44	Gateway Phone to NCM: D2B OPC frame 1	AUDIO			X	
45	Gateway Phone to NCM: D2B OPC frame 2	AUDIO			X	
46	Gateway SMS to NCM: SMS Data frame 1	AUDIO			X	
47	Gateway SMS to NCM: SMS Data frame 2	AUDIO			X	
48	Gateway VEMS to NCM: AT Cmd frame 1	AUDIO			X	
49	Gateway VEMS to NCM: AT Cmd frame 2	AUDIO			X	
50	Gateway VEMS to NCM: D2B OPC frame 1	AUDIO			X	
51	Gateway VEMS to NCM: D2B OPC frame 2	AUDIO			X	
52	Gateway voice to A/CCM command	AUDIO		X		
53	Gateway voice to NCM	AUDIO			X	
54	Hood ajar switch: ACTIVE	GECM		X		X
55	Hood ajar switch: INACTIVE	GECM		X		X
56	Ignition switch position w / initialize status: NO	IC	X			X
57	Ignition switch position w / initialize status: YES	IC	X			X
58	Left side turn signal Command: OFF	GECM		X		
59	Left side turn signal Command: ON	GECM		X		
60	Low fuel level status: NO	IC				X
61	Low fuel level status: YES	IC				X
62	Low washer fluid warning: OFF	IC	X			



SCP Message Matrix

No.	Message Name	Source	Receivers			
			GECM	IC	NCM	AUDIO
63	Low washer fluid warning: ON	IC	X			
64	Network bus wake up Command: YES (True)	GECM				
65	Network bus wake up Command: YES (True)	IC				
66	Odometer rolling count status	IC			X	
67	Parking brake switch status: ACTIVE	IC				X
68	Parking brake switch status: INACTIVE	IC				X
69	Passenger's front door ajar switch status: ACTIVE	GECM		X		X
70	Passenger's front door ajar switch status: INACTIVE	GECM		X		X
71	Passenger's rear door ajar switch status: ACTIVE	GECM		X		X
72	Passenger's rear door ajar switch status: INACTIVE	GECM		X		X
73	Remote control button status: Button 7 (PTT) ACTIVE	AUDIO			X	
74	Remote control button status: Button 6 (VOL+) ACTIVE	AUDIO			X	
75	Remote control button status: Button 5 (VOL) ACTIVE	AUDIO			X	
76	Remote control button status: Button 4 (Select) ACTIVE	AUDIO			X	
77	Remote control button status: Button 3 (Seek UP) ACTIVE	AUDIO			X	
78	Remote control button status: Button 2 (Seek DOWN) ACTIVE	AUDIO			X	
79	Remote control button status: All buttons INACTIVE	AUDIO			X	
80	Request all headlamp status	GECM		X		
81	Request all headlamp status	AUDIO		X		
82	Request all park lamp status	GECM		X		
83	Request all park lamp status	NCM		X		
84	Request all park lamp status	AUDIO		X		
85	Request trunk ajar switch status	IC	X			
86	Request trunk ajar switch status	AUDIO	X			
87	Request driver's front door ajar switch status	IC	X			
88	Request driver's front door ajar switch status	AUDIO	X			
89	Request driver's rear door ajar switch status	IC	X			
90	Request driver's rear door ajar switch status	AUDIO	X			
91	Request hood ajar switch status	IC	X			
92	Request hood ajar switch status	AUDIO	X			
93	Request ignition switch position w / Initialize status	GECM		X		



SCP Message Matrix

No.	Message Name	Source	Receivers			
			GECM	IC	NCM	AUDIO
94	Request ignition switch position w / initialize status	AUDIO		X		
95	Request ignition switch position w / initialize status	NCM		X		
96	Request low fuel level status	NCM		X		
97	Request low washer fluid warning command	GECM		X		
98	Request parking brake switch status	AUDIO		X		
99	Request passenger's front door ajar switch status	IC	X			
100	Request passenger's front door ajar switch status	AUDIO	X			
101	Request passenger's rear door ajar switch status	IC	X			
102	Request passenger's rear door ajar switch status	AUDIO	X			
103	Request seat belt warning status	IC	X			
104	Request vehicle Security System status	IC	X			
105	Request vehicle configuration module programmed status	IC	X			
106	Request vehicle Inertia Switch status	GECM		X		
107	Request vehicle Security key status	GECM		X		
108	Request vehicle Security key status	AUDIO		X		
109	Right side turn signal turn lamp Command: OFF	GECM		X		
110	Right side turn signal turn lamp Command: ON	GECM		X		
111	Seat belt warning Command: OFF	GECM		X		
112	Seat belt warning Command: ON	GECM		X		
113	Terminate display confirmation status: ACCEPT	IC			X	X
114	Terminate display confirmation status: REJECT	IC			X	X
115	Terminate display definition command	AUDIO		X		
116	Terminate display definition command	NCM		X		
117	Time of day (w / mode) command	NCM				X
118	Time of day (w / mode) status	AUDIO			X	
119	Transit mode Command: ACTIVE	EXTERN	X	X		
120	Transit mode Command: INACTIVE	IC	X			
121	Transmission PRNDL range selected status	IC				X
122	Vehicle Security System status	GECM		X		
123	Vehicle configuration module programmed status: NO	GECM		X		
124	Vehicle configuration module programmed status: NO	AUDIO		X		



SCP Message Matrix

No.	Message Name	Source	Receivers			
			GECM	IC	NCM	AUDIO
125	Vehicle configuration module programmed status: YES	GECM		X		
126	Vehicle Inertia Switch status: ACTIVE (Crashed)	IC	X			
127	Vehicle Inertia Switch status: INACTIVE (OK)	IC	X			
128	Vehicle Security key status	IC	X			X
129	Vehicle speed high resolution status	IC	X			X
130	VACM control mode status: OFF	AUDIO	X	X		
131	VACM control mode status: ON	AUDIO	X	X		
132	VACM control mode status: OFF	NCM	X	X		
133	VACM control mode status: ON	NCM	X	X		
134	VACM training mode A/B entry	NCM				X



CAN Message Matrix

No.	Message Name	Usage	Source	Receivers													
				ABSCM	ABS/TCCM	DSCCM	ECM	TCM	IC	A/CCM	HLCM	JGM	SWS	YRS	DIAG		
097h	CAN INDICATED ENGINE TORQUE	Estimated available torque: current engine speed, load, ignition timing and fuelling intervention not included	ECM	X	X	X	X	X	X								
097h	CAN ENGINE FRICTION TORQUE	Estimated torque loss caused by: engine friction, engine driven accessories	ECM	X	X	X	X	X	X								
097h	CAN ACTUAL ENGINE TORQUE	Estimated available torque: current engine speed, load ignition timing and fuelling	ECM	X	X	X	X	X	X								
097h	CAN DRIVER DEMAND TORQUE	Estimated available torque: current throttle pedal position, no intervention included	ECM	X	X	X	X	X	X								
0C9h	CAN TORQUE REDUCTION REQUEST	Torque reduction requested for shift energy management (uses ignition intervention only)	TCM				X										
0C9h	CAN TRANSMISSION TORQUE LIMIT	Engine torque limit with current transmission fault	TCM				X										
0C9h	CAN TORQUE CONVERTER SLIP	Percentage of torque converter slip	TCM	X	X	X	X	X	X								
0C9h	CAN TRANSMISSION INPUT SPEED	Transmission input shaft RPM	TCM				X										
0C9h	CAN TRANSMISSION OUTPUT SPEED	Transmission output shaft RPM	TCM				X										
0FBh	CAN TRACTION SHIFT MAP	Use Traction Shift Map	ABSCM						X								
0FBh	CAN TRACTION SHIFT MAP	Use Traction Shift Map	ABS/TCCM						X								
0FBh	CAN TRACTION SHIFT MAP	Use Traction Shift Map	DSCCM						X								
0FBh	CAN OBD II ABS CLEAR ACK	Confirms ABS OBD II DTCs cleared	ABSCM				X										
0FBh	CAN OBD II ABS CLEAR ACK	Confirms ABS OBD II DTCs cleared	ABS/TCCM				X										
0FBh	CAN OBD II ABS CLEAR ACK	Confirms DSC OBD II DTCs cleared	DSCCM				X										
0FBh	CAN ABS FAULT CODE MIL STATUS	Indicates flagged DTC requires MIL illumination	ABSCM				X										
0FBh	CAN ABS FAULT CODE MIL STATUS	Indicates flagged DTC requires MIL illumination	ABS/TCCM				X										
0FBh	CAN ABS FAULT CODE MIL STATUS	Indicates flagged DTC requires MIL illumination	DSCCM				X										
0FBh	CAN ABS STATUS	Indicates when ABS system is functioning	ABSCM														
0FBh	CAN ABS STATUS	Indicates when ABS system is functioning	ABS/TCCM														
0FBh	CAN ABS STATUS	Indicates when ABS system is functioning	DSCCM														
0FBh	CAN VEHICLE REFERENCE SPEED	Vehicle speed (reference wheel circumference X wheel rotation speed)	ABSCM				X	X	X	X							
0FBh	CAN VEHICLE REFERENCE SPEED	Vehicle speed (reference wheel circumference X wheel rotation speed)	ABS/TCCM				X	X	X	X							
0FBh	CAN VEHICLE REFERENCE SPEED	Vehicle speed (reference wheel circumference X wheel rotation speed)	DSCCM				X	X	X	X							
0FBh	CAN ABS FAULT CODES	Indicates ABS DTCs to store in the ECM	ABSCM				X										
0FBh	CAN ABS FAULT CODES	Indicates ABS DTCs to store in the ECM	ABS/TCCM				X										
0FBh	CAN ABS FAULT CODES	Indicates ABS DTCs to store in the ECM	DSCCM				X										



CAN Message Matrix

No.	Message Name	Usage	Source	Receivers													
				ABSCM	ABS/TCCM	DSCCM	ECM	TCM	IC	A/CCM	HLCM	JGM	SWS	YRS	DIAG		
0FBh	CAN ODO ROLLING COUNT	Rolling count of distance vehicle has travelled	ABSCM							X							
0FBh	CAN ODO ROLLING COUNT	Rolling count of distance vehicle has travelled	ABS/TCCM							X							
0FBh	CAN ODO ROLLING COUNT	Rolling count of distance vehicle has travelled	DSCCM								X						
0FBh	CAN ABS MALFUNCTION	ABS and brakes malfunction data, also activates IC warnings	ABSCM						X								
0FBh	CAN ABS MALFUNCTION	ABS/TC and brakes malfunction data, also activates IC warnings	ABS/TCCM						X								
0FBh	CAN ABS MALFUNCTION	ABS, DSC and brakes malfunction data, also activates IC warnings	DSCCM						X								
0FBh	CAN ABS FLAGS	ABS and brake systems status and flag information	ABSCM						X	X							
0FBh	CAN ABS FLAGS	ABS/TC and brake systems status and flag information	ABS/TCCM						X	X							
0FBh	CAN ABS FLAGS	ABS, DSC and brake systems status and flag information	DSCCM						X	X							
120h	CAN TRANS INPUT INDICATED TORQUE	Engine torque input to transmission, includes interventions	ECM	X	X						X						
12Dh	CAN ENGINE ACCELERATION	Rate of engine speed increase	ECM	X	X												
12Dh	CAN THROTTLE POSITION	Target throttle valve position	ECM	X	X						X						
12Dh	CAN PEDAL POSITION	Accelerator pedal position, driver throttle demand	ECM	X	X						X						
12Dh	CAN ENGINE SPEED	Engine speed in RPM	ECM	X	X						X	X					
12Dh	CAN ALTERNATOR STATUS	Alternator status: fault or OK	ECM									X					
12Dh	CAN CRUISE STATUS	Cruise control status: Override switch active, Cruise ON, enabled, resuming	ECM									X					
12Dh	CAN OBD II CLEAR FAULT CODES	Request ABS and TCM to clear OBD DTCs	ECM	X	X						X						
12Dh	CAN BRAKE PEDAL PRESSED	Brake switch status	ECM								X		X				
12Dh	CAN CRANK IN PROGRESS	Engine cranking in progress	ECM	X	X						X	X					
12Dh	CAN TRACTION ACKNOWLEDGE	Confirms torque reduction in progress, can / cannot achieve, unable to respond	ECM	X	X												
12Dh	CAN FUEL CAP WARNING	Display Check Fuel Cap warning	ECM									X					
1F5h	CAN BRAKE FLUID LOW	Display Brake Fluid Level Low	IC	X	X												
1F5h	CAN PARK BRAKE STATUS	Parking brake: OFF / ON	IC	X	X								X				
1F5h	CAN DIPPED BEAM STATUS	Headlight dipped beam: OFF / ON	IC											X			
1F5h	CAN REV GEAR MAN SELECTED	Manual transmission only, reverse gear selected	IC														
1F5h	CAN OIL PRESSURE LOW	Engine oil pressure below specification	IC														
1F5h	CAN RESTRICT RCC BLOWERS	Restrict climate control blower speed	IC														X
1F5h	CAN FUEL LEVEL DAMPED	Damped fuel level (fuel gauge signal)	IC														X



CAN Message Matrix

No.	Message Name	Usage	Source	Receivers													
				ABSCM	ABS/TCCM	DSCCM	ECM	TCM	IC	A/CCM	HLCM	JGM	SWS	YRS	DIAG		
1F5h	CAN FUEL LEVEL RAW 1	Fuel level sender 1 signal (before signal conditioning)	IC				X										
1F5h	CAN FUEL LEVEL RAW 2	Fuel level sender 2 signal (before signal conditioning)	IC				X										
3E9h	CAN GEAR POSITION ACTUAL	Transmission gear positions: N, 1, 2, 3, 4, 5, R, or shift in progress	TCM	X	X		X										
3E9h	CAN GEAR POSITION SELECTED	Transmission rotary switch positions: P, R N, D, 4, 3, 2, or selector between positions signals	TCM				X							X			
3E9h	CAN TRANSMISSION SHIFT MAP	TCM shift map in use signal: Normal, Sport, Hot, Gradient, Traction, Manual, or Cruise	TCM	X	X		X										
3E9h	CAN TRANSMISSION OIL TEMPERATURE	Transmission fluid temperature -40 °C to 214 °C. Note: will not exceed 150 °C	TCM				X										
3E9h	CAN TRANSMISSION MALFUNCTION	Transmission malfunction data, also activate transmission warning signals	TCM	X	X		X										
3E9h	CAN TCM CONFIG FLAG	TCM PECUS programmed YES / NO	TCM							X							
3E9h	CAN TORQUE CONVERTER STATUS	Torque converter clutch disengaged, engaged or constant slip	TCM	X	X		X										
3E9h	CAN GEAR SELECTION FAULT	CAN GEAR POSITION SELECTED signal validity	TCM				X							X			
3E9h	CAN IDLE NEUTRAL CONTROL	Idle neutral control in / not in progress	TCM				X										
3E9h	CAN PERFORMANCE MODE INDICATION	Switch Performance Mode LED ON / OFF	TCM											X			
3E9h	CAN TCM FAULT CODE MIL STATUS	Indicates flagged DTC requires MIL illumination	TCM				X										
3E9h	CAN OBD II TCM CLEAR ACK	Confirms transmission OBD DTCs cleared	TCM				X										
3E9h	CAN TRANSMISSION FAULT CODES	Indicates transmission fault codes to store ECM	TCM	X	X		X										
3E9h	CAN GEAR POSITION TARGET	Next actual transmission gear position (for traction control)	TCM	X	X		X										
41Ah	CAN PRESSURE TRANSDUCER	A/C refrigerant pressure, for fan control and diagnostics	TCM							X							
41Ah	CAN ENGINE INTAKE TEMPERATURE	Engine intake air temperature: 40 °C to 80 °C (40 °F to 176 °F)	ECM							X							
41Ah	CAN A/C CLUTCH INHIBIT STATUS	Confirms A/C compressor clutch ON / OFF	ECM							X							
41Ah	CAN ELECTRICAL LOAD MANAGEMENT	Inhibit: heated rear window, windshield, wiper park area, automatic heated windshield.	ECM							X							
41Ah	CAN COOLING FAN FEEDBACK	Actual cooling fan speed. Response to COOLING FAN REQUEST message	ECM											X			
441h	CAN AMBIENT TEMPERATURE	Outside air temperature 40 °C to 80 °C (40 °F to 176 °F)	A/CCM				X										
441h	CAN COMPRESSOR TORQUE	Predicted A/C compressor torque in 100 ms	A/CCM				X										
441h	CAN A/C COMMANDS	Request A/C compressor ON / OFF. Maximum heat required: YES / NO	A/CCM				X										
441h	CAN A/C STATUS	Indicates: windshield, rear door mirrors, and windshield wiper park area heater ON / OFF and blower speed	A/CCM				X										



CAN Message Matrix

No.	Message Name	Usage	Source	Receivers													
				ABSCM	ABS/TCCM	DSCCM	ECM	TCM	IC	A/CCM	HLCM	JGM	SWS	YRS	DIAG		
697h	CAN AIRCON DISPLAY STATUS	CAN to SCP gateway message	A/CCM								X						
6A0h	CAN POWERTRAIN CONFIGURATION	Network management	ECM					X									
6F1h	CAN SWS COMMAND CODE WORD	Steering Angle Sensor calibration instructions	DSCCM											X			
6F1h	CAN SWS CID	CAN Identifier for message transmission	DSCCM											X			
7C4h	CAN DIAGNOSTIC DATA IN RCC	A/CCM diagnostics message	DIAG									X					
7C5h	CAN DIAGNOSTIC DATA OUT RCC	A/CCM diagnostics data out. Only in response to message #7C4h	A/CCM														X
7E8h	CAN DIAGNOSTIC DATA IN ECM	ECM diagnostics message	DIAG						X								
7E9h	CAN DIAGNOSTIC DATA IN TCM	TCM diagnostics message	DIAG							X							
7Eah	CAN DIAGNOSTIC DATA IN IC	IC diagnostics message	DIAG								X						
7Ebh	CAN DIAGNOSTIC DATA IN ABS	ABSCM diagnostics message	DIAG						X								
7Ech	CAN DIAGNOSTIC DATA OUT ECM	ECM diagnostics data out. Only in response to message #7E8h	ECM														X
7Edh	CAN DIAGNOSTIC DATA OUT TCM	TCM diagnostics data out. Only in response to message #7E9h	TCM														X
7Eeh	CAN DIAGNOSTIC DATA OUT IC	IC diagnostics data out. Only in response to message #7EAh	IC														X
7Efh	CAN DIAGNOSTIC DATA OUT ABS	ABSCM diagnostics data out. Only in response to message #7EBh	ABSCM														X
7Efh	CAN DIAGNOSTIC DATA OUT ABS	ABSCM diagnostics data out. Only in response to message #7EBh	ABS/TCCM														X
7Efh	CAN DIAGNOSTIC DATA OUT ABS	DSCCM diagnostics data out. Only in response to message #7EBh	DSCCM														X